



Office of the City Manager

SUPPLEMENTAL AGENDA MATERIAL for Supplemental Packet 1

Meeting Date: September 28, 2021

Item Number: 32

Item Description: Adoption of the Baseline Zoning Ordinance (BZO)

Submitted by: Jordan Klein, Director, Planning and Development Department

In response to Councilmember comments and feedback received after the September 14, 2021 agenda materials were published, the following modifications are presented for Council consideration. The modifications are presented in four categories:

1. Modifications to select consent changes
2. Modifications in response to Supplemental 2, submitted September 13, 2021
3. Modifications in response to City Council deliberations on September 14, 2021
4. Technical edits

Modifications to Select Consent Changes

1. BZO Section 23.102.070 – Conflicting Provisions (pg. 15)

Original BZO Language

23.102.070 – Conflicting Provisions

- A. **Conflict with State or Federal Regulations.** Where the Zoning Ordinance conflicts with state or federal laws, higher law controls over lower law unless local variation is permitted.
- B. **Conflict with Other City Regulations.** Where the Zoning Ordinance conflicts with other ordinances, resolutions, or regulations of the City of Berkeley, the more restrictive controls.

- C. **Conflict with Private Agreements.** It is not the intent of the Zoning Ordinance to interfere with, abrogate, or annul any easement, covenant, deed restriction, or other agreement between private parties. If the Zoning Ordinance imposes a greater restriction than imposed by a private agreement, the Zoning Ordinance controls. Private agreements may impose greater restrictions than the Zoning Ordinance, but the City is not responsible for monitoring or enforcing private agreements.

Proposed Modification to BZO Language

23.107.070— ~~Conflicting Provisions Conflict with Private Agreements~~

~~A. **Conflict with State or Federal Regulations.** Where the Zoning Ordinance conflicts with state or federal laws, higher law controls over lower law unless local variation is permitted.~~

~~B. **Conflict with Other City Regulations.** Where the Zoning Ordinance conflicts with other ordinances, resolutions, or regulations of the City of Berkeley, the more restrictive controls.~~

A. Conflict with Private Agreements. It is not the intent of the Zoning Ordinance to interfere with, abrogate, or annul any easement, covenant, deed restriction, or other agreement between private parties. If the Zoning Ordinance imposes a greater restriction than imposed by a private agreement, the Zoning Ordinance controls. Private agreements may impose greater restrictions than the Zoning Ordinance, ~~but the City is not responsible for~~ and at its sole discretion, the City may ~~monitoring or enforcing~~ private agreements.

Rationale:

The language in Sections A and B is unnecessary and may lead to confusion, so it has been deleted.

With the deletion of Sections A and B, Section C is the only one that remains. New language was added to this section to clarify that the City, while at no obligation to do so, may monitor and enforce private agreements if it so chooses.

2. BZO Section 23.404.050.A – Public Hearings and Decisions (pg. 383)

Original BZO Language

A. General. Hearings shall be conducted in a manner consistent with the procedures approved by the review authority.

Proposed Modification to BZO Language

A. General. Hearings shall be conducted in a manner consistent with the requirements of State and local law and the procedures approved by the review authority.

Rationale: This added language clarifies that there are additional requirements on the conduct of public hearings beyond what a review authority may approve.

3. BZO Section 23.412.050.C City Council (pg. 425)

Original BZO Language

C. Effective Date. Zoning Ordinance Amendments become effective 30 days after the adoption of the ordinance by the City Council.

Proposed Modification to BZO Language

C. Effective Date. Zoning Ordinance Amendments become effective 30 days after the adoption of the ordinance by the City Council, or at a date determined by the City Council.

Rationale: This change permits the City Council to determine an effective date for an Ordinance other than 30 days.

Modifications in Response to Supplemental 2

4. BZO Section 23.104.020 – Zoning Officer -- Authority (pg. 17)

Original BZO Language

The Zoning Officer is responsible for interpreting the meaning and applicability of all provisions in the Zoning Ordinance. Zoning Officer interpretations are subject to review and modification by the Zoning Adjustments Board (ZAB) and City Council.

Proposed Modification to BZO Language

The Zoning Officer ~~is responsible for interpreting~~ has the authority to interpret the meaning and applicability of ~~all provisions in~~ the Zoning Ordinance. Zoning Officer interpretations are subject to review and modification by the Zoning Adjustments Board (ZAB) and City Council.

Rationale: The section is amended to clarify that the Zoning Officer has the authority to interpret the BZO, but is not the ultimate interpreter of the BZO in all cases.

5. BZO Section 23.402.040 – Zoning Officer (pg. 368)

Original BZO Language

A. Responsibilities and Powers.

1. The Zoning Officer:

- a. Acts as the Secretary to the Zoning Adjustments Board (ZAB) and the Design Review Committee (DRC);
- b. Determines if land uses, structures, and activities conform with the Zoning Ordinance;
- c. Serves as the review authority on applications as shown in Table 23.402-1: Review and Decision-Making Authority;
- d. Interprets the meaning and applicability of the Zoning Ordinance...

Proposed Modification to BZO Language

A. Responsibilities and ~~Powers~~ Duties.

1. The Zoning Officer:

- a. Acts as the Secretary to the Zoning Adjustments Board (ZAB) and the Design Review Committee (DRC);
- b. Determines if land uses, structures, and activities conform with the Zoning Ordinance;
- c. Serves as the review authority on applications as shown in Table 23.402-1: Review and Decision-Making Authority;
- d. Has the authority to interprets the meaning and applicability of the Zoning Ordinance...
- e. ...

Rationale: This language is changed to better mirror the language in the existing Zoning Ordinance and to maintain consistency with BZO 23.104.020 (Zoning Officer- Authority; see 4, above).

6. BZO Section 23.402.040.B.1.i – Zoning Officer (pg. 369)

Original BZO Language

- i. Performs other duties to administer the Zoning Ordinance as assigned by the ZAB, Planning Commission, and City Council.

Proposed Modification to BZO Language

- i. Performs other duties to administer the Zoning Ordinance as assigned by the ~~ZAB, Planning Commission, and~~ City Council.

Rationale: This language is changed to clarify that it is only the City Administrator and City Council that can assign duties to the Zoning Officer.

Modifications in Response to City Council Deliberation

7. BZO Section 23.210.020 – Hillside Overlay Zone (pg. 193)

Proposed Modification to BZO Language

2. Protect the safety and health of residents where steep topography, unusual street conditions and proximity to the wildland-urban interface create severe risk from wildfire.

Rationale: This language, proposed by Councilmember Wengraf, is added to codify existing practice regarding why special land use regulations are appropriate in the H overlay zone.

Technical Edits

8. Table 23.402 – Review and Decision-Making Authority (pg. 366)

Proposed Modification to BZO Language

A column for the Landmarks Preservation Commission was added to this table.

Rationale: In the original BZO table, the role of the LPC in Design Review was included as a footnote to the Design Review Committee. This change adds the LPC to the table itself for greater clarity.

9. BZO Section 23.402.050 – Landmarks Preservation Commission (pg. 369)

Original BZO Language

1. **Design Review.** The Landmarks Preservation Commission (LPC) shall consider Design Review applications for projects that involve landmarks, structures of merit, or buildings within a historic district. The LPC shall either approve, modify, or deny such applications in accordance with Section 23.406.070– Design Review.
2. **Other Responsibilities and Powers.**
 - a. As provided in Municipal Code Chapter 3.24 (Landmarks Preservation Commission), the LPC shall serve as the review authority for Structural Alteration Permits for designated landmarks, structures of merit, and buildings within a historic district.
 - b. Municipal Code Chapter 3.24 identifies additional LPC responsibilities and powers which may affect land use and development in the city.

Proposed Modification to BZO Language

~~**Design Review.** The Landmarks Preservation Commission (LPC) shall consider Design Review applications for projects that involve landmarks, structures of merit, or buildings within a historic district. The LPC shall either approve, modify, or deny such applications in accordance with Section 23.406.070– Design Review.~~

1. ~~Other~~ **Responsibilities and Powers.**

~~As provided in Municipal Code Chapter 3.24 (Landmarks Preservation Commission), the LPC shall serve as the review authority for Structural Alteration Permits for designated landmarks, structures of merit, and buildings within a historic district.~~

- a. Municipal Code Chapter 3.24 identifies ~~additional LPC~~ the responsibilities and powers ~~of the Landmarks Preservation Commission which may affect land use and development in the city.~~

- b. **Design Review.** The Landmarks Preservation Commission (LPC) shall consider Design Review applications for projects that involve landmarks, structures of merit, or buildings within a historic district. The LPC shall either approve, modify, or deny such applications in accordance with Section 23.406.070– Design Review.

Rationale: Consistent with the BZO Style Guide, this language change makes the most important aspect of the LPC—its wide-ranging responsibilities as detailed in Chapter 3.24—the first and most prominent fact in the BZO. Its role in one distinct area of responsibility, Design Review, is then detailed afterwards.

10. BZO Section 23.402.060.C – Landmarks Preservation Commission (pg. 370)

Original BZO Language

2. The DRC may make a recommendation on other matters upon request by the ZAB, Planning Commission, City Council, or other City boards or commissions. ZAB recommendations shall be limited to issues related to building and site design.

Proposed Modification to BZO Language

2. The DRC may make a recommendation on other matters upon request by the ZAB, Planning Commission, City Council, or other City boards or commissions. ~~ZAB DRC~~ recommendations shall be limited to the subject areas of its expertise ~~issues related to building and site design.~~

Rationale: The first change—from ZAB to DRC—is a copy edit. The second change is recommended because the original BZO language may inadvertently limit the range of what the DRC may address. The language is changed to better mirror the DRC’s responsibilities as stated in [BMC 23B.08.020.D](#) [**emphasis added**].

Upon request, the [Design Review] Committee may make a recommendation on matters brought to its attention by the Board, the Planning Commission, the Council or any other City Board or Commission. Such recommendations shall be limited to ***the subject areas of its expertise.***

11. BZO Section 23.402.070.C.1.c – Zoning Adjustments Board (pg. 371)

Original BZO Language

2. Modifies previously approved permits in accordance with Section 23.404.070– Permit Modifications;

Proposed Modification to BZO Language

2. Modifies previously approved Use Ppermits and Variances in accordance with Section 23.404.070– Permit Modifications;

Rationale: This added language makes explicit that both Use Permit and Variance modifications are responsibilities of the ZAB.

12. BZO Section 23.402.070.C.1.e – Zoning Adjustments Board (pg. 371)

Original BZO Language

- e. Recommends actions to abate a public nuisance in accordance with Chapter 23.414—Nuisance Abatement;

Proposed Modification to BZO Language

- e. Recommends actions to **enforce the zoning ordinance, including to** abate a public nuisance in accordance with Chapter 23.414—Nuisance Abatement;

Rationale: The ZAB does not just make recommendations on how to abate a public nuisance, but has formal authority to enforce Nuisance Abatement provisions.

13. BZO Section 23.402.070.C.1.g – Zoning Adjustments Board (pg. 371)

Original BZO Language

- g. Makes recommendations on other matters as requested by the City Council and Planning Commission; and

Proposed Modification to BZO Language

- g. Makes recommendations on other matters as requested by the City Council, **and** Planning Commission, **or any other City Board or Commission**; and

Rationale: This added language better reflects the language in [BMC 23B.04.020.B.6](#) [**emphasis added**]:

- 6. Upon request, make recommendations on other matters brought to its attention by the Council, the Planning Commission **or any other City Board or Commission**; and

14. BZO Section 23.306.020 – Accessory Dwelling Units (pg. 243)

Original BZO Language

- A. The provisions of this chapter apply to all lots with at least one existing or proposed dwelling unit.

Proposed Modification to BZO Language

- A. The provisions of this chapter apply to all lots with at least **one** existing or proposed dwelling unit.

Rationale: Copy edit.

15. BZO Section 23.406.030.H.1 – Administrative Use Permits (pg. 395)

Original BZO Language

H. Findings of Approval

1. To approve an AUP, the Zoning Officer shall find that the proposed project:

Proposed Modification to BZO Language

H. Findings of Approval

1. To approve an AUP, the Zoning Officer shall find that the proposed project or use:

Rationale: This added language clarifies that both projects and uses are subject to findings. This reflects language included in [BMC 23B.28.050.A](#) that is broader than “project” [**emphasis added**]

A. The Zoning Officer may issue an AUP, either as submitted or as modified, only upon finding that ***the establishment, maintenance or operation of the use, or the construction of a building, structure or addition*** thereto...

16. BZO Section 23.406.040.E.1 Use Permits (pg. 396)

Original BZO Language

E. Findings of Approval

1. To approve a Use Permit, the Zoning Officer shall find that the proposed project:

Proposed Modification to BZO Language

E. Findings of Approval

1. To approve a Use Permit, the Zoning Officer shall find that the proposed project or use:

Rationale: Similar to 14, above, this added language clarifies that both projects and uses are subject to findings. This reflects language included in [BMC 23B.28.050.A](#) that is broader than “project” [**emphasis added**]

A. The Zoning Officer may issue an AUP, either as submitted or as modified, only upon finding that ***the establishment, maintenance or operation of the use, or the construction of a building, structure or addition*** thereto...

ORDINANCE NO. -N.S.

REPEALING ZONING ORDINANCE AND OFFICIAL ZONING MAP (BERKELEY MUNICIPAL CODE TITLE 23) AND ADOPTING NEW ZONING ORDINANCE AND OFFICIAL ZONING MAP

BE IT ORDAINED by the Council of the City of Berkeley as follows:

Section 1. That the existing Berkeley Municipal Code Title 23, including the Official Zoning Map adopted by Berkeley Municipal Code Section 23A.16.010, is repealed.

Section 2. That a new Berkeley Municipal Code Title 23 is adopted as set forth in Exhibit A.

Section 3. That the new Official Zoning Map is adopted as set forth in Exhibit B.

Section 4. That the new Official Zoning Map maintains existing boundaries, but creates two new zoning districts (University Avenue Commercial [C-U] and Corridor Commercial [C-C]) from the General Commercial (C-1) zoning district.

Section 5. That the effective date of this Ordinance is December 1, 2021 and that the City Clerk is directed to codify an online version of the Zoning Ordinance that includes necessary technical edits, graphics, hyperlinks, and grammatical corrections.

Section 6. Copies of this Ordinance shall be posted for two days prior to adoption in the display case located near the walkway in front of the Maudelle Shirek Building, 2134 Martin Luther King Jr. Way. Within 15 days of adoption, copies of this Ordinance shall be filed at each branch of the Berkeley Public Library and the title shall be published in a newspaper of general circulation.

Exhibits

A: New Baseline Zoning Ordinance (BMC Title 23)

B: New Official Zoning Map

TABLE OF CONTENTS

DIVISION 1 – GENERAL PROVISIONS

| | | |
|---------------|--|-----------|
| 23.102 | Introductory Provisions | 12 |
| 23.102.010 | – Title | 12 |
| 23.102.020 | – Effective Date..... | 12 |
| 23.102.030 | – Authority..... | 12 |
| 23.102.040 | – Purpose of the Zoning Ordinance | 12 |
| 23.102.050 | – Applicability and Jurisdiction | 13 |
| 23.102.060 | – Emergencies | 14 |
| 23.102.070 | – Conflicting Provisions Conflict with Private Agreements | 15 |
| 23.102.080 | – Transitional Provisions | 15 |
| 23.102.090 | – Severability | 16 |
| 23.102.100 | – Rules of Evidence and Procedure..... | 16 |
| 23.104 | Interpreting the Zoning Ordinance..... | 17 |
| 23.104.010 | – Chapter Purpose | 17 |
| 23.104.020 | – Authority..... | 17 |
| 23.104.030 | – Rules of Interpretation..... | 17 |
| 23.104.040 | – Threshold Regulations | 19 |
| 23.104.050 | – Zoning Map | 19 |
| 23.106 | Rules of Measurement | 20 |
| 23.106.010 | – Chapter Purpose | 20 |
| 23.106.020 | – Lot Coverage | 20 |
| 23.106.030 | – Floor Area, Gross..... | 20 |
| 23.106.040 | – Floor Area, Leasable..... | 21 |
| 23.106.050 | – Floor Area Ratio..... | 22 |
| 23.106.060 | – Story | 22 |
| 23.106.070 | – Setbacks | 23 |
| 23.106.080 | – Building Separation..... | 24 |
| 23.106.090 | – Height..... | 24 |

| | | |
|---------------|---------------------------------------|-----------|
| 23.108 | Zoning Districts and Map | 27 |
| 23.108.010 | – Chapter Purpose | 27 |
| 23.108.020 | – Zoning Districts | 27 |
| 23.108.030 | – Zoning Map | 29 |

DIVISION 2 -- ZONING DISTRICTS

| | | |
|---------------|--|-----------|
| 23.202 | Residential Districts | 32 |
| 23.202.010 | – Chapter Purpose | 32 |
| 23.202.020 | – Allowed Land Uses | 32 |
| 23.202.030 | – Additional Permit Requirements..... | 36 |
| 23.202.040 | – Use-Specific Regulations..... | 37 |
| 23.202.050 | – R-1 Single-Family Residential District..... | 37 |
| 23.202.060 | – R-1A Limited Two-Family Residential District | 39 |
| 23.202.070 | – ES-R Environmental Safety-Residential District..... | 41 |
| 23.202.080 | – R-2 Restricted Two-Family Residential District | 48 |
| 23.202.090 | – R-2A Restricted Multiple-Family Residential District | 50 |
| 23.202.100 | – R-3 Multiple-Family Residential District..... | 52 |
| 23.202.110 | – R-4 Multi-Family Residential District | 55 |
| 23.202.120 | – R-5 High-Density Residential District | 57 |
| 23.202.130 | – R-S Residential Southside District | 59 |
| 23.202.140 | – R-SMU Residential Southside District..... | 62 |
| 23.204 | Commercial Districts | 68 |
| 23.204.010 | – Chapter Purpose | 68 |
| 23.204.020 | – Allowed Land Uses | 68 |
| 23.204.030 | – Additional Permit Requirements..... | 80 |
| 23.204.040 | – Use-Specific Permit Requirements and Regulations | 83 |
| 23.204.050 | – C-C Corridor Commercial District..... | 86 |
| 23.204.060 | – C-U University Commercial District..... | 90 |
| 23.204.070 | – C-N Neighborhood Commercial District | 99 |
| 23.204.080 | – C-E Elmwood Commercial District | 103 |
| 23.204.090 | – C-NS North Shattuck Commercial District..... | 107 |
| 23.204.100 | – C-SA South Area Commercial District | 111 |

| | | |
|---------------|---|------------|
| 23.204.110 | – C-T Telegraph Avenue Commercial District..... | 119 |
| 23.204.120 | – C-SO Solano Avenue Commercial District..... | 124 |
| 23.204.130 | – C-DMU Downtown Mixed-Use District | 129 |
| 23.204.140 | – C-W West Berkeley Commercial District..... | 140 |
| 23.204.150 | – C-AC Adeline Corridor Commercial District | 147 |
| 23.206 | Manufacturing Districts | 159 |
| 23.206.010 | – Chapter Purpose | 159 |
| 23.206.020 | – Allowed Land Uses and Permit Requirements..... | 159 |
| 23.206.030 | – Additional Permit Requirements..... | 168 |
| 23.206.040 | – Use-Specific Regulations | 170 |
| 23.206.050 | – Protected Uses | 172 |
| 23.206.060 | – M Manufacturing District | 177 |
| 23.206.070 | – MM Mixed Manufacturing District..... | 181 |
| 23.206.080 | – MU-LI Mixed Use-Light Industrial District..... | 182 |
| 23.206.090 | – MU-R Mixed Use-Residential District..... | 185 |
| 23.206.100 | – Permit Findings | 189 |
| 23.208 | Special Purpose Districts | 191 |
| 23.208.010 | – Specific Plan District | 191 |
| 23.208.020 | – Unclassified District..... | 191 |
| 23.210 | Overlay Zones..... | 193 |
| 23.210.010 | – Purpose of Overlay Zones | 193 |
| 23.210.020 | – Hillside Overlay Zone..... | 193 |
| 23.210.030 | – Civic Center District Overlay Zone | 195 |

DIVISION 3 -- CITYWIDE PROVISIONS

| | | |
|---------------|---|------------|
| 23.302 | Supplemental Use Regulations..... | 202 |
| 23.302.010 | – Purpose..... | 202 |
| 23.302.020 | – General Use Regulations..... | 202 |
| 23.302.030 | – Temporary Uses and Structures | 206 |
| 23.302.040 | – Home Occupations | 211 |
| 23.302.050 | – Bed and Breakfast Establishments in Residential Districts | 215 |
| 23.302.060 | – Sidewalk Cafe Seating..... | 216 |

| | |
|---|------------|
| 23.302.070 – Use-Specific Regulations | 217 |
| 23.304 General Development Standards | 224 |
| 23.304.010 – Purpose..... | 224 |
| 23.304.020 – Lot Requirements..... | 224 |
| 23.304.030 – Setbacks | 225 |
| 23.304.040 – Building Separation in Residential Districts..... | 231 |
| 23.304.050 – Building Height..... | 231 |
| 23.304.060 – Accessory Buildings and Enclosed Accessory Structures | 233 |
| 23.304.070 – Unenclosed Accessory Structures in Residential Districts | 236 |
| 23.304.080 – Fences | 236 |
| 23.304.090 – Usable Open Space | 239 |
| 23.304.100 – Site Features in Residential Districts | 240 |
| 23.304.110 – Dormers | 240 |
| 23.304.120 – Lot Coverage | 241 |
| 23.304.130 – Non-Residential Districts Abutting a Residential District | 241 |
| 23.304.140 – Area Plans | 242 |
| 23.306 Accessory Dwelling Units..... | 243 |
| 23.306.010 – Purposes..... | 243 |
| 23.306.020 – Applicability | 243 |
| 23.306.030 – Permit Procedures | 243 |
| 23.308 Emergency Shelters | 244 |
| 23.308.010 – Chapter Purpose | 244 |
| 23.308.020 – Applicability and Nonconformities | 244 |
| 23.308.030 – Required Permits | 244 |
| 23.308.040 – Standards for Emergency Shelters | 245 |
| 23.310 Alcoholic Beverage Sales and Service..... | 248 |
| 23.310.010 – Chapter Purpose | 248 |
| 23.310.020 – General Requirements Excluding Incidental Beer and Wine Service 248 | |
| 23.310.030 – Alcoholic Beverage Service When Incidental to Food Service..... | 249 |
| 23.312 Live/Work | 253 |
| 23.312.010 – Chapter Purpose | 253 |
| 23.312.020 – Applicability | 253 |

| | | |
|---------------|--|------------|
| 23.312.030 | – Required Permits | 254 |
| 23.312.040 | – Standards for Live/Work..... | 255 |
| 23.312.050 | – Findings | 257 |
| 23.314 | Short-Term Rentals | 260 |
| 23.314.010 | – Chapter Purpose | 260 |
| 23.314.020 | – Definitions | 260 |
| 23.314.030 | – Applicability | 261 |
| 23.314.040 | – General Regulations | 261 |
| 23.314.050 | – Operating Standards and Requirements..... | 262 |
| 23.314.060 | – Violations and Remedies | 264 |
| 23.316 | Percentage for Public Art on Private Projects | 266 |
| 23.316.010 | – Chapter Purpose | 266 |
| 23.316.020 | – Applicability | 266 |
| 23.316.030 | – Definitions | 267 |
| 23.316.040 | – General Requirements | 267 |
| 23.316.050 | – Required Permits | 268 |
| 23.316.060 | – In-Lieu Fees | 268 |
| 23.316.070 | – Administrative Regulations (Guidelines) | 268 |
| 23.318 | Urban Agriculture | 269 |
| 23.318.010 | – Chapter Purpose | 269 |
| 23.318.020 | – Applicability | 269 |
| 23.318.030 | – Urban Agriculture Uses and Levels of Discretion..... | 269 |
| 23.318.040 | – Thresholds | 269 |
| 23.318.050 | – Operation Standards..... | 270 |
| 23.318.060 | – Complaints | 270 |
| 23.320 | Cannabis Uses..... | 271 |
| 23.320.010 | – Chapter Purpose | 271 |
| 23.320.020 | – Cannabis Retail..... | 271 |
| 23.320.030 | – Commercial Cannabis Cultivation | 273 |
| 23.320.040 | – Cannabis Manufacturers, Testing Labs, and Distributors | 274 |
| 23.320.050 | – Microbusinesses | 275 |
| 23.322 | Parking and Loading | 276 |

| | | |
|---------------|--|------------|
| 23.322.010 | – Chapter Purpose | 276 |
| 23.322.020 | – Applicability | 276 |
| 23.322.030 | – Required Parking Spaces | 277 |
| 23.322.040 | – General Requirements | 285 |
| 23.322.050 | – Parking Reductions..... | 289 |
| 23.322.060 | – C-DMU Parking and Transportation Demand Management..... | 294 |
| 23.322.070 | – Off-Street Parking Maximums for Residential Development | 296 |
| 23.322.080 | – Parking Layout and Design | 297 |
| 23.322.090 | – Bicycle Parking | 302 |
| 23.322.100 | – On-site Loading Spaces..... | 303 |
| 23.322.110 | – Parking Lots in Residential Districts..... | 305 |
| 23.322.120 | – Transportation Services Fee | 305 |
| 23.324 | Nonconforming Uses, Structures, and Buildings | 307 |
| 23.324.010 | – Chapter Purpose | 307 |
| 23.324.020 | – General | 307 |
| 23.324.030 | – Nonconforming Lots..... | 308 |
| 23.324.040 | – Nonconforming Uses | 308 |
| 23.324.050 | – Nonconforming Structures and Buildings..... | 310 |
| 23.324.060 | – Exemptions | 313 |
| 23.326 | Demolition and Dwelling Unit Control | 315 |
| 23.326.010 | – Chapter Purpose | 315 |
| 23.326.020 | – General Requirements | 315 |
| 23.326.030 | – Eliminating Dwelling Units through Demolition..... | 315 |
| 23.326.040 | – Eliminating Dwelling Units through Conversion and Change of Use 318 | |
| 23.326.050 | – Private Right of Action | 320 |
| 23.326.060 | – Elimination of Residential Hotel Rooms | 320 |
| 23.326.070 | – Demolitions of Non-Residential Buildings | 321 |
| 23.326.080 | – Building Relocations | 322 |
| 23.326.090 | – Limitations..... | 323 |
| 23.328 | Inclusionary Housing | 324 |
| 23.328.010 | – Chapter Purpose and Applicability | 324 |
| 23.328.020 | – General Requirements | 325 |

| | | |
|---------------|---|------------|
| 23.328.030 | – Payment of In-Lieu Fees as an Alternative to Providing Inclusionary Units | 325 |
| 23.328.040 | – Requirements Applicable to All Inclusionary Units | 326 |
| 23.328.050 | – Inclusionary Unit Requirements for Rental Housing Projects | 328 |
| 23.328.060 | – Inclusionary Unit Requirements for Ownership Projects | 329 |
| 23.328.070 | – Special Requirements for Avenues Plan Area | 331 |
| 23.328.080 | – Administrative Regulations | 337 |
| 23.328.090 | – Fees | 337 |
| 23.330 | Density Bonus | 338 |
| 23.330.010 | – Chapter Purpose | 338 |
| 23.330.020 | – Definitions | 338 |
| 23.330.030 | – Application Requirements | 339 |
| 23.330.040 | – Density Bonus Calculations and Procedures | 340 |
| 23.330.050 | – Incentives and Concessions | 340 |
| 23.330.060 | – Waivers and Reductions | 341 |
| 23.330.070 | – Qualifying Units | 341 |
| 23.330.080 | – Regulatory Agreements | 341 |
| 23.332 | Wireless Communication Facilities | 342 |
| 23.332.010 | – Chapter Purpose and Applicability | 342 |
| 23.332.020 | – Definitions | 343 |
| 23.332.030 | – General Requirements | 345 |
| 23.332.040 | – Minimum Application Requirements | 345 |
| 23.332.050 | – Location Requirements | 348 |
| 23.332.060 | – Height Requirements | 348 |
| 23.332.070 | – Design Requirements | 348 |
| 23.332.080 | – Operation and Maintenance Standards | 352 |
| 23.332.090 | – Public Information Requirements | 354 |
| 23.332.100 | – Certification Requirements | 354 |
| 23.332.110 | – Permits and Findings Required for Approval | 357 |
| 23.332.120 | – Cessation of Operations | 358 |
| 23.334 | Transportation Demand Management | 360 |
| 23.334.010 | – Chapter Purpose | 360 |
| 23.334.020 | – Applicability | 360 |

| | | |
|------------|---|-----|
| 23.334.030 | – Transportation Demand Management Program Requirements.... | 361 |
| 23.334.040 | – Monitoring, Reporting and Compliance | 361 |

DIVISION 4 -- PERMITS AND ADMINISTRATION

| | | |
|---------------|---|------------|
| 23.402 | Administrative Responsibility | 365 |
| 23.402.010 | – Purpose..... | 365 |
| 23.402.020 | – Review and Decision-Making Authority..... | 365 |
| 23.402.030 | – Planning and Development Department | 368 |
| 23.402.040 | – Zoning Officer | 368 |
| 23.402.050 | – Landmarks Preservation Commission | 369 |
| 23.402.060 | – Design Review Committee..... | 369 |
| 23.402.070 | – Zoning Adjustments Board..... | 370 |
| 23.402.080 | – Planning Commission | 371 |
| 23.402.090 | – City Council..... | 371 |
| 23.404 | Common Permit Requirements | 373 |
| 23.404.010 | – Purpose and Applicability..... | 373 |
| 23.404.020 | – Application Submittal | 373 |
| 23.404.030 | – Application Review..... | 375 |
| 23.404.040 | – Public Notice | 377 |
| 23.404.050 | – Public Hearings and Decisions | 383 |
| 23.404.060 | – Post-Decision Provisions | 386 |
| 23.404.070 | – Permit Modifications..... | 388 |
| 23.404.080 | – Permit Revocation..... | 389 |
| 23.406 | Specific Permit Requirements..... | 393 |
| 23.406.010 | – Purpose..... | 393 |
| 23.406.020 | – Zoning Certificates | 393 |
| 23.406.030 | – Administrative Use Permits | 394 |
| 23.406.040 | – Use Permits | 396 |
| 23.406.050 | – Variances | 396 |
| 23.406.060 | – Master Use Permits | 398 |
| 23.406.070 | – Design Review | 399 |

| | | |
|---------------|---|------------|
| 23.406.080 | – Modification of Development Standards in West Berkeley Plan Area 404 | |
| 23.406.090 | – Reasonable Accommodations | 405 |
| 23.408 | Green Pathway..... | 409 |
| 23.408.010 | – Purpose..... | 409 |
| 23.408.020 | – Applicability | 409 |
| 23.408.030 | – Eligibility Determination..... | 409 |
| 23.408.040 | – Green Pathway Application..... | 411 |
| 23.408.050 | – General Requirements..... | 412 |
| 23.408.060 | – Requirements for Large Buildings and Hotels..... | 413 |
| 23.408.070 | – Development Standards..... | 413 |
| 23.408.080 | – Streamlined Permitting Process..... | 414 |
| 23.408.090 | – Tolling | 416 |
| 23.408.100 | – Compliance | 416 |
| 23.408.110 | – City Manager Authority to Issue Regulations | 416 |
| 23.410 | Appeals and Certifications | 417 |
| 23.410.010 | – Chapter Purpose | 417 |
| 23.410.020 | – Appeal Subjects and Jurisdiction | 417 |
| 23.410.030 | – Filing and Processing of Appeals..... | 420 |
| 23.410.040 | – Hearing and Decision..... | 421 |
| 23.410.050 | – City Council Certifications | 423 |
| 23.412 | Zoning Ordinance Amendments | 424 |
| 23.412.010 | – Purpose..... | 424 |
| 23.412.020 | – Initiation..... | 424 |
| 23.412.030 | – Application | 424 |
| 23.412.040 | – Planning Commission Hearing and Action..... | 424 |
| 23.412.050 | – City Council Hearing and Action | 425 |
| 23.412.060 | – Findings for Approval | 426 |
| 23.412.070 | – Limitations on Resubmittals after Denial..... | 426 |
| 23.412.080 | – Zoning Map Amendment Notations..... | 427 |
| 23.414 | Nuisance Abatement | 428 |
| 23.414.010 | – Purpose..... | 428 |
| 23.414.020 | – Enforcement Responsibility..... | 428 |

| | | |
|------------|----------------------------------|-----|
| 23.414.030 | – Violations a Misdemeanor..... | 428 |
| 23.414.040 | – Nuisances Prohibited | 428 |
| 23.414.050 | – City Attorney Action | 429 |
| 23.414.060 | – Abatement Procedures | 429 |
| 23.414.070 | – Statements of Violations | 430 |
| 23.414.080 | – Remedies..... | 431 |
| 23.414.090 | – Recovery of Costs..... | 431 |
| 23.414.100 | – Private Right of Action | 432 |

DIVISION 5 -- GLOSSARY

| | | |
|---------------|-----------------------|------------|
| 23.502 | Glossary | 434 |
| 23.502.010 | – Purpose..... | 434 |
| 23.502.020 | – Defined Terms | 434 |
| 23.502.030 | – Acronyms..... | 470 |

Appendix A: Table Relating Ordinance Sections: New Ordinance to Old Ordinance Table

Appendix B: Table Relating Ordinance Sections: Old Ordinance to New Ordinance Table

DIVISION 1: GENERAL PROVISIONS

23.102: Introductory Provisions

- 23.102.010 – Title
- 23.102.020 – Effective Date
- 23.102.030 – Authority
- 23.102.040 – Purpose of the Zoning Ordinance
- 23.102.050 – Applicability and Jurisdiction
- 23.102.060 – Emergencies
- 23.102.070 – Conflicting Provisions
- 23.102.080 – Transitional Provisions
- 23.102.090 – Severability
- 23.102.100 – Rules of Evidence and Procedure

23.104: Interpreting the Zoning Ordinance

- 23.104.010 – Chapter Purpose
- 23.104.020 – Authority
- 23.104.030 – Rules of Interpretation
- 23.104.040 – Threshold Regulations
- 23.104.050 – Zoning Map

23.106: Rules of Measurement

- 23.106.010– Chapter Purpose
- 23.106.020– Lot Coverage
- 23.106.030– Floor Area, Gross
- 23.106.040– Floor Area, Leasable
- 23.106.050– Floor Area Ratio
- 23.106.060– Story
- 23.106.070– Setbacks
- 23.106.080– Building Separation
- 23.106.090– Height

23.108: Zoning Districts and Map

- 23.108.010– Chapter Purpose
- 23.108.020– Zoning Districts
- 23.108.030– Zoning Map

23.102 INTRODUCTORY PROVISIONS

Sections:

- 23.102.010 – Title
- 23.102.020 – Effective Date
- 23.102.030 – Authority
- 23.102.040 – Purpose of the Zoning Ordinance
- 23.102.050 – Applicability and Jurisdiction
- 23.102.060 – Emergencies
- 23.102.070 – Conflicting Provisions
- 23.102.080 – Transitional Provisions
- 23.102.090 – Severability
- 23.102.100 – Rules of Evidence and Procedure

23.102.010 – Title

Municipal Code Title 23 is known and cited as the “City of Berkeley Zoning Ordinance” and referred to in this title as “the Zoning Ordinance.”

23.102.020 – Effective Date

The Zoning Ordinance takes effect and is in force from and after [date of adoption].

23.102.030 – Authority

The Zoning Ordinance is adopted under the authority in California Government Code Section 65850 and all other relevant laws of the State of California. If the Zoning Ordinance refers to a section of state law that is later amended or superseded, the Zoning Ordinance is deemed amended to refer to the amended section or the section that most closely corresponds to the superseded section.

23.102.040 – Purpose of the Zoning Ordinance

- A. **General.** The purpose of the Zoning Ordinance is to implement the General Plan and adopted area plans and to protect the public health, safety, and welfare.
- B. **Specific.** The Zoning Ordinance is intended to:
 - 1. Encourage appropriate land uses and a harmonious relationship among land uses by regulating the location and type of allowed land uses and development.
 - 2. Provide for the appropriate intensity of development by regulating:
 - a. The establishment, density and change of uses;
 - b. The construction of buildings and additions; and
 - c. The size and coverage of lots.

3. Provide for adequate light and air by:
 - a. Limiting building height, bulk, and size; and
 - b. Requiring building setbacks from lot lines and separations between buildings.
4. Provide for adequate usable open space, off-street parking, and off-street loading spaces for specified land uses by:
 - a. Requiring reservations of land and structures for such purposes; and
 - b. Regulating the number, placement, and location of such spaces and areas.
5. Prevent adverse effects of commercial and manufacturing activities by:
 - a. Limiting the hours, intensity, presence of outdoor activities, and other aspects of commercial and manufacturing land uses; and
 - b. Limiting the number and size of commercial and manufacturing land uses in specified districts.
6. Provide review of major changes in buildings by regulating proposals for their demolition, conversion, or relocation.
7. Ensure that the construction and alteration of buildings in Non-Residential Districts is compatible with the existing neighborhoods by requiring Design Review to provide for a pleasing Berkeley environment and encourage excellence in design.
8. Protect Berkeley's existing housing stock by regulating the reduction in size, removal, demolition, or conversion of dwelling units, group living accommodations, and residential hotel rooms.
9. Promote the development of affordable housing for all persons and in particular for persons with low and moderate incomes.
10. Incorporate the substantive provisions of the Neighborhood Preservation Ordinance (Ordinance 4641-NS, not codified), a citizen initiative, to the extent permitted by law.

23.102.050 – Applicability and Jurisdiction

A. Applicability.

1. **General.** The Zoning Ordinance applies to all property in Berkeley, including property owned by the City and other governmental entities, to the full extent permitted by law.
2. **Public Right-of-Way.** The Zoning Ordinance does not apply to uses and structures wholly in the public right-of-way, unless otherwise specified. Such uses and structures must comply with Encroachment Permit regulations in

Municipal Code Chapter 16.18 (Right-of-Way Encroachments and Encroachment Permits).

- B. **Compliance Required.** All land uses and structures in Berkeley must comply with the Zoning Ordinance and all applicable City ordinances and regulations.
- C. **City Actions.** No City department, employee, or official may issue a permits or license for a use or structures that conflicts with the Zoning Ordinance. Any permit or license issued in conflict with the Zoning Ordinance is null and void. Nothing in this subsection is intended to create a mandatory duty under Government Code Section 815.6.
- D. **Approvals Required.** A land use may be established and a structure may be constructed, altered, or moved only after:
 - 1. All applicable project review and approval processes have been followed;
 - 2. All required permits and approvals have been obtained; and
 - 3. All required authorizations to proceed have been issued.
- E. **Other Regulations.** Compliance with the Zoning Ordinance does not relieve an applicant from requirements to comply with other federal, state, and City regulations that also apply to the property.

23.102.060 – Emergencies

- A. **Deviations Allowed.** During a local emergency, the City Council may allow a land use or structure to be established without a Use Permit or other approval ordinarily required by the Zoning Ordinance.
- B. **Approval Procedures.**
 - 1. The City Council may approve such a land use or structure by the same vote required for the adoption of an urgency ordinance upon finding that:
 - a. An emergency exists as defined in Municipal Code Section 2.88.020—
Emergency Defined; and
 - b. The use or structure is required to ameliorate the effects of the emergency.
- C. **Effective Date of Action.** Action by the City Council under this section is effective immediately.
- D. **Post-Emergency Requirements.**
 - 1. Uses and structures permitted under this section are no longer authorized after the City Council declares the emergency has ended.
 - 2. After the emergency has ended, uses and structures shall either:

- a. Be removed or discontinued; or
- b. Apply for all permits and approvals required by the Zoning Ordinance.

23.102.070 – ~~Conflicting Provisions~~ Conflict with Private Agreements

- A. ~~Conflict with State or Federal Regulations.~~ ~~Where the Zoning Ordinance conflicts with state or federal laws, higher law controls over lower law unless local variation is permitted.~~
- B. ~~Conflict with Other City Regulations.~~ ~~Where the Zoning Ordinance conflicts with other ordinances, resolutions, or regulations of the City of Berkeley, the more restrictive controls.~~
- C. **A. Conflict with Private Agreements.** It is not the intent of the Zoning Ordinance to interfere with, abrogate, or annul any easement, covenant, deed restriction, or other agreement between private parties. If the Zoning Ordinance imposes a greater restriction than imposed by a private agreement, the Zoning Ordinance controls. Private agreements may impose greater restrictions than the Zoning Ordinance, ~~but the City is not responsible for~~ and at its sole discretion, the City may monitoring or enforcing private agreements.

23.102.080 – Transitional Provisions

- A. **Relation to Prior Zoning Ordinance.** The Zoning Ordinance supersedes the prior Zoning Ordinance codified in Municipal Code Title 23, including all Title 23 sub-titles and appendices.
- B. **Violations Continue.** A violation of the prior Zoning Ordinance continues to be a violation under this Zoning Ordinance unless the violation is brought into compliance with this Zoning Ordinance.
- C. **Pending Applications.**
 1. If the City deems an application complete but does not take final action on the application before the effective date of this Zoning Ordinance, the application remains subject to prior Zoning Ordinance in effect when the application was deemed complete.
 2. If an application is withdrawn before a decision, any re-application is subject to the requirements of this Zoning Ordinance.
- D. **Approved Projects.**
 1. Permits and other approvals valid on the effective date of this Zoning Ordinance remain valid until their expiration date.

2. Projects with valid permits or approvals shall be completed in compliance with the standards in effect at the time of approval. If the permit or approval expires, future development shall comply with the requirements of this Zoning Ordinance.

E. **Nonconformities.** A parcel, land use, or structure lawfully established before [effective date of Zoning Ordinance] that does not comply with this Zoning Ordinance is considered nonconforming and subject to the requirements in Chapter 23.324 (Nonconforming Uses, Structures, and Buildings).

23.102.090 – Severability

If any portion of the Zoning Ordinance is found invalid or unconstitutional by a court of competent jurisdiction, such decision shall not affect the validity or the constitutionality of the remaining portions of the Zoning Ordinance, which shall remain in full force and effect. The City Council declares that it would have passed the Zoning Ordinance and each of its portions, regardless of whether any portion is declared invalid or unconstitutional.

23.102.100 – Rules of Evidence and Procedure

Except as otherwise expressly provided in this Ordinance, formal rules of evidence or procedure which must be followed in a court of record in this state shall not apply. No action, inaction or recommendation made by any City official, employee, commission, board or other entity under this Ordinance shall be void or invalid or be set aside by any court on the ground of the improper admission or rejection of evidence or by reason of any error, irregularity, informality, neglect or omission (hereinafter called error) as to any matter pertaining to petitions, applications, notices, findings, records, hearings, reports, recommendations, appeals or any matters of procedure whatever, unless after an examination of the entire case, including the evidence, the court is of the opinion that the error complained of was prejudicial, and that by reason of such error the party complaining or appealing sustained and suffered substantial injury, and that a different result would have been probable if such error had not occurred or existed. There shall be no presumption that error is prejudicial or that injury was done if error is shown.

23.104 INTERPRETING THE ZONING ORDINANCE

Sections:

- 23.104.010 – Chapter Purpose
- 23.104.020 – Authority
- 23.104.030 – Rules of Interpretation
- 23.104.040 – Threshold Regulations
- 23.104.050 – Zoning Map

23.104.010 – Chapter Purpose

This chapter establishes rules and procedures for interpreting the Zoning Ordinance to ensure that it is applied and enforced in a consistent manner.

23.104.020 – Authority

The Zoning Officer ~~is responsible for interpreting~~ has the authority to interpret the meaning and applicability of ~~all provisions in~~ the Zoning Ordinance. Zoning Officer interpretations are subject to review and modification by the Zoning Adjustments Board (ZAB) and City Council.

23.104.030 – Rules of Interpretation

- A. **Meaning and Intent.** All language shall be construed according to the purpose and intent set out in Section 23.102.040 (Purpose of the Zoning Ordinance).
- B. **Minimum Requirements.** The Zoning Ordinance establishes minimum requirements to promote the public health, safety, and general welfare. When the Zoning Ordinance provides for discretion on the part of a City official or body, that discretion may be exercised to impose more stringent requirements as necessary to achieve the purpose and intent of the Zoning Ordinance set out Section 23.102.040 (Purpose of the Zoning Ordinance).
- C. **Harmonious Construction.** The City intends that all provisions of the Zoning Ordinance be construed harmoniously. When two or more provisions of the Zoning Ordinance appear to conflict, the City shall construe such provisions to give effect to both, if possible, by harmonizing them with each other. In cases of conflict, the more restrictive shall govern.
- D. **Headings, Illustrations, and Text.** In cases where text conflicts with any heading, table, or figure, the text controls.
- E. **Lists and Examples.** Unless otherwise specifically indicated, lists of items or examples that use terms such as “including,” “such as,” or similar language are intended to provide examples, not to be exhaustive lists of all possibilities.

- F. **Computation of Time.** References to days are consecutive calendar days unless otherwise stated. When business days are referenced, they include only days when City Hall is open. The end of a time period is computed by excluding the first day and including the last day. If the last day is a holiday observed by the City or a City Hall non-business day, that day is excluded.
- G. **Rounding of Fractional Numbers.** Unless otherwise stated, a fraction of one-half or more is rounded to the nearest highest whole number and a fraction of less than one-half is rounded to the next lowest whole number.
- H. **References to Other Regulations, Publications, and Documents.** Whenever reference is made to a resolution, ordinance, regulation, or document, it is construed as a reference to the most recent edition of such resolution, ordinance, regulation, or document, unless specifically stated.
- I. **Technical and Non-Technical Terms.** Words and phrases are construed according to the common and approved usage of the language, but technical words and phrases that may have acquired a peculiar and appropriate meaning in law are construed and understood according to such meaning.
- J. **Terms Not Defined.** If there is a term used in the Zoning Ordinance that is not defined in this title, the Zoning Officer has the authority to provide a definition based upon intended meaning of the undefined term.
- K. **Public Officials and Agencies.** All public officials, bodies, and agencies to which references are made are those of the City of Berkeley, unless otherwise indicated.
- L. **Mandatory and Discretionary Terms.** The words “shall,” “will,” “must,” and “is” are always mandatory. The words “may” and “should” are advisory and discretionary terms.
- M. **Conjunctions.** Unless the context clearly suggests the contrary, conjunctions shall be interpreted as follows:
1. “And” means that all connected items apply.
 2. “And/or” means that the connected words or provisions may apply singularly or in any combination.
 3. “Or” means that any one of the connected items may apply singularly but not in combination.
 4. “Either...or” means that the connected words or provisions shall apply singularly but not in combination.
- N. **Tenses and Plurals.** Words used in one tense (past, present, or future) include all other tenses, unless the context clearly indicates the contrary. The singular includes the plural, and the plural includes the singular.

23.104.040 – Threshold Regulations

To determine if a non-residential project application is subject to a requirement which applies only if certain development or use thresholds are reached, any construction or change of use which is subject to the same regulation and was completed within one year before the application is considered part of the same application.

23.104.050 – Zoning Map

A. Zoning Map Boundaries. Where uncertainty exists as to the boundaries of districts shown on the Zoning Map, the following rules apply:

1. Boundaries shown as approximately following lot lines are construed to follow the lot lines.
2. Boundaries shown as approximately following the centerlines of streets, highways, and alleys are construed to follow the centerlines.
3. Boundaries shown as approximately following city limits are construed to follow city limits.
4. Where a district boundary divides a lot, the location of the boundary is determined by the use of the scale appearing on the Zoning Map unless otherwise indicated by a legal description of the property.

B. Lots Containing Two or More Districts.

1. For lots containing two or more districts, each part of the lot is subject to the regulations of district in which it is located, except as allowed by Paragraph (2) below.
2. The City may apply the setback requirements in one part of a lot to a part of the lot located in another district with a Use Permit, subject to the following:
 - a. The development intensity (residential density and/or floor area ratio) of the project may not exceed the development intensity that would be allowed if the setbacks requirements are not adjusted; and
 - b. Allowed land uses in each part of the lot are only as permitted in the district in which it is located.

23.106 RULES OF MEASUREMENT

Sections:

- 23.106.010– Chapter Purpose
- 23.106.020– Lot Coverage
- 23.106.030– Floor Area, Gross
- 23.106.040– Floor Area, Leasable
- 23.106.050– Floor Area Ratio
- 23.106.060– Story
- 23.106.070– Setbacks
- 23.106.080– Building Separation
- 23.106.090– Height

23.106.010 – Chapter Purpose

This chapter establishes rules for the measurement of standards contained in the Zoning Ordinance.

23.106.020 – Lot Coverage

- A. **Lot Coverage Defined.** Lot coverage means all the area of a lot, as projected on a horizontal plane, which is:
 - 1. Enclosed by the exterior walls of buildings or enclosed accessory structures; or
 - 2. Covered by decks, porches, stairs and/or landings which cover an enclosed space or paved ground area.
- B. **Exclusions.** The lot coverage calculation excludes:
 - 1. Uncovered porches, landings and stairs;
 - 2. Uncovered decks, except that a deck on the roof of a building or accessory structure or over an enclosed space or paved ground area is included in the lot coverage calculation; and
 - 3. The area of the roof of a subterranean structure, when such a structure is not more than 3 feet above finished grade.

23.106.030 – Floor Area, Gross

- A. **Gross Floor Area Defined.** Gross floor area means the total gross horizontal areas of all floors of a building or enclosed structure.
- B. **Basements and Cellars.** Gross floor area includes usable basements and cellars that are either:

1. Below the roof and within the outer surface of the main walls of a main or accessory building (or the centerlines of party walls separating such buildings or portions of buildings); or
 2. Within lines drawn parallel to and 2 feet within the roof line of any building or portion of a building without walls.
- C. **Access Features in Multi-Story Buildings.** For a multi-story building with a covered or enclosed stairways, stairwells, or elevator shafts, the horizontal area of these features is counted only once at the floor level of their greatest area of horizontal extent.
- D. **Excluded Areas.** The following areas are excluded from gross floor area calculation:
1. Covered or uncovered areas used for off-street parking or loading spaces.
 2. Driveways ramps between floors and maneuvering aisles of a multi-level parking garage.
 3. Mechanical, electrical, and telephone equipment rooms below finished grade.
 4. Areas which qualify as usable open space.
 5. Arcades, porticoes, and similar open areas for non-residential uses which are:
 - a. Located at or near street level;
 - b. Accessible to the general public; and
 - c. Are not designed or used as sales, display, storage, service, or production areas.
- E. **Covered Pedestrian Access Features for Non-Residential Uses.** For non-residential uses, gross floor area includes pedestrian access interior walkways or corridors, or interior courtyards, walkways, paseos or corridors covered by a roof or skylight.
- F. **Mezzanines.** Gross floor area includes the floor area of a mezzanine.

23.106.040 – Floor Area, Leasable

- A. **Leasable Floor Area Defined.** Leasable floor area means the total interior floor area of a commercial lease space available for use by a single business.
- B. **Included Areas.** Leasable floor area includes all sales, customer, display, shelving, assembly, seating, counter, kitchen, storage, and office areas.
- C. **Excluded Areas.** Leasable floor area does not include stairs, restrooms, and unenclosed walkways and areas serving more than one lease space such as

hallways, corridors, lobbies, maintenance areas, vestibules and other common areas.

23.106.050 – Floor Area Ratio

- A. **Floor Area Ratio Defined.** Floor area ratio (FAR) means the quotient resulting from division of the gross floor area of all buildings on a lot by the area of the lot. See Figure 23.106-1: Floor Area Ratio.

FIGURE 23.106-1: FLOOR AREA RATIO

*Maximum Floor Area for a FAR of 0.2
on a 43,560 Sq. Ft. Lot = $0.2 \times 43,560$
Sq. Ft. = 8,712 Sq. Ft.*

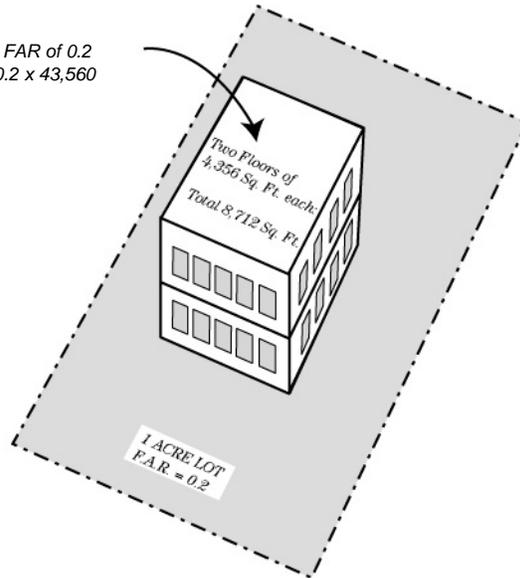

- B. **Development on Contiguous Lots.** In a single integrated development on contiguous lots, the permitted floor area ratio is calculated using the total combined area of all such lots.

23.106.060 – Story

- A. **Story Defined.** A story means the portion of a building included between the upper surface of any floor and the upper surface of the floor next above. See Figure 23.106-2: Story.

FIGURE 23.106-2: STORY

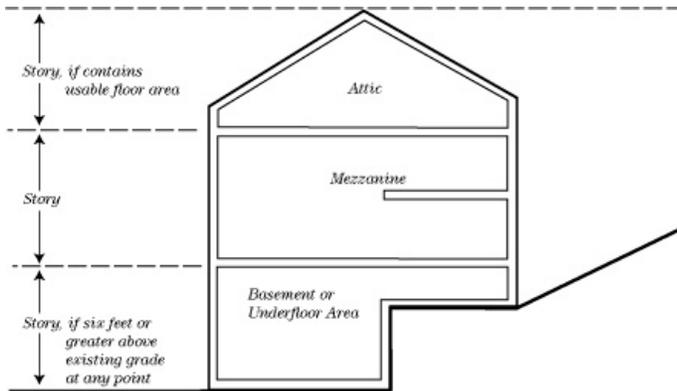

- B. **Topmost Story.** The topmost story of a building is the portion of a building between the floor of the topmost floor and the ceiling or roof above.
- C. **Below Grade Spaces.** If the finished floor level directly above the ceiling of a basement, garage structure, cellar, or unused underfloor space is more than 6 feet above existing grade at any point, such basement, cellar, or unused underfloor space is considered a story.
- D. **Penthouses.** A penthouse used for purposes other than shelter of mechanical equipment or shelter of vertical shaft openings in the roof is considered a story.
- E. **Mezzanines.** When the total floor area of a mezzanine exceeds 33.3 percent of the total floor area in that room, it constitutes an additional story.

23.106.070 – Setbacks

- A. **Measurement.** A required setback is measured as the distance between the surface of a building's outer wall and the applicable lot line.
- B. **Setback Areas.** As shown in Figure 23.106-3: Setbacks, a setback area means the required open area on a lot that is between a lot line and a setback line. A setback area must be unoccupied and unobstructed from the ground upward by any portion of a building or structure except as otherwise permitted by the Zoning Ordinance. Required setback areas are defined as follows:
 1. **Front Setback Area:** The area extending across the full width of the front of a lot from the front lot line to the front setback line.
 2. **Rear Setback Area:** The area extending across the full width of the lot between the rear lot line and the rear setback line.
 3. **Interior Side Setback Area:** The area between an interior side lot line and the side setback line, and extending from the front lot line to the rear lot line.
 4. **Street Side Setback Area:** The area between a street side lot line and the side setback line, and extending from the front lot line to the rear lot line.

FIGURE 23.106-3: SETBACKS

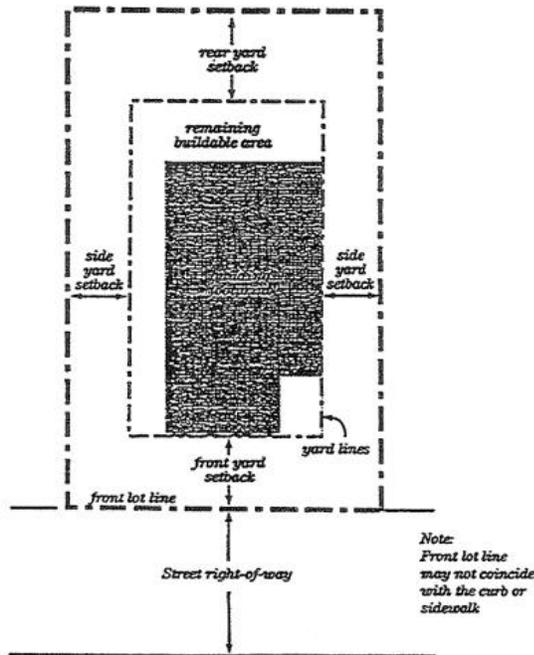

23.106.080 – Building Separation

- A. **Measurement.** Building separation is measured as the distance between the surface of a main building's outer wall and the outer wall surface of the closest neighboring main building.
- B. **Main Buildings with Different Height.** The required building separation between two or more main buildings which are of different heights is that required for the number of stories in the tallest building.

23.106.090 – Height

- A. **Average Building Height.**
 - 1. **Average Building Height:** The vertical distance from the average level of the highest and lowest point of that portion of the lot covered by the building (or, in the case of residential additions, that portion of the lot covered by the addition) to the roof features shown in Table 23.106-1: Average Building Height Measurement. See Figure 23.106-4: Average Building Height.
 - 2. Dormers are not included in the average building height calculation.

TABLE 23.106-1: AVERAGE BUILDING HEIGHT MEASUREMENT

| ROOF TYPE | AVERAGE BUILDING HEIGHT MEASURED TO: |
|------------------------------|--|
| Sloped, hipped, gabled roofs | The average height of the roof between the ridge and where the eave meets the plate |
| Roof with parapet walls | The top of the parapet wall |
| Gambrel roof | The average height of the roof between the ridge and the point where the uppermost change in the roof's slope occurs |
| Mansard roof | The height of the deck |
| Shed roof | The height of the roof ridge |

FIGURE 23.106-4: AVERAGE BUILDING HEIGHT

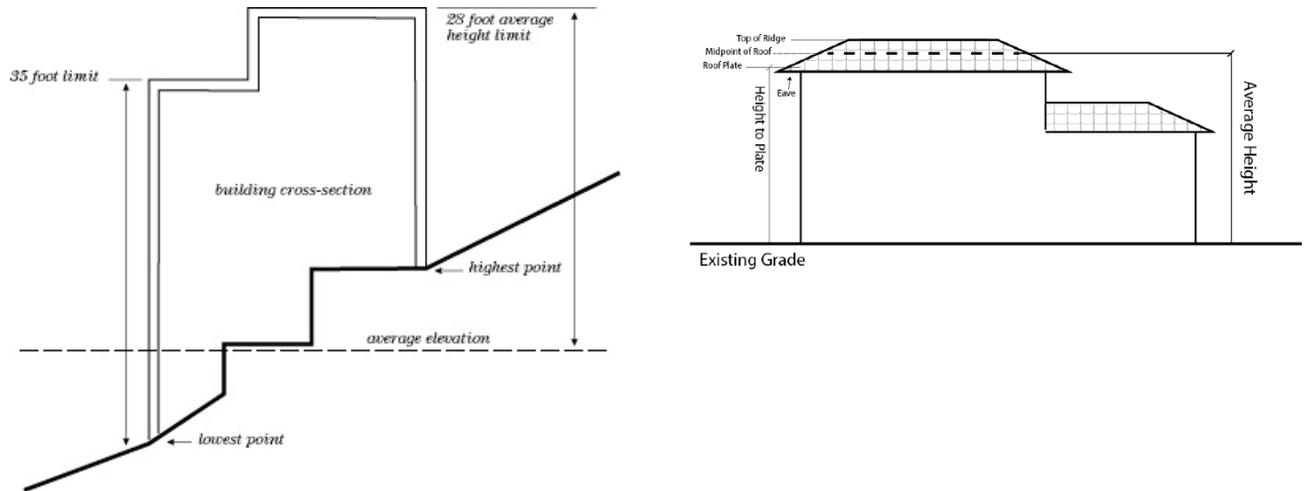

B. Maximum Building Height: The vertical distance of a building at any point, within a given plane, from finished grade to the top of the roof or parapet walls. See Figure 23.106-5: Maximum Building Height

FIGURE 23.106-5: MAXIMUM BUILDING HEIGHT

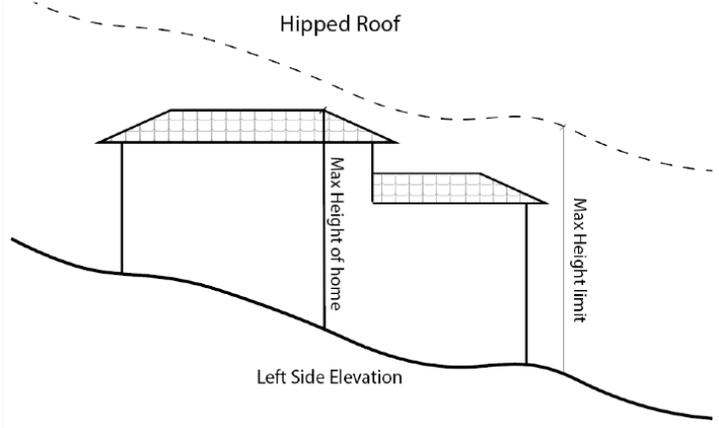

23.108 ZONING DISTRICTS AND MAP

Sections:

- 23.108.010– Chapter Purpose
- 23.108.020– Zoning Districts
- 23.108.030– Zoning Map

23.108.010 – Chapter Purpose

This chapter identifies the districts that apply to land within the Berkeley city limits and establishes the official Berkeley Zoning Map.

23.108.020 – Zoning Districts

- A. **Districts.** Berkeley is divided into districts as shown in Table 23.108-1: Zoning Districts. Unique regulations apply within each district as established in Chapters 23.202 – 23.208 (Zoning Districts).

TABLE 23.108-1: ZONING DISTRICTS

| DISTRICT SYMBOL | NAME OF DISTRICT |
|------------------------------|--|
| Residential Districts | |
| R-1 | Single-Family Residential |
| R-1A | Limited Two-family Residential |
| ES-R | Environmental Safety Residential |
| R-2 | Restricted Two-family Residential |
| R-2A | Restricted Multiple-family Residential |
| R-3 | Multiple-family Residential |
| R-4 | Multi-family Residential |
| R-5 | High Density Residential |
| R-S | Residential Southside |
| R-SMU | Residential Southside Mixed Use |
| Commercial Districts | |
| C-C | Corridor Commercial |
| C-U | University Avenue Commercial |
| C-N | Neighborhood Commercial |
| C-E | Elmwood Commercial |

| DISTRICT SYMBOL | NAME OF DISTRICT |
|--------------------------------|-----------------------------|
| C-NS | North Shattuck Commercial |
| C-SA | South Area Commercial |
| C-T | Telegraph Avenue Commercial |
| C-SO | Solano Avenue Commercial |
| C-DMU | Downtown Mixed-Use |
| C-W | West Berkeley Commercial |
| C-AC | Adeline Corridor Commercial |
| Manufacturing Districts | |
| M | Manufacturing |
| MM | Mixed Manufacturing |
| MU-LI | Mixed Use-Light Industrial |
| MU-R | Mixed Use-Residential |
| Special Districts | |
| S | Specific Plan |
| U | Unclassified |

B. Undesignated Areas. Any area not specifically designated as a district on the Zoning Map is subject to the Unclassified (U) district requirements.

C. Overlay Zones.

1. The Zoning Ordinance and Zoning Map include the overlay zones shown in
2. Table 23.108-2: Overlay Zones. Overlay zones impose additional regulations on properties beyond what is required by the underlying district.
3. As shown in
4. Table 23.108-2: Overlay Zones, provisions for overlay zones that apply to two or more districts are located in Chapter 23.210 (Overlay Zones). Provisions for overlay zones that apply only in one district are located in the Zoning Ordinance chapter for that district.

TABLE 23.108-2: OVERLAY ZONES

| OVERLAY ZONE SYMBOL | NAME OF OVERLAY ZONE | LOCATION IN ZONING ORDINANCE |
|---------------------|----------------------|------------------------------|
|---------------------|----------------------|------------------------------|

| Overlay Zones that Apply in Two or More Districts | | |
|--|---------------|---|
| H | Hillside | 23.210.020– Hillside Overlay Zone |
| C | Civic Center | 23.210.030– Civic Center District Overlay Zone |
| Overlay Zones that Apply in One District | | |
| D | Dealership | 23.204.100.B.5– C-SA South Area Commercial District (Automobile/Motorcycle Sales) |
| DA | Downtown Arts | 23.204.130– C-DMU Downtown Mixed-Use District (Arts Overlay District) |

5. If the overlay zone applies a standard to a property that conflicts with the underlying district, the overlay zone standard governs. If the overlay zone is silent on a standard in the underlying district, the underlying district standard applies.

D. **Vacated Streets.** Where a public street or alley is officially vacated or abandoned, the land area of the street or alley acquires the district classification of the property to which it reverts.

23.108.030 – Zoning Map

- A. **Adoption.** The City Council hereby adopts the City of Berkeley Zoning Map (“Zoning Map”), which establishes the boundaries of all districts and overlay zones provided for in the Zoning Ordinance.
- B. **Incorporation by Reference.** The Zoning Map, including all legends, symbols, notations, references, and other information shown on the map, is incorporated by reference and made a part of the Zoning Ordinance.
- C. **Location.** The Zoning Map is kept, maintained, and updated electronically by the City Clerk, and is available for viewing by the public at the Planning and Development Department and on the official City of Berkeley website.

DIVISION 2: ZONING DISTRICTS

23.202: Residential Districts

- 23.202.010– Chapter Purpose
- 23.202.020– Allowed Land Uses
- 23.202.030– Additional Permit Requirements
- 23.202.040– Use-Specific Regulations
- 23.202.050– R-1 Single-Family Residential District
- 23.202.060– R-1A Limited Two-Family Residential District
- 23.202.070– ES-R Environmental Safety-Residential District
- 23.202.080– R-2 Restricted Two-Family Residential District
- 23.202.090– R-2A Restricted Multiple-Family Residential District
- 23.202.100– R-3 Multiple-Family Residential District
- 23.202.110– R-4 Multi-Family Residential District
- 23.202.120– R-5 High-Density Residential District
- 23.202.130– R-S Residential Southside District
- 23.202.140– R-SMU Residential Southside District

23.204: Commercial Districts

- 23.204.010– Chapter Purpose
- 23.204.020– Allowed Land Uses
- 23.204.030– Additional Permit Requirements
- 23.204.040– Use-Specific Permit Requirements and Regulations
- 23.204.050– C-C Corridor Commercial District
- 23.204.060– C-U University Commercial District
- 23.204.070– C-N Neighborhood Commercial District
- 23.204.080– C-E Elmwood Commercial District
- 23.204.090– C-NS North Shattuck Commercial District
- 23.204.100– C-SA South Area Commercial District
- 23.204.110– C-T Telegraph Avenue Commercial District
- 23.204.120– C-SO Solano Avenue Commercial District
- 23.204.130– C-DMU Downtown Mixed-Use District
- 23.204.140– C-W West Berkeley Commercial District
- 23.204.150– C-AC Adeline Corridor Commercial District

23.206: Manufacturing Districts

- 23.206.010– Chapter Purpose
- 23.206.020– Allowed Land Uses and Permit Requirements

- 23.206.030– Additional Permit Requirements
- 23.206.040– Use-Specific Regulations
- 23.206.050– Protected Uses
- 23.206.060– M Manufacturing District
- 23.206.070– MM Mixed Manufacturing District
- 23.206.080– MU-LI Mixed Use-Light Industrial District
- 23.206.090– MU-R Mixed Use-Residential District
- 23.206.100– Permit Findings

23.208: Special Purpose Districts

- 23.208.010– Specific Plan District
- 23.208.020– Unclassified District

23.210: Overlay Zones

- 23.210.010– Purpose of Overlay Zones
- 23.210.020– Hillside Overlay Zone
- 23.210.030– Civic Center District Overlay Zone

23.202 RESIDENTIAL DISTRICTS

Sections:

- 23.202.010– Chapter Purpose
- 23.202.020– Allowed Land Uses
- 23.202.030– Additional Permit Requirements
- 23.202.040– Use-Specific Regulations
- 23.202.050– R-1 Single-Family Residential District
- 23.202.060– R-1A Limited Two-Family Residential District
- 23.202.070– ES-R Environmental Safety-Residential District
- 23.202.080– R-2 Restricted Two-Family Residential District
- 23.202.090– R-2A Restricted Multiple-Family Residential District
- 23.202.100– R-3 Multiple-Family Residential District
- 23.202.110– R-4 Multi-Family Residential District
- 23.202.120– R-5 High-Density Residential District
- 23.202.130– R-S Residential Southside District
- 23.202.140– R-SMU Residential Southside District

23.202.010 – Chapter Purpose

This chapter identifies allowed land uses, permit requirements, and development standards for residential districts.

23.202.020 – Allowed Land Uses

- A. **Allowed Land Uses.** Table 23.202-1: Allowed Land Uses in Residential Districts identifies allowed land uses and required permits in the Residential Districts. All land uses are defined in Chapter 23.502—Glossary. Permit requirements are described in Chapter 23.406—Specific Permit Requirements.
- B. **Unlisted Land Uses.** Any land use not listed in Table 23.202-1: Allowed Land Uses in Residential Districts is not permitted in the Residential District

| ZC = Zoning Certificate AUP = ADMINISTRATIVE USE PERMIT UP(PH) = Use Permit NP = Not Permitted * Use-Specific Regulations Apply | RESIDENTIAL DISTRICTS | | | | | | | | | | USE-SPECIFIC REGULATIONS APPLIES TO USES WITH AN ASTERISK FOLLOWING THE PERMIT REQUIREMENT (E.G., ZC*) |
|--|-----------------------|-------------|-------------|-------------|-------------|-------------|-------------|-------------|-------------|-------------|--|
| | R-1 | R-1A | ES-R | R-2 | R-2A | R-3 | R-4 | R-5 | R-S | R-SMU | |
| Religious Assembly | UP(PH) | UP(PH) | NP | UP(PH) | UP(PH) | UP(PH) | UP(PH) | UP(PH) | UP(PH) | UP(PH) | |
| School | UP(PH) | UP(PH) | NP | UP(PH) | UP(PH) | UP(PH) | UP(PH) | UP(PH) | UP(PH) | UP(PH) | |
| Commercial Uses | | | | | | | | | | | |
| Alcoholic Beverage Service | NP | NP | NP | NP | NP | NP | NP | NP | NP | UP(PH) * | 23.310—Alcoholic Beverage Sales and Service |
| Food Products Store | NP | NP | NP | NP | NP | NP | NP | NP | NP | UP(PH) * | 23.202.140.B.3—R-SMU Residential Southside District |
| Food Service Establishment | NP | NP | NP | NP | NP | NP | NP | NP | NP | UP(PH) * | 23.302.070.E—Use-Specific Regulations |
| Hotel, Tourist | NP | NP | NP | NP | NP | NP | UP(PH) | UP(PH) | UP(PH) | UP(PH) | |
| Laundromat and Cleaner | NP | NP | NP | NP | NP | NP | NP | NP | NP | UP(PH) | |
| Office | NP | NP | NP | NP | NP | NP | UP(PH) | UP(PH) | NP | UP(PH) | |
| Parking Lot/Structure | UP(PH) * | UP(PH) * | UP(PH) * | UP(PH) * | UP(PH) * | UP(PH) * | UP(PH) * | UP(PH) * | UP(PH) * | UP(PH) * | 23.302.070.G—Unenclosed Accessory Structures in Residential Districts 23.322.100— On-site Loading Spaces |
| Personal and Household Service, General | NP | NP | NP | NP | NP | NP | NP | NP | NP | ZC* | 23.202.140.B.2—R-SMU Residential Southside District |
| Retail, General | NP | NP | NP | NP | NP | NP | UP(PH) * | UP(PH) * | UP(PH) * | UP(PH) * | 23.202.040.B—Use-Specific Regulations |
| Veterinary Clinic | NP | NP | NP | NP | NP | NP | NP | NP | NP | UP(PH) | |
| Video Tape/Disk Rental | NP | NP | NP | NP | NP | NP | NP | NP | NP | UP(PH) | |

| ZC = Zoning Certificate AUP = ADMINISTRATIVE USE PERMIT UP(PH) = Use Permit NP = Not Permitted * Use-Specific Regulations Apply | RESIDENTIAL DISTRICTS | | | | | | | | | | USE-SPECIFIC REGULATIONS APPLIES TO USES WITH AN ASTERISK FOLLOWING THE PERMIT REQUIREMENT (E.G., ZC*) |
|--|---|--------|--------|--------|--------|--------|--------|--------|--------|--------|--|
| | R-1 | R-1A | ES-R | R-2 | R-2A | R-3 | R-4 | R-5 | R-S | R-SMU | |
| Industrial and Heavy Commercial Uses | | | | | | | | | | | |
| Commercial Excavation | UP(PH) | UP(PH) | UP(PH) | UP(PH) | UP(PH) | UP(PH) | UP(PH) | UP(PH) | UP(PH) | UP(PH) | |
| Other Uses | | | | | | | | | | | |
| Accessory Uses | See 23.302.020.A– General Use Regulations | | | | | | | | | | |
| Home Occupations | See 23.302.040– Home Occupations | | | | | | | | | | |
| Short-Term Rental | ZC* | ZC* | NP | ZC* | ZC* | ZC* | ZC* | ZC* | ZC* | ZC* | 23.314—Short-Term Rentals |
| Temporary Uses | See 23.302.030– Temporary Uses and Structures | | | | | | | | | | |
| Urban Agriculture, Low-Impact | ZC* | ZC* | NP | ZC* | ZC* | ZC* | ZC* | ZC* | ZC* | ZC* | 23.318—Urban Agriculture |
| Urban Agriculture, High-Impact | AUP* | AUP* | NP | AUP* | AUP* | AUP* | AUP* | AUP* | AUP* | AUP* | 23.318—Urban Agriculture |
| Wireless Telecommunication Facility | See 23.332—Wireless Communication Facilities | | | | | | | | | | |

- C. **Use-Specific Regulations.** Uses subject to supplemental regulations are shown in Table 23.202-1: Allowed Land Uses in Residential Districts with an asterisk (*) following the permit requirement (e.g., UP*). The Use-Specific Regulations column in Table 23.202-1: Allowed Land Uses in Residential Districts. identifies the location of these regulations in the Zoning Ordinance.

23.202.030 – Additional Permit Requirements

- A. **Residential Additions.** See Section 23.502.020.A– Defined Terms (“A” Terms) for residential addition definitions.

1. Permits Required.

- a. In all Residential Districts except for the ES-R district, residential additions require permits as follows:
 - i. Residential additions (up to 15 percent of lot area or 600 square feet, whichever is less): Zoning Certificate.
 - ii. Major residential additions (more than 15 percent of lot area or 600 square feet, whichever is less): AUP.
- b. In the ES-R district, residential additions require permits as follows:
 - i. Residential additions up to 10 percent of lot area or 200 square feet, whichever is less: Zoning Certificate.
 - ii. Major residential additions more than 10 percent of lot area or 200 square feet, whichever is less: Use Permit.

2. Basis for AUP Decision.

- a. To deny an AUP for a residential addition in all residential districts except for the ES-R district, the review authority must find that although the proposed residential addition satisfies all other Zoning Ordinance requirements, the residential addition would unreasonably obstruct sunlight, air, or views.
- b. To approve an AUP for a residential addition in the ES-R district, the review authority must make the finding in Subsection 23.202.070.H.6– ES-R Environmental Safety-Residential District (Land Use Intensification).

B. Adding Bedrooms.

1. In the R-1, R-1A, R-2, R-2A, and R-3 districts, adding a bedroom to a lot requires permits as follows:
 - a. Adding a first, second, third, or fourth bedroom to a lot: no permit required.
 - b. Adding a fifth bedroom to a lot: AUP.
 - c. Adding a bedroom to a lot beyond the fifth: Use Permit.

2. See Section 23.502.020.B– Defined Terms (“B” Terms) for bedroom definition.
3. In the ES-R district, any alteration to create a new bedroom in a single-family detached home on a single lot requires an AUP. See Section 23.202.070.H.6 (Land Use Intensification) for required finding.

C. **Changes to Nonconforming Structures.** See Section 23.324.050– Nonconforming Structures and Buildings for permits required to modify structures that do not conform to setback, height, and other development standards.

D. **Accessory Structures.** For accessory structure permit requirements, see the following:

1. Section 23.304.060– Accessory Buildings and Enclosed Accessory Structures.
2. Section 23.304.070– Unenclosed Accessory Structures in Residential Districts
3. Section 23.304.080– Fences.

23.202.040 – Use-Specific Regulations

A. **Community Care Facilities.**

1. **Permits Required.** Community care facilities in a Residential District require permits as follows:
 - a. Change of use: Zoning Certificate.
 - b. New construction: Use Permit.
2. **ES-R District.** Community care facilities in the ES-R district must comply with the following standards:
 - a. Maximum of six residents.
 - b. Permitted pursuant to Health and Safety Code Section 1566.3 when occupying a legally established existing single-family dwelling.

B. **General Retail.** In the R-4, R-5, R-S, and R-SMU districts, general retail uses must be:

1. Accessory to another use;
2. Contained within a building with no street access; and
3. Without displays of merchandise visible from the street.

23.202.050 – R-1 Single-Family Residential District

A. **District Purpose.** The purpose of the Single-Family Residential (R-1) district is to:

1. Recognize and protect the existing pattern of development in the low-density, single-family residential areas of the city consistent with the General Plan;

2. Make housing available for persons who desire detached housing and a relatively large amount of usable open space;
3. Protect adjacent properties from unreasonable obstruction of light and air; and
4. Permit community facilities such as religious assembly uses, schools, parks, and libraries which serve the local population and are not detrimental to the immediate neighborhood.

B. Allowed Land Uses. See Table 23.202-1: Allowed Land Uses in Residential Districts

C. Additional Permit Requirements. See Subsection A of Section 23.202.030– Additional Permit Requirements (Residential Additions) and Subsection B of Section 23.202.030– Additional Permit Requirements (Adding Bedrooms).

D. Development Standards.

1. **Basic Standards.** See Table 23.202-2: R-1 Development Standards.
2. **Supplemental Standards.** Supplemental development standards that apply in the R-1 district are noted in Table 23.202-2: R-1 Development Standards.

TABLE 23.202-2: R-1 DEVELOPMENT STANDARDS

| BASIC STANDARDS | | SUPPLEMENTAL STANDARDS |
|--|--------------------------|-------------------------------|
| Lot Area for New Lots, Minimum | 5,000 sq. ft. | 23.304.020– Lot Requirements |
| Usable Open Space per Dwelling Unit, Minimum | 400 sq. ft. | 23.304.090– Usable Open Space |
| Floor Area Ratio, Maximum | No maximum | |
| Main Building Height, Average | | 23.304.050– Building Height |
| New Buildings or Non-Residential Additions | 28 ft. and 3 stories [1] | |
| Residential Additions | 14 ft. [2] | |
| Lot Line Setbacks, Minimum | | 23.304.030– Setbacks |
| Front | 20 ft. | |
| Rear | 20 ft. | |
| Interior Side | 4 ft. | |
| Street Side | 4 ft. | |
| Building Separation, Minimum | No minimum | |
| Lot Coverage, Maximum | 40% | 23.304.120– Lot Coverage |

| BASIC STANDARDS | SUPPLEMENTAL STANDARDS |
|---|------------------------|
| Notes: [1] Maximum 35 ft. with an AUP. [2] Height greater than 14 ft. up to 28 ft. allowed with an AUP. Height greater than 28 ft up to 35 ft allowed with an additional AUP. | |

23.202.060 – R-1A Limited Two-Family Residential District

- A. **District Purpose.** The purpose of the Limited Two-Family Residential (R-1A) district is to:
 1. Recognize and protect the existing pattern of low medium-density residential areas characterized by reasonable open and spacious type of development consistent with the General Plan;
 2. Protect adjacent properties from unreasonable obstruction of light and air;
 3. Allow flexibility in the use of property for residential purposes by permitting two dwelling units on one lot under limited conditions; and
 4. Appropriately regulate the rear and side setback areas for the construction of a dwelling unit in areas west of San Pablo Avenue.
- B. **Allowed Land Uses.** See Table 23.202-1: Allowed Land Uses in Residential Districts
- C. **Additional Permit Requirements.** See Subsection A (Residential Additions) and Subsection B (Adding Bedrooms) of Section 23.202.030– Additional Permit Requirements.
- D. **Development Standards.**
 1. **Basic Standards.** See Table 23.202-3: R-1A Development Standards.
 2. **Supplemental Standards.** Supplemental development standards that apply in the R-1A district are noted in Table 23.202-3: R-1A Development Standards.

TABLE 23.202-3: R-1A DEVELOPMENT STANDARDS

| BASIC STANDARDS | | SUPPLEMENTAL STANDARDS |
|------------------------|-------------------|------------------------------|
| Lot Area, Minimum | | 23.304.020– Lot Requirements |
| New Lots | 5,000 sq. ft. | |
| For Two Dwelling Units | 4,500 sq. ft. [1] | |

| BASIC STANDARDS | | SUPPLEMENTAL STANDARDS |
|--|--------------------------|--|
| Usable Open Space Per Dwelling Unit, Minimum | 400 sq. ft. [2] | 23.304.090– Usable Open Space |
| Floor Area Ratio, Maximum | No maximum | |
| Main Building Height, Average | | 23.304.050– Building Height |
| New Buildings and Non-Residential Additions | 28 ft. and 3 stories [3] | |
| Rear Main Buildings | 22 ft. and 2 stories | |
| Residential Additions | 14 ft. [4] | |
| Lot Line Setbacks, Minimum | | 23.304.030– Setbacks |
| Front | 20 ft. | |
| Rear | 20 ft. | |
| Interior Side | 4 ft. | |
| Street Side | 4 ft. | |
| Interior and Street Side for Rear Main Building | 6 ft. | |
| Building Separation, Minimum | | 23.304.040– Building Separation in Residential Districts |
| 1 story | 8 ft. | |
| 2 stories | 12 ft. | |
| 3 stories | 16 ft. | |
| Lot Coverage, Maximum | | 23.304.120– Lot Coverage |
| Interior and Through Lot | 40% | |
| Corner Lot | 45% | |
| Notes: | | |
| [1] Maximum two units per lot. | | |
| [2] Open space is not required for accessory dwelling unit. | | |
| [3] Maximum 35 ft. with an AUP. | | |
| [4] Height greater than 14 ft. up to 28 ft. allowed with an AUP. Height greater than 28 ft up to 35 ft allowed with an additional AUP. | | |
| | | |

23.202.070 – ES-R Environmental Safety-Residential District

A. District Purpose.

1. **General.** Because of its substandard vehicular access, steep slopes, inadequate water pressure and proximity to the Hayward Fault and vegetated wildlands, the Panoramic Hill area is exceptionally vulnerable to severe damage or destruction from fire and earthquake hazards. Panoramic Hill also includes one of Berkeley's most architecturally significant residential districts, which is listed in the National Register of Historic Places because of its association with the Arts and Crafts movement of the Bay Area Tradition.
2. **Specific.** The specific purpose of the Environmental Safety-Residential (ES-R) district is to:
 - a. Provide a means to implement the General Plan and the Hazard Mitigation Plan to reduce the potential for life loss, injury, and economic damage to Berkeley residents from earthquakes, wildfires, and landslides and to protect the City's unique character and values from being compromised by hazard events by reducing the vulnerability of one of the most unique and inaccessible neighborhoods in the Hill Hazardous Fire Area;
 - b. Protect the lives and property of Panoramic Hill residents in Berkeley and adjoining parts of Oakland and avoid destruction or damage to the natural environment through the application of special development regulations and by ensuring that the review of new development and alterations or additions to existing structures will require analysis and mitigation of geologic, seismic, and fire hazards;
 - c. Limit the uses of land permitted to those which are necessary to serve the housing and access needs of the district's inhabitants and will not put either current or future residents at risk due to the area's inadequate infrastructure and special vulnerability to natural hazards;
 - d. Protect the health and safety of current and future residents by ensuring that no new dwelling units will be built and no land may be subdivided to allow the construction of additional dwelling units until plans are in place that identify the future distribution, location, and extent of development in the Berkeley and Oakland neighborhoods of Panoramic Hill, including provisions to develop and maintain a system of public facilities and services adequate to meet the needs of the future population;
 - e. Establish procedures to ensure that the development review process provides for consideration of the cumulative impact of new construction, alterations, and changes in use that have the potential to increase the population or intensify the use of land in the district together with the impacts of other

projects on Panoramic Hill and within adjacent areas of Berkeley and Oakland;

- f. Restrict the size and occupancy of residential structures by imposing standards that reflect the district's limited capacity to accommodate additional population due to poor access, inadequate infrastructure, vulnerability to natural hazards and the fact that a majority of the existing development does not conform to standards that the City adopted in 1979;
- g. Assure the effective use of emergency measures available to save lives and property;
- h. Give reasonable protection to views and privacy, yet allow appropriate development of all property as long as public services and access are adequate to ensure protection of the health and safety of residents in this vulnerable area; and
- i. Protect the integrity of the Panoramic Hill Historic District by ensuring that alterations to existing buildings and new construction maintain the existing pattern of development, are appropriate to the hillside setting, and do not impair the architectural significance of contributing structures.

B. Interpretation. Nothing in this section is intended or may be construed to overturn, nullify, or affect any recorded limitation of property in favor of the City. In case of conflict between this section and other provisions of the Zoning Ordinance, the more restrictive standards apply.

C. Allowed Land Uses.

- 1. **General.** See Table 23.202-1: Allowed Land Uses in Residential Districts.
- 2. **Rental of Rooms.** Rooms may be rented to a maximum of four persons on a single property. Occupancy of a single dwelling unit by a single household as defined in Chapter 23.502—Glossary is permitted.

D. Additional Permit Requirements. See Section 23.202.030.A— Additional Permit Requirements (Residential Additions) and 23.202.030.B (Adding Bedrooms).

E. Specific Plan Required.

- 1. The City may not approve an AUP, Use Permit, Parcel Map, or Tentative Map to allow a new dwelling unit in the ES-R district until the City Council adopts a Panoramic Hill Specific Plan (“the Plan”) in compliance with applicable law.
- 2. At a minimum, the Plan shall:
 - a. Show the proposed distribution, location, and extent of land uses in the ES-R district and the location and extent of the public facilities and services required to serve the land uses;

- b. Include proposals for water, wastewater, and stormwater systems and for a circulation system adequate to accommodate projected traffic and to provide emergency access to the ES-R district and a program of implementation actions including finance measures necessary to carry out those proposal; and
 - c. Include consideration of the needs and future growth of adjacent areas in the City of Oakland that are now or can feasibly be served by the proposed facilities and services.
3. The Zoning Adjustments Board (ZAB) may approve a new residential unit in the ES-R district only after finding that:
- a. The project is consistent with the Plan; and
 - b. The public facilities and services that the Plan requires have been provided or will be developed as a condition of approval.

F. Environmental Assessment.

1. General.

- a. Due to Panoramic Hill's inadequate infrastructure and special vulnerability to natural hazards, a project that is ordinarily insignificant in its impact on the environment may be significant if it occurs in the ES-R district.
- b. Any discretionary entitlement under the Zoning Ordinance or Subdivision Ordinance (Municipal Code Title 21) will not be considered exempt from environmental review pursuant to the California Environmental Quality Act, except for alterations to create bedrooms and residential additions with a gross floor area of up to 10 percent of the lot area or 200 square feet, whichever is less, and which otherwise meet all applicable standards of this section.
- c. Environmental review shall be based on documentation in the record including the reports as described in this section where applicable. Environmental review shall include consideration of the cumulative impact of new construction, alterations, and changes in use that would result in intensification of land use in combination with other projects on Panoramic Hill and adjacent areas that affect conditions in the area.
- d. For purposes of this section, any project that increases habitable floor area, increases the size or number of sleeping rooms, or has the potential to increase vehicular trips in the area is considered an intensification of land use.

2. **Reports Required.** All applications for construction and development in the ES-R district that are not exempt from environmental review require the following special studies:

- a. **New Construction.** All new construction requires a soils report, a geologic report, and a traffic impact study subject to the requirements in this section.
 - b. **Additions and Accessory Structures.** All new accessory structures and additions to existing structures that require the installation of a foundation require a soils report, subject to the requirements below. The Building Official may waive this requirement for additions with less than 50 square feet of gross floor area or detached non-habitable structures with less than 225 square feet of gross floor area.
3. **Soils Report.** When required by Section 23.202.070.F.2– ES-R Environmental Safety-Residential District (Reports Required), a soils report shall be prepared by a civil engineer registered with the State of California, subject to the following requirements:
 - a. **Contents.** Based upon adequate test borings or excavations, the report shall assess the potential for landslides, ground shaking, and surface faulting. If the soils report indicates the presence of soil conditions which, if not corrected, could lead to structural defects, the report shall recommend corrective action that is likely to prevent structural damage to each structure proposed to be constructed.
 - b. **Review of Report.** The report shall be reviewed and approved by the City before issuance of any discretionary permit under the Zoning Ordinance, or before issuance of a building or grading permit if a discretionary permit is not required. The City may have the soils report independently reviewed by a licensed geotechnical engineer, registered by the state of California, the cost of which shall be borne by the applicant. The report’s recommended action shall be incorporated in the construction of each structure as a condition to the issuance of any building permit.
4. **Geologic Report.** When required by Section 23.202.070.F.2– ES-R Environmental Safety-Residential District (Reports Required), a geologic report in compliance with the Alquist-Priolo Earthquake Fault Zoning Act and related regulations shall be prepared by a certified engineering geologist, subject to the following requirements:
 - a. **Contents.** The report shall identify, describe, and illustrate potential hazards of surface fault rupture, seismic shaking, liquefaction or landslide.
 - b. **Review Conditions.** The report shall review of the local and regional seismic and other geological conditions that significantly affect the proposed use.
 - c. **Assessment.** The report shall assess conditions on or near the site that would contribute to the potential for damage to a proposed use from a seismic or other geological event, or the potential for a new use to create adverse effects upon existing uses because of identified geologic hazards. The

conditions assessed are to include, where applicable, rainfall, soils, slopes, water table, bedrock geology, and any other substrate conditions that may affect seismic response, landslide risk, or liquefaction potential.

- d. **Recommendations.** The report shall recommend building techniques, site preparation and mitigation measures, or setbacks necessary to reduce risks to life and structural damage to property.

5. **Traffic Impact Study.** When required by Section 23.202.070.F.2– ES-R Environmental Safety-Residential District (Reports Required), a traffic study shall be prepared by a qualified traffic engineer or transportation planner for any project that may generate new trips, subject to the following requirements:

- a. **Content.** The report shall identify, describe, and illustrate traffic, parking, and roadway conditions in the project vicinity including design characteristics, topography, parking and traffic regulation, accident rates, and pavement condition and width.
- b. **Assessment.** The report shall assess how the project will affect traffic operations and emergency access based on the size, use, and location, and the proposed site design including driveway locations, turn movements to and from the project site, surrounding uses, locations of nearby intersections, and potential to create unsafe traffic conditions.
- c. **Recommendations.** The report shall recommend measures to reduce the project's impact on traffic safety including site design, location of parking and driveways, and off-site improvements necessary to ensure that the project would not exacerbate traffic safety problems in the area.

G. **Projects in the Panoramic Hill Historic District.**

1. **Landmarks Preservation Commission Review.**

- a. Before the Zoning Officer or the ZAB may take action on AUP or Use Permit for a project in the Panoramic Hill Historic District that involves new construction, exterior alteration, or demolition, the Zoning Officer shall submit the application to the Landmarks Preservation Commission for review and an advisory recommendation.
- b. The purpose of this review is to ensure that proposed buildings, structures, landscaping, and other architectural and site design features are compatible with the design and appearance of existing buildings and structures in the Panoramic Hill Historic District that have established and contribute to its significant character.
- c. This requirement is in addition to but does not supersede any authority or responsibility the Landmarks Preservation Commission has pursuant to Municipal Code Chapter 3.2—Landmarks Preservation Commission.

2. **Parking Expansion.** An AUP is required for any project in the Panoramic Hill Historic District that expands an existing parking area or structure or creates additional parking to comply with the requirements of Chapter 23.322—Parking and Loading.
3. **Findings.** To approve any project involving exterior alterations, construction, demolition or site plan revisions within the Panoramic Hill Historic District, the review authority must find that:
 - a. The proposed work will not adversely affect the exterior architectural features of the subject property or the relationship between the subject structure or feature and its neighboring structures and surroundings, including facade, massing, scale, materials, setbacks, height, orientation, site design, and landscaping; and
 - b. The proposed work will not detract from or adversely affect the special historical, architectural and aesthetic characteristics of the Panoramic Hill Historic District.

H. Development Standards.

1. **Basic Standards.** See
2. Table 23.202-4: ES-R Development Standards
3. **Supplemental Standards.** Supplemental development standards that apply in the ES-R district are noted in
4. Table 23.202-4: ES-R Development Standards.

TABLE 23.202-4: ES-R DEVELOPMENT STANDARDS

| BASIC STANDARDS | | SUPPLEMENTAL STANDARDS |
|--|--------------------------|---|
| Lot Area for New Lots, Minimum | 25,000 sq. ft. | 23.304.020– Lot Requirements 23.202.070.H.3 (Minimum Lot Area Per Dwelling Unit Exception) |
| Usable Open Space Per Dwelling Unit, Minimum | 400 sq. ft. | 23.304.090– Usable Open Space |
| Floor Area Ratio, Maximum | 0.3 | 23.202.070.H.4 (Lots under 5,000 Square Feet) |
| Main Building Height, Average | | 23.304.050– Building Height |
| New Buildings and Non-Residential Additions | 24 ft. and 2 stories [1] | |

| | | |
|--|------------|--|
| Residential Additions | 14 ft. [2] | |
| Main Building Height, Maximum | 35 ft. | |
| Lot Line Setbacks, Minimum | | 23.304.030– Setbacks |
| Front | 20 ft. | |
| Rear | 20 ft. | |
| Interior Side | 15 ft. | |
| Street Side | 15 ft. | |
| Building Separation, Minimum | 30 ft. | 23.304.040– Building Separation in Residential Districts |
| Lot Coverage, Maximum | 30% | 23.304.120– Lot Coverage |
| Notes: | | |
| [1] Maximum building height of 35 ft. allowed with an AUP. See 23.202.070.H.5– ES-R Environmental Safety-Residential District (Height Increases) for findings. | | |
| [2] Height greater than 14 ft. up to 28 ft. allowed with a Use Permit. Height greater than 28 ft up to 35 ft allowed with an additional Use Permit. See 23.202.070.H.5 for findings. | | |

5. **Minimum Lot Area Per Dwelling Unit Exception.** A legally-created lot less than 25,000 square feet may be developed in compliance with ES-R district requirements if, on the effective date of the regulations that made it substandard, it was in single ownership separate from any abutting lot under the same ownership.
6. **Lots Under 5,000 Square Feet.** Lots less than 5,000 square feet are allowed no more than one dwelling unit of no more than 1,000 square feet of gross floor area. Accessory Dwelling Units as defined in Section 23.306 (Accessory Dwelling Units) are not subject to this restriction.
7. **Height Increases.** To approve an AUP or Use Permit to allow an increase in building height, the review authority must find that the increased height is:
 - a. Justified due to the topography of the site; and
 - b. Consistent with the purposes of the ES-R district as stated in Section 23.202.070.A – ES-R Environmental Safety-Residential District (District Purpose).
8. **Land Use Intensification.** To approve any project that increases habitable floor area, increases the size or number of bedrooms, may increase vehicular trips in the area, or will otherwise intensify the use of land in the ES-R district, the review authority must find that the project individually or together with other projects

within or adjacent to the ES-R district will not threaten the safety and general welfare of Panoramic Hill residents.

9. Nonconforming Uses and Structures.

- a. Additions and enlargements to structures that contain a nonconforming use are not permitted.
- b. Alteration, addition, or enlargement of a nonconforming structure that contains a conforming use is allowed provided that:
 - i. The project complies with Section 23.324.050.D– Nonconforming Structures and Buildings (Expansion); and
 - ii. All findings required for the project by the Zoning Ordinance can be made.

23.202.080 – R-2 Restricted Two-Family Residential District

- A. **District Purpose.** The purpose of the Restricted Two-Family Residential (R-2) district is to:
 - 1. Implement the General Plan by encouraging the development of low medium-density residential areas characterized by a reasonably open and spacious type of development with a pattern of housing types ranging from single-family to duplexes and small apartment structures;
 - 2. Make available housing for persons who desire a range of housing choice with a relatively large amount of open space; and
 - 3. Protect adjacent properties from unreasonable obstruction of light and air.
- B. **Allowed Land Uses.** See Table 23.202-1: Allowed Land Uses in Residential Districts
- C. **Additional Permit Requirements.** See Subsection A of Section 23.202.030 (Residential Additions) and Subsection B of 23.202.030 (Adding Bedrooms).
- D. **Development Standards.**
 - 1. **Basic Standards.** See Table 23.202-5: R-2 Lot and Height Standards, Table 23.202-6: R-2 Setback and Building Separation Standards, and Table 23.202-7: R-2 Lot Coverage Standards for development standards in the R-2 district.
 - 2. **Supplemental Standards.** Supplemental development standards that apply in the R-2 district are noted in Table 23.202-5: R-2 Lot and Height Standards, Table 23.202-6: R-2 Setback and Building Separation Standards, and Table 23.202-7: R-2 Lot Coverage Standards.

TABLE 23.202-5: R-2 LOT AND HEIGHT STANDARDS

| BASIC STANDARDS | | SUPPLEMENTAL STANDARDS |
|--|--------------------------|-------------------------------|
| Lot Area, Minimum | | 23.304.020– Lot Requirements |
| New Lots | 5,000 sq. ft. | |
| Per Dwelling Unit | 2,500 sq. ft. [1] | |
| Usable Open Space Per Dwelling Unit, Minimum | 400 sq. ft. | 23.304.090– Usable Open Space |
| Floor Area Ratio, Maximum | No maximum | |
| Main Building Height, Average | | 23.304.050– Building Height |
| New Buildings and Non-Residential Additions | 28 ft. and 3 stories [2] | |
| Residential Additions | 14 ft. [3] | |
| Notes: | | |
| [1] One additional dwelling unit is allowed for any remaining lot area between 2,000 and 2,500 square feet. | | |
| [2] Maximum 35 ft. with an AUP. | | |
| [3] Addition height greater than 14 ft. up to 28 ft. allowed with an AUP. Addition height greater than 28 ft up to 35 ft allowed with an additional AUP. | | |

TABLE 23.202-6: R-2 SETBACK AND BUILDING SEPARATION STANDARDS

| | STANDARDS BY BUILDING STORY | | | SUPPLEMENTAL STANDARDS |
|------------------------------|-----------------------------|-----------------|-----------------|--|
| | 1 ST | 2 ND | 3 RD | |
| Lot Line Setbacks, Minimum | | | | |
| Front | 20 ft. | 20 ft. | 20 ft. | 23.304.030– Setbacks |
| Rear | 20 ft. | 20 ft. | 20 ft. | |
| Interior | 4 ft. | 4 ft. | 6 ft. | |
| Street Side | 10 ft. | 10 ft. | 10 ft. | |
| Building Separation, Minimum | 8 ft. | 12 ft. | 16 ft. | 23.304.040– Building Separation in Residential Districts |

TABLE 23.202-7: R-2 LOT COVERAGE STANDARDS

| | STANDARD BASED ON BUILDING HEIGHT | | | SUPPLEMENTAL STANDARDS |
|--------------------------|-----------------------------------|-----------|-----------|--------------------------|
| | 1 STORY | 2 STORIES | 3 STORIES | |
| Lot Coverage, Maximum | | | | 23.304.120– Lot Coverage |
| Interior and Through Lot | 45% | 40% | 35% | |
| Corner Lot | 50% | 45% | 40% | |

23.202.090 – R-2A Restricted Multiple-Family Residential District

A. **District Purpose.** The purpose of the Restricted Multiple-Family Residential (R-2A) district is to:

1. Implement the General Plan by encouraging the development of medium-density residential areas characterized by small multiple-family and garden-type apartment structures with a maximum of open space consistent with this type of development;
2. Make available housing for persons who desire apartment-type accommodations with a maximum of open space;
3. Protect adjacent properties from unreasonable obstruction of light and air; and
4. Permit only land use intensity which is compatible with existing low-density residential structures and is not detrimental to the immediate neighborhood.

B. **Allowed Land Uses.** See Table 23.202-1: Allowed Land Uses in Residential Districts.

C. **Additional Permit Requirements.** See Subsection A of Section 23.202.030 (Residential Additions) and Subsection B of 23.202.030 (Adding Bedrooms).

D. **Development Standards.**

1. **Basic Standards.** See Table 23.202-8: R-2A Lot and Height Standards, Table 23.202-9: R-2A Setback and Building Separation Standards, and Table 23.202-10: R-2A Lot Coverage Standards.
2. **Supplemental Standards.** Supplemental development standards that apply in the R-2A district are noted in Table 23.202-8: R-2A Lot and Height Standards, Table 23.202-9: R-2A Setback and Building Separation Standards, and Table 23.202-10: R-2A Lot Coverage Standards.

TABLE 23.202-8: R-2A LOT AND HEIGHT STANDARDS

| BASIC STANDARDS | | SUPPLEMENTAL STANDARDS |
|--|--------------------------|--------------------------------|
| Lot Area, Minimum | | |
| New Lots | 5,000 sq. ft. | 23.304.010 |
| Per Dwelling Unit | 1,650 sq. ft. [1] | |
| Usable Open Space Per Dwelling Unit, Minimum | 300 sq. ft. | 23.304.090 |
| Main Building Height, Average | | |
| New Buildings and Non-Residential Additions | 28 ft. and 3 stories [2] | 23.304.050– Building Height |
| Residential Additions | 14 ft. [3] | |
| Notes: | | |
| [1] One additional dwelling unit is allowed for remaining lot area between 1,300 and 1,650 square feet. | | |
| [2] Maximum 35 ft. with an AUP. | | |
| [3] Addition height greater than 14 ft. up to 28 ft. allowed with an AUP. Addition height greater than 28 ft up to 35 ft allowed with an additional AUP. | | |

TABLE 23.202-9: R-2A SETBACK AND BUILDING SEPARATION STANDARDS

| | STANDARDS BY BUILDING STORY | | | SUPPLEMENTAL STANDARDS |
|------------------------------|------------------------------------|-----------------------|-----------------------|---|
| | 1ST | 2ND | 3RD | |
| Lot Line Setbacks, Minimum | | | | 23.304.030– Setbacks |
| Front | 15 ft. | 15 ft. | 15 ft. | |
| Rear | 15 ft. | 15 ft. | 15 ft. | |
| Interior | 4 ft. | 4 ft. | 6 ft. | |
| Street Side | 6 ft. | 8 ft. | 10 ft. | |
| Building Separation, Minimum | 8 ft. | 12 ft. | 16 ft. | 23.304.040– Building Separation in Residential Districts |

TABLE 23.202-10: R-2A LOT COVERAGE STANDARDS

| | STANDARD BASED ON BUILDING HEIGHT | | | SUPPLEMENTAL STANDARDS |
|---------------------------|-----------------------------------|-----------|-----------|------------------------|
| | 1 STORY | 2 STORIES | 3 STORIES | |
| Lot Coverage, Maximum | | | | 23.304.120 |
| Interior and Through Lots | 45% | 40% | 35% | |
| Corner Lots | 50% | 45% | 40% | |

23.202.100 – R-3 Multiple-Family Residential District

- A. **District Purpose.** The purpose of the Multiple-Family Residential (R-3) district is to:
1. Implement the General Plan by encouraging development of relatively high-density residential areas;
 2. Make available housing for persons who desire both convenience of location and a reasonable amount of usable open space;
 3. Protect adjacent properties from unreasonable obstruction of light and air;
 4. Permit the construction of residential structures, such as dormitories, fraternity and sorority houses, boarding and rooming houses, which meet City requirements for this type of housing; and
 5. Permit the construction of specialized care and treatment facilities such as senior congregate housing, nursing homes, and hospitals when such are not detrimental to the immediate neighborhood.
- B. **Allowed Land Uses.** See Table 23.202-1: Allowed Land Uses in Residential Districts.
- C. **Additional Permit Requirements.** See Subsections A of Section 23.202.030 (Residential Additions) and 23.202.030 (Adding Bedrooms).
- D. **Design Review.** Within the Southside Plan boundaries, all mixed-use and community and institutional use projects, as defined in Chapter 23.502 Glossary require Design Review. See Figure 23.202-1: R-3 Areas Subject to Design Review.

FIGURE 23.202-1: R-3 AREAS SUBJECT TO DESIGN REVIEW



Multiple-family Residential (R-3)

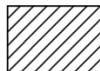

Design Review In Southside Plan Area

Parcel boundaries as of [adoption date]

E. Development Standards.

1. **Basic Standards.** See Table 23.202-11: R-3 Lot and Height Standards, Table 23.202-12: R-3 Setback and Building Separation Standards, and Table 23.202-13: R-3 Lot Coverage Standards.
2. **Supplemental Standards.** Supplemental development standards that apply in the R-3 district are noted in Table 23.202-11: R-3 Lot and Height Standards, Table 23.202-12: R-3 Setback and Building Separation Standards, and Table 23.202-13: R-3 Lot Coverage Standards.

TABLE 23.202-11: R-3 LOT AND HEIGHT STANDARDS

| BASIC STANDARDS | | SUPPLEMENTAL STANDARDS |
|---|-----------------|------------------------------|
| Lot Area, Minimum | | 23.304.020– Lot Requirements |
| New Lots | 5,000 sq. ft. | |
| Per Group Living Accommodation Resident | 350 sq. ft. [1] | |
| Usable Open Space, Minimum | | 23.304.090– Usable Open |
| Per Dwelling Unit | 200 sq. ft. | |

| BASIC STANDARDS | | SUPPLEMENTAL STANDARDS |
|---|----------------------|--------------------------------|
| Per Group Living Accommodation Resident | 90 sq. ft. | Space |
| Floor Area Ratio, Maximum | No maximum | |
| Main Building Height, Average | | 23.304.050– Building Height |
| New Buildings and Non-Residential Additions | 35 ft. and 3 stories | |
| Residential Additions | 16 ft. [2] | |
| Notes: [1] One additional resident is allowed for remaining lot area between 200 and 350 square feet. [2] Maximum 35 ft. with an AUP. | | |

TABLE 23.202-12: R-3 SETBACK AND BUILDING SEPARATION STANDARDS

| | STANDARDS BY BUILDING STORY | | | SUPPLEMENTAL STANDARDS |
|------------------------------|-----------------------------|-----------------|-----------------|--------------------------------|
| | 1 ST | 2 ND | 3 RD | |
| Lot Line Setbacks, Minimum | | | | 23.304.030– Setbacks |
| Front | 15 ft. | 15 ft. | 15 ft. | |
| Rear | 15 ft. | 15 ft. | 15 ft. | |
| Interior Side | 4 ft. | 4 ft. | 6 ft. | |
| Street Side | 6 ft. | 8 ft. | 10 ft. | |
| Building Separation, Minimum | 8 ft. | 12 ft. | 16 ft. | 23.304.040– Building Height |

TABLE 23.202-13: R-3 LOT COVERAGE STANDARDS

| | STANDARD BASED ON BUILDING HEIGHT | | | SUPPLEMENTAL STANDARDS |
|--------------------------|-----------------------------------|-----------|-----------|--------------------------|
| | 1 STORY | 2 STORIES | 3 STORIES | |
| Lot Coverage, Maximum | | | | 23.304.120– Lot Coverage |
| Interior and Through Lot | 45% | 45% | 30% | |
| Corner Lot | 50% | 50% | 45% | |

3. **Increase in Lot Coverage.** Lot coverage may be increased for a project in an R-3 district located within the Southside Plan boundaries if an AUP is obtained with one or both of the following findings:
 - a. The increased coverage would enable a new rear dwelling on the lot; or
 - b. It would enable moving a historic building onto the lot.

23.202.110 – R-4 Multi-Family Residential District

- A. **District Purpose.** The purpose of the Multi-Family Residential (R-4) district is to:
 1. Implement the General Plan by encouraging development of relatively high-density residential areas;
 2. Make available housing for persons who desire both convenience of location and a reasonable amount of usable open space;
 3. Protect adjacent properties from unreasonable obstruction of light and air;
 4. Permit the construction of residential structures, such as residential hotels, which will provide housing opportunities for transient or seasonal residents; and
 5. Permit the construction of institutional and office uses that are not detrimental to the immediate neighborhood.
- B. **Allowed Land Uses.** See Table 23.202-1: Allowed Land Uses in Residential Districts.
- C. **Additional Permit Requirements.** See Section 23.202.030.A– Additional Permit Requirements (Residential Additions).
- D. **Design Review.** All commercial and mixed-use projects in the R-4 district require Design Review.
- E. **Development Standards.**
 1. **Basic Standards.** See Table 23.202-14: R-4 Lot and Height Standards, Table 23.202-15: R-4 Setback and Building Separation Standards, and Table 23.202-16: R-4 Lot Coverage Standards.
 2. **Supplemental Standards.** Supplemental development standards that apply in the R-4 district are noted in Table 23.202-14: R-4 Lot and Height Standards, Table 23.202-15: R-4 Setback and Building Separation Standards, and Table 23.202-16: R-4 Lot Coverage Standards.

TABLE 23.202-14: R-4 LOT AND HEIGHT STANDARDS

| BASIC STANDARDS | | SUPPLEMENTAL STANDARDS |
|--|--------------------------|-------------------------------|
| Lot Area, Minimum | | 23.304.020– Lot Requirements |
| New Lots | 5,000 sq. ft. | |
| Per Group Living Accommodation Resident | 350 sq. ft. [1] | |
| Usable Open Space, Minimum | | 23.304.090– Usable Open Space |
| Per Dwelling Unit | 200 sq. ft. | |
| Per Group Living Accommodation Resident | 90 sq. ft. | |
| Floor Area Ratio, Maximum | No maximum | |
| Main Building Height, Average | | 23.304.050– Building Height |
| New Buildings and Non-Residential Additions | 35 ft. and 3 stories [2] | |
| Residential Additions | 16 ft. [3] | |
| Notes: | | |
| [1] One additional resident is allowed for remaining lot area between 200 and 350 square feet. | | |
| [2] Maximum 65 ft and six stories allowed with Use Permit. | | |
| [3] Height greater than 14 ft. up to 35 ft. allowed with an AUP. Height greater than 35 ft. up to 65 ft allowed with a Use Permit. | | |

TABLE 23.202-15: R-4 SETBACK AND BUILDING SEPARATION STANDARDS

| | STANDARDS BY BUILDING STORY | | | | | | SUPPLEMENTAL STANDARDS |
|------------------------------|-----------------------------|-----------------|-----------------|-----------------|-----------------|-----------------|--|
| | 1 ST | 2 ND | 3 RD | 4 TH | 5 TH | 6 TH | |
| Lot Line Setbacks, Minimum | | | | | | | 23.304.030– Setbacks |
| Front | 15 ft. | 15 ft. | 15 ft. | 15 ft. | 15 ft. | 15 ft. | |
| Rear | 15 ft. | 15 ft. | 15 ft. | 17 ft. | 19 ft. | 21 ft. | |
| Interior Side | 4 ft. | 4 ft. | 6 ft. | 8 ft. | 10 ft. | 12 ft. | |
| Street Side | 6 ft. | 8 ft. | 10 ft. | 12 ft. | 14 ft. | 15 ft. | |
| Building Separation, Minimum | 8 ft. | 12 ft. | 16 ft. | 20 ft. | 24 ft. | 28 ft. | 23.304.040– Building Separation in Residential Districts |

TABLE 23.202-16: R-4 LOT COVERAGE STANDARDS

| | STANDARD BASED ON BUILDING HEIGHT | | | | | | SUPPLEMENTAL STANDARDS |
|--------------------------|-----------------------------------|-----------|-----------|-----------|-----------|-----------|-----------------------------|
| | 1 STORY | 2 STORIES | 3 STORIES | 4 STORIES | 5 STORIES | 6 STORIES | |
| Lot Coverage, Maximum | | | | | | | 23.304.120– Lot Coverage |
| Interior and Through Lot | 45% | 45% | 40% | 35% | 35% | 35% | |
| Corner Lot | 50% | 50% | 45% | 40% | 40% | 40% | |

23.202.120 – R-5 High-Density Residential District

- A. District Purpose.** The purpose of the High-Density Residential (R-5) district is to:
1. Foster development of high-density, multi-story residential areas close to major shopping, transportation, and employment centers, in accordance with the General Plan;
 2. Make available housing for persons who desire convenience of location and who require relatively small amounts of usable open space;
 3. Assure adequate light, air, privacy and usable open space to promote and protect their physical and mental health;
 4. Protect adjacent properties from unreasonable obstruction of light and air;
 5. Permit the construction of residential structures, such as apartments and hotels, which provide housing opportunities for transient or seasonal residents; and
 6. Permit the construction of institutional and office uses when such uses are not detrimental to the immediate neighborhood.
- B. Allowed Land Uses.** See Table 23.202-1: Allowed Land Uses in Residential Districts.
- C. Additional Permit Requirements.** See Section 23.202.030.A– Additional Permit Requirements (Residential Additions).
- D. Development Standards.**
1. **Basic Standards.** See Table 23.202-17: R-5 Lot and Height Standards, Table 23.202-18: R-5 Setback and Building Separation Standards, and Table 23.202-19: R-5 Lot Coverage Standards.
 2. **Supplemental Standards.** Supplemental development standards that apply in the R-5 district are noted in Table 23.202-17: R-5 Lot and Height Standards, Table 23.202-18: R-5 Setback and Building Separation Standards, and Table

23.202-19: R-5 Lot Coverage Standards.

TABLE 23.202-17: R-5 LOT AND HEIGHT STANDARDS

| BASIC STANDARDS | | SUPPLEMENTAL STANDARDS |
|--|--------------------------|-------------------------------|
| Lot Area, Minimum | | 23.304.020– Lot Requirements |
| New Lots | 5,000 sq. ft. | |
| Per Group Living Accommodation Resident | 175 sq. ft. [1] | |
| Usable Open Space, Minimum | | 23.304.090– Usable Open Space |
| Per Dwelling Unit | 100 sq. ft. | |
| Per Group Living Accommodation Resident | 35 sq. ft. | |
| Floor Area Ratio, Maximum | No maximum | |
| Main Building Height, Average | | 23.304.050– Building Height |
| New Construction | 40 ft. and 4 stories [2] | |
| Residential Additions | 18 ft. [3] | |
| Notes: | | |
| [1] One additional person is allowed for remaining lot area between 100 and 175 square feet. | | |
| [2] Maximum 65 feet and 6 stories allowed with a Use Permit. | | |
| [3] Height greater than 18 ft. up to 40 ft. allowed with an AUP. Height greater than 40 ft. up to 65 ft allowed with a Use Permit. | | |

TABLE 23.202-18: R-5 SETBACK AND BUILDING SEPARATION STANDARDS

| | STANDARDS BY BUILDING STORY | | | | | | SUPPLEMENTAL STANDARDS |
|------------------------------|-----------------------------|-----------------|-----------------|-----------------|-----------------|-----------------|--|
| | 1 ST | 2 ND | 3 RD | 4 TH | 5 TH | 6 TH | |
| Lot Line Setbacks, Minimum | | | | | | | 23.304.030– Setbacks |
| Front | 10 ft. | 10 ft. | 10 ft. | 10 ft. | 10 ft. | 10 ft. | |
| Rear | 15 ft. | 15 ft. | 15 ft. | 17 ft. | 19 ft. | 21 ft. | |
| Interior | 4 ft. | 4 ft. | 6 ft. | 8 ft. | 10 ft. | 12 ft. | |
| Street Side | 6 ft. | 8 ft. | 10 ft. | 10 ft. | 10 ft. | 10 ft. | |
| Building Separation, Minimum | 8 ft. | 12 ft. | 16 ft. | 20 ft. | 24 ft. | 28 ft. | 23.304.040– Building Separation in Residential Districts |

TABLE 23.202-19: R-5 LOT COVERAGE STANDARDS

| | STANDARD BASED ON BUILDING HEIGHT | | | | | | SUPPLEMENTAL STANDARDS |
|---------------------------|-----------------------------------|-----------|-----------|-----------|-----------|-----------|-----------------------------|
| | 1 STORY | 2 STORIES | 3 STORIES | 4 STORIES | 5 STORIES | 6 STORIES | |
| Lot Coverage, Maximum | | | | | | | 23.304.120– Lot Coverage |
| Interior and Through Lots | 55% | 55% | 50% | 45% | 40% | 40% | |
| Corner Lots | 60% | 60% | 55% | 50% | 45% | 45% | |

23.202.130 – R-S Residential Southside District

A. **District Purpose.** The purpose of the Residential Southside (R-S) district is to:

1. Implement General Plan and Southside Plan policy by encouraging relatively high and moderate-density, multi-story residential development close to major shopping, transportation, and employment centers;
2. Make housing available for persons who desire a convenient location with relatively small amounts of usable open space, yet assure adequate light, air, privacy and usable open space to promote and protect their physical and mental health;
3. Protect adjacent properties from unreasonable obstruction of light and air;
4. Permit the construction of residential structures, such as apartments, and residential hotels, which will provide housing opportunities for transient or seasonal residents;
5. Encourage the construction of new housing on vacant properties and surface parking lots;
6. Encourage the redevelopment of single-story structures that are not historically significant resources with more dense housing development; and
7. Protect and enhance historically and architecturally significant buildings by ensuring that new development and alterations complement their existing architectural character.

B. **Allowed Land Uses.** See Table 23.202-1: Allowed Land Uses in Residential Districts.

C. **Additional Permit Requirements.** See Section 23.202.030.A– Additional Permit Requirements (Residential Additions).

D. **Design Review.** All mixed-use and community and institutional projects, as defined in Chapter 23.502—Glossary, require Design Review.

E. **Development Standards.**

1. **Basic Standards.** See
2. Table 23.202-20: R-S Lot and Height Standards, Table 23.202-21: R-S Setback and Building Separation Standards, and Table 23.202-22: R-S Lot Coverage Standards.
3. **Supplemental Standards.** Supplemental development standards that apply in the R-S district are noted in
4. Table 23.202-20: R-S Lot and Height Standards, Table 23.202-21: R-S Setback and Building Separation Standards, and Table 23.202-22: R-S Lot Coverage Standards.

TABLE 23.202-20: R-S LOT AND HEIGHT STANDARDS

| BASIC STANDARDS | | SUPPLEMENTAL STANDARDS |
|---|--------------------------|-------------------------------|
| Lot Area, Minimum | | 23.304.020– Lot Requirements |
| New Lots | 5,000 sq. ft. | |
| Per Group Living Accommodation Resident | 350 sq. ft. [1] | |
| Usable Open Space, Minimum | | 23.304.090– Usable Open Space |
| Per Dwelling Unit | 50 sq. ft. | |
| Per Group Living Accommodation Resident | 20 sq. ft. | |
| Floor Area Ratio, Maximum | No maximum | |
| Main Building Height, Maximum | | 23.304.050– Building Height |
| New Construction | 35 ft. and 3 stories [2] | |
| Residential Additions | 16 ft. [3] | |

Notes:

- [1] One additional person is allowed for remaining lot area between 350 and 200 square feet.
- [2] Maximum 45 feet and 4 stories allowed with a Use Permit if at least 50 percent of the total building floor area is designated for residential use and the ZAB finds that the project meets the purpose of the district.
- [3] Maximum 35 feet and 3 stories allowed with an AUP. Maximum 45 feet and 4 stories allowed with a Use Permit if at least 50 percent of the total building floor area is designated for residential use and the ZAB finds that the project meets the purpose of the district.

TABLE 23.202-21: R-S SETBACK AND BUILDING SEPARATION STANDARDS

| | STANDARDS BY BUILDING STORY | | | | SUPPLEMENTAL STANDARDS |
|------------------------------|-----------------------------|-----------------|-----------------|-----------------|--|
| | 1 ST | 2 ND | 3 RD | 4 TH | |
| Lot Line Setback, Minimum | | | | | 23.304.030– Setbacks |
| Front | 10 ft. | 10 ft. | 10 ft. | 10 ft. | |
| Rear | 10 ft. | 10 ft. | 10 ft. | 17 ft. | |
| Interior | 4 ft. | 4 ft. | 6 ft. | 8 ft. | |
| Street Side | 6 ft. | 8 ft. | 10 ft. | 10 ft. | |
| Building Separation, Minimum | 8 ft. | 12 ft. | 16 ft. | 20 ft. | 23.304.040– Building Separation in Residential Districts |

TABLE 23.202-22: R-S LOT COVERAGE STANDARDS

| | STANDARD BASED ON BUILDING HEIGHT | | | | SUPPLEMENTAL STANDARDS |
|--------------------------|-----------------------------------|-----------|-----------|-----------|-----------------------------|
| | 1 STORY | 2 STORIES | 3 STORIES | 4 STORIES | |
| Lot Coverage, Maximum | | | | | 23.304.120– Lot Coverage |
| Interior and Through Lot | 65% | 65% | 60% | 55% | |
| Corner Lot | 70% | 70% | 65% | 60% | |

23.202.140 – R-SMU Residential Southside District

A. **District Purpose.** The purpose of the Residential Southside Mixed Use (R-SMU) district is to:

1. Implement General Plan and Southside Plan policy by encouraging high-density, multi-story residential development close to major shopping, transportation, and employment centers;
2. Make housing available for persons who desire a convenient location, but who require relatively small amounts of usable open space, yet assure adequate light, air, privacy and usable open space to promote and protect their physical and mental health;
3. Protect adjacent properties from unreasonable obstruction of light and air;
4. Permit the construction of residential structures, such as apartments and residential hotels, which will provide housing opportunities for transient or seasonal residents;
5. Permit the construction of institutional, neighborhood serving retail, and office uses when such uses are not detrimental to the immediate neighborhood;
6. Provide locations for relocation of office space from other locations in the Southside Plan area;
7. Encourage the construction of new housing and mixed-use development on vacant properties and surface parking lots;
8. Encourage the redevelopment of single-story structures that are not historically significant resources with housing and mixed-use development; and
9. Protect and enhance historically and architecturally significant buildings by ensuring that new development and alterations complement their existing architectural character.

B. **Allowed Land Uses.**

1. **General.** See Table 23.202-1: Allowed Land Uses in Residential Districts.
2. **Commercial Uses.**
 - a. Any project that creates new commercial floor area requires a Use Permit. Creating new floor area includes constructing a new building or accessory building, adding floor area to an existing building, or installing a new floor or mezzanine level within or onto an existing building.
 - b. Tenant space reconfiguration of an existing commercial building requires an AUP.
3. **Food Product Stores.** Food product stores are limited to 3,000 square feet in the R-SMU district.

C. **Additional Permit Requirements.** See Section 23.202.030.A– Additional Permit Requirements (Residential Additions).

D. **Design Review.** All commercial, mixed-use, and community and institutional use projects, as defined in Chapter 23.502—Glossary, require Design Review.

E. **Development Standards.**

1. **Basic Standards.**

- a. Table 23.202-23: R-SMU Lot and Height Standards shows lot and height standards that apply in all areas in the R-SMU district.

TABLE 23.202-23: R-SMU LOT AND HEIGHT STANDARDS

| BASIC STANDARDS | | SUPPLEMENTAL STANDARDS |
|---|----------------------|-------------------------------|
| Lot Area, Minimum | | 23.304.020– Lot Requirements |
| New Lots | 5,000 sq. ft. | |
| Per Group Living Accommodation Resident | 175 sq. ft. [1] | |
| Floor Area Ratio, Maximum | No maximum | |
| Usable Open Space, Minimum | | 23.304.090– Usable Open Space |
| Per Dwelling Unit | 40 sq. ft. | |
| Per Group Living Accommodation Resident | 20 sq. ft. | |
| Main Building Height, Maximum | | 23.304.050– Building Height |
| New Buildings | 60 ft. and 4 stories | |
| Residential Additions | 16 ft. [2] | |
| Notes: | | |
| [1] One additional person is allowed for between 100 and 175 square feet of remaining lot area. | | |
| [2] Maximum 60 feet and 4 stories allowed with an AUP, or up to the district limit with a UP(PH). | | |

- b. Table 23.202-24 and Table 23.202-25 show setback, building separation, and lot coverage standards that apply to main buildings:

- i.* With dwelling units or group living accommodations; or
- ii.* Are located north of Durant Avenue

2. **Supplemental Standards.** Supplemental development standards that apply in the R-SMU district are noted in Table 23.202-23 to Table 23.202-27.
3. **Increase in Building Height.**
 - a. The ZAB may approve a Use Permit to increase the allowed height of a main building or residential addition in the two subareas shown in Figure 23.202-2: R-SMU Subareas. Maximum allowed height is:
 - i. 75 feet and 5 stories in Subarea One; and
 - ii. 65 feet and 5 stories in Subarea Two.

FIGURE 23.202-2: R-SMU SUBAREAS

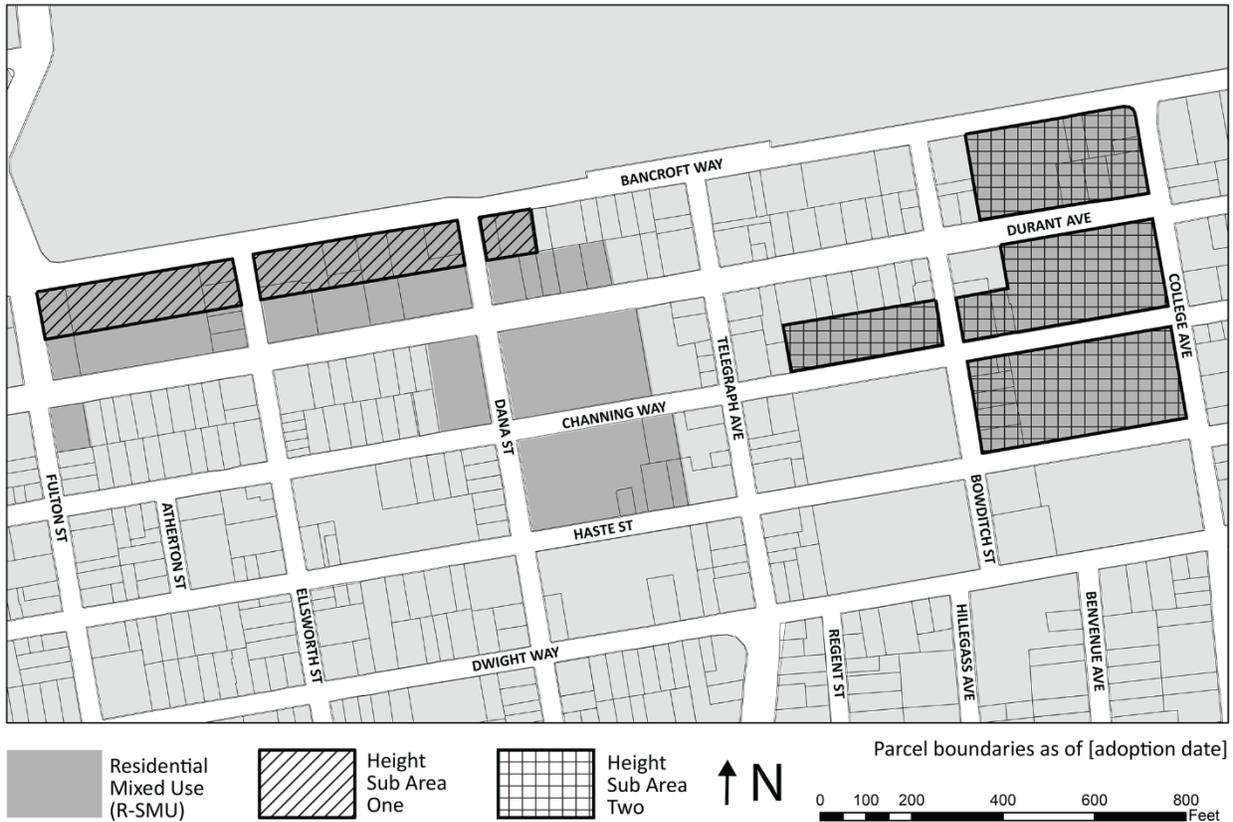

- b. To approve the Use Permit for increased building height, the ZAB must make the following findings:
 - i. At least 50 percent of the total floor area is designated for residential use.
 - ii. The project meets the purposes of the R-SMU district as stated in Section 23.202.140.A (District Purpose).
4. **Increase in Density for Group Living Accommodation.** The ZAB may approve a Use Permit to increase the density of a group living accommodation use (i.e.,

decrease the minimum lot area per group living accommodation room as shown in Table 23.202-23: R-SMU Lot and Height Standards). To approve the Use Permit, the ZAB must make the following findings:

- a. At least 50 percent of the total building floor area is designated for residential use.
- b. The increased density will not be detrimental to the immediate neighborhood.
- c. The project meets the purposes of the R-SMU district as stated in Section 23.202.140.A – R-SMU Residential Southside District (District Purpose).

TABLE 23.202-24: R-SMU SETBACK AND BUILDING SEPARATION STANDARDS FOR MAIN BUILDINGS WITH DWELLING UNITS OR GROUP LIVING ACCOMMODATIONS OR LOCATED NORTH OF DURANT AVENUE

| | STANDARDS BY BUILDING STORY | | | | | SUPPLEMENTAL STANDARDS |
|---|-----------------------------|-----------------|-----------------|-----------------|---------------------|---|
| | 1 ST | 2 ND | 3 RD | 4 TH | 5 TH [1] | |
| Lot Line Setbacks, Minimum | | | | | | 23.304.030– Setbacks |
| Front | 10 ft. | 10 ft. | 10 ft. | 10 ft. | 10 ft. | |
| Rear | 10 ft. | 10 ft. | 10 ft. | 17 ft. | 19 ft. | |
| Interior | 4 ft. | 4 ft. | 6 ft. | 8 ft. | 10 ft. | |
| Street Side | 6 ft. | 8 ft. | 10 ft. | 10 ft. | 10 ft. | |
| Building Separation, Minimum | 8 ft. | 12 ft. | 16 ft. | 20 ft. | 24 ft. | 23.304.040– Building Separation in Residential Districts |
| [1] The 5 th story regulations are not applicable to buildings with less than 50% residential floor area nor for buildings outside of Subareas 1 and 2 (even if located north of Durant Avenue). | | | | | | |

TABLE 23.202-25: R-SMU LOT COVERAGE STANDARDS FOR MAIN BUILDINGS WITH DWELLING UNITS OR GROUP LIVING ACCOMMODATIONS OR LOCATED NORTH OF DURANT AVENUE

| | STANDARD BASED ON BUILDING HEIGHT | | | | | SUPPLEMENTAL STANDARDS |
|-----------------------|-----------------------------------|-----------|-----------|-----------|-----------|------------------------|
| | 1 STORY | 2 STORIES | 3 STORIES | 4 STORIES | 5 STORIES | |
| Lot Coverage, Maximum | | | | | | 23.304.120– |

| | | | | | | |
|---------------------------|-----|-----|-----|-----|-----|--------------|
| Interior and Through Lots | 55% | 55% | 50% | 45% | 40% | Lot Coverage |
| Corner Lots | 60% | 60% | 55% | 50% | 45% | |

d. Table 23.202-26 and Table 23.202-27 show setback, building separation, and lot coverage standards that apply to main buildings:

- i. Without dwelling units or group living accommodations: or
- ii. Located south of Durant Avenue.

TABLE 23.202-26: R-SMU SETBACK AND BUILDING SEPARATION STANDARDS FOR MAIN BUILDINGS WITHOUT DWELLING UNITS OR GROUP LIVING ACCOMMODATIONS OR LOCATED SOUTH OF DURANT AVENUE

| | BUILDING STORY STANDARD | | | | SUPPLEMENTAL STANDARDS |
|------------------------------|-------------------------|-----------------|-----------------|-----------------|---|
| | 1 ST | 2 ND | 3 RD | 4 TH | |
| Lot Line Setback, Minimum | | | | | |
| Front | 15 ft. | 15 ft. | 15 ft. | 15 ft. | 23.304.030– Setbacks |
| Rear | 15 ft. | 15 ft. | 15 ft. | 17 ft. | |
| Interior | 4 ft. | 4 ft. | 6 ft. | 8 ft. | |
| Street Side | 6 ft. | 8 ft. | 10 ft. | 10 ft. | |
| Building Separation, Minimum | 8 ft. | 12 ft. | 16 ft. | 20 ft. | 23.304.040– Building Separation in Residential Districts |

TABLE 23.202-27: R-SMU LOT COVERAGE STANDARDS FOR MAIN BUILDINGS WITHOUT DWELLING UNITS OR GROUP LIVING ACCOMMODATIONS OR LOCATED SOUTH OF DURANT AVENUE

| | STANDARD BASED ON BUILDING HEIGHT | | | | SUPPLEMENTAL STANDARDS |
|--------------------------|-----------------------------------|-----------|-----------|-----------|-----------------------------|
| | 1 STORY | 2 STORIES | 3 STORIES | 4 STORIES | |
| Lot Coverage, Maximum | | | | | |
| Interior and Through Lot | 45% | 50% | 40% | 35% | 23.304.120– Lot Coverage |
| Corner Lot | 50% | 50% | 45% | 40% | |

5. Increase in Lot Coverage.

- a. An AUP may be approve to increase lot coverage up to 100 percent for a main building that contains dwelling units, contains group living accommodations, or is located north of Durant Avenue.
- b. To approve an AUP, a finding must be made that the increase is appropriate given the setbacks and architectural design of surrounding buildings.

23.204 COMMERCIAL DISTRICTS

Sections:

- 23.204.010– Chapter Purpose
- 23.204.020– Allowed Land Uses
- 23.204.030– Additional Permit Requirements
- 23.204.040– Use-Specific Permit Requirements and Regulations
- 23.204.050– C-C Corridor Commercial District
- 23.204.060– C-U University Commercial District
- 23.204.070– C-N Neighborhood Commercial District
- 23.204.080– C-E Elmwood Commercial District
- 23.204.090– C-NS North Shattuck Commercial District
- 23.204.100– C-SA South Area Commercial District
- 23.204.110– C-T Telegraph Avenue Commercial District
- 23.204.120– C-SO Solano Avenue Commercial District
- 23.204.130– C-DMU Downtown Mixed-Use District
- 23.204.140– C-W West Berkeley Commercial District
- 23.204.150– C-AC Adeline Corridor Commercial District

23.204.010 – Chapter Purpose

This chapter identifies allowed land uses, permit requirements, and development standards for the Commercial Districts.

23.204.020 – Allowed Land Uses

- A. **Allowed Land Use Table.** Table 23.204-1: Allowed Uses in the Commercial Districts identifies allowed land uses and required permits in the Commercial Districts. All land uses are defined in Chapter 23.502 (Glossary). Permit requirements are described in Chapter 23.406 (Specific Permit Requirements). Permits required for land uses shown in Table 23.204-1 apply to both:
1. The initial establishment of a land use in a new building; and
 2. The change of use in an existing building or portion of a building.

TABLE 23.204-1: ALLOWED USES IN THE COMMERCIAL DISTRICTS

| ZC = Zoning Certificate AUP = Administrative Use Permit UP(PH) = Use Permit NP = Not Permitted -- = Permitted with AUP, see 23.204.030(B) [#] = Table Note Permit Requirement * Use-Specific Regulations Apply | COMMERCIAL DISTRICTS | | | | | | | | | | | USE-SPECIFIC REGULATIONS |
|---|-------------------------------------|-------------|--------|--------|--------|-------------|--------|--------|--------|------------------------|--------|-----------------------------------|
| | C-C | C-U | C-N | C-E | C-NS | C-SA | C-T | C-SO | C-DMU | C-W | C-AC | |
| Residential Uses | | | | | | | | | | | | |
| Accessory Dwelling Unit | See 23.306—Accessory Dwelling Units | | | | | | | | | | | |
| Dwellings | | | | | | | | | | | | |
| Single-Family | UP(PH) | UP(PH) * | UP(PH) | UP(PH) | UP(PH) | UP(PH) | UP(PH) | UP(PH) | UP(PH) | UP(PH) | UP(PH) | 23.204.060.B.3 |
| Two-Family | UP(PH) | UP(PH) * | UP(PH) | UP(PH) | UP(PH) | UP(PH) | UP(PH) | UP(PH) | UP(PH) | UP(PH) | UP(PH) | 23.204.060.B.3 |
| Multi-Family | UP(PH) | UP(PH) * | UP(PH) | UP(PH) | UP(PH) | UP(PH) | UP(PH) | UP(PH) | UP(PH) | UP(PH) | UP(PH) | 23.204.060.B.3 |
| Group Living Accommodation | UP(PH) | UP(PH) * | UP(PH) | UP(PH) | UP(PH) | UP(PH) | UP(PH) | UP(PH) | UP(PH) | UP(PH) | UP(PH) | 23.204.060.B.3 |
| Hotel, Residential | UP(PH) | UP(PH) * | UP(PH) | UP(PH) | UP(PH) | UP(PH) | UP(PH) | UP(PH) | UP(PH) | UP(PH) | UP(PH) | 23.204.060.B.3 |
| Mixed-Use Residential | UP(PH) | UP(PH) * | UP(PH) | UP(PH) | UP(PH) | UP(PH) * | UP(PH) | UP(PH) | UP(PH) | See Table 23.204-41 | UP(PH) | 23.204.060.B.3; 23.204.100.B.4 |
| Senior Congregate Housing | See 23.302.070.H | | | | | | | | | | | |
| Public and Quasi-Public Uses | | | | | | | | | | | | |
| Child Care Center | UP(PH) | UP(PH) | UP(PH) | UP(PH) | UP(PH) | UP(PH) | UP(PH) | UP(PH) | UP(PH) | UP(PH) | UP(PH) | |
| Cemetery/Crematory/Mausoleum | NP | NP | NP | NP | NP | NP | NP | NP | NP | NP | NP | |
| Club/Lodge | UP(PH) | UP(PH) | UP(PH) | UP(PH) | NP | UP(PH) | UP(PH) | NP | UP(PH) | UP(PH) | UP(PH) | |
| Columbaria | See 23.302.070.C | | | | | | | | | | | |

| ZC = Zoning Certificate AUP = Administrative Use Permit UP(PH) = Use Permit NP = Not Permitted -- = Permitted with AUP, see 23.204.030(B) [#] = Table Note Permit Requirement * Use-Specific Regulations Apply | COMMERCIAL DISTRICTS | | | | | | | | | | | USE-SPECIFIC REGULATIONS |
|---|----------------------|--------|--------|--------|--------|--------|--------|--------|--------|--------|--------|--------------------------|
| | C-C | C-U | C-N | C-E | C-NS | C-SA | C-T | C-SO | C-DMU | C-W | C-AC | |
| Community Care Facility | AUP | AUP | AUP | AUP | AUP | AUP | AUP | AUP | AUP | ZC | AUP | |
| Community Center | UP(PH) | UP(PH) | UP(PH) | UP(PH) | UP(PH) | UP(PH) | UP(PH) | UP(PH) | UP(PH) | UP(PH) | UP(PH) | |
| Emergency Shelter | See 0 | | - | - | See 0 | | | | | | | |
| Family Day Care Home, Large | ZC | ZC | ZC | ZC | ZC | ZC | ZC | ZC | ZC | ZC | ZC | |
| Family Day Care Home, Small | ZC | ZC | ZC | ZC | ZC | ZC | ZC | ZC | ZC | ZC | ZC | |
| Hospital | UP(PH) | UP(PH) | NP | NP | NP | NP | NP | NP | UP(PH) | UP(PH) | NP | |
| Library | UP(PH) | UP(PH) | UP(PH) | UP(PH) | UP(PH) | UP(PH) | UP(PH) | UP(PH) | UP(PH) | UP(PH) | UP(PH) | |
| Mortuaries and Crematories | UP(PH) | UP(PH) | NP | NP | NP | NP | NP | NP | NP | UP(PH) | NP | |
| Municipal Animal Shelter | - | - | - | - | - | - | - | - | - | - | -- | |
| Nursing Home | UP(PH) | UP(PH) | UP(PH) | UP(PH) | UP(PH) | UP(PH) | UP(PH) | UP(PH) | UP(PH) | UP(PH) | UP(PH) | |
| Park/Playground | ZC | ZC | ZC | ZC | ZC | ZC | ZC | ZC | ZC | AUP | ZC | |
| Public Safety and Emergency Service | UP(PH) | UP(PH) | UP(PH) | UP(PH) | UP(PH) | UP(PH) | UP(PH) | UP(PH) | UP(PH) | UP(PH) | UP(PH) | |
| Public Utility Substation/Tank | UP(PH) | UP(PH) | UP(PH) | UP(PH) | UP(PH) | UP(PH) | UP(PH) | UP(PH) | UP(PH) | UP(PH) | UP(PH) | |
| Religious Assembly | UP(PH) | UP(PH) | UP(PH) | UP(PH) | UP(PH) | UP(PH) | UP(PH) | UP(PH) | UP(PH) | AUP | UP(PH) | |
| School | UP(PH) | UP(PH) | UP(PH) | UP(PH) | UP(PH) | UP(PH) | UP(PH) | UP(PH) | UP(PH) | UP(PH) | UP(PH) | |

| ZC = Zoning Certificate AUP = Administrative Use Permit UP(PH) = Use Permit NP = Not Permitted -- = Permitted with AUP, see 23.204.030(B) [#] = Table Note Permit Requirement * Use-Specific Regulations Apply | COMMERCIAL DISTRICTS | | | | | | | | | | | USE-SPECIFIC REGULATIONS | |
|---|----------------------|-------------|-------------|---------|-------------|-------------|-------------|-------------|-------------|-------------|-------------|--|--|
| | C-C | C-U | C-N | C-E | C-NS | C-SA | C-T | C-SO | C-DMU | C-W | C-AC | | |
| School, Vocational | AUP | AUP | AUP | AUP | AUP | AUP | AUP | AUP | AUP | AUP | UP(PH) | AUP | |
| Retail Uses | | | | | | | | | | | | | |
| Alcoholic Beverage Retail Sale | UP(PH) * | UP(PH) * | UP(PH) * | UP(PH)* | UP(PH) * | UP(PH) * | NP | UP(PH) * | UP(PH) * | UP(PH) * | UP(PH) * | 23.204.060.B.2; 23.310 | |
| Cannabis Retailer | ZC* | ZC* | ZC* | ZC* | ZC* | ZC* | ZC* | ZC* | ZC* | ZC* | ZC* | 23.320; 12.21; and 12.22 | |
| Cannabis Retailer, Delivery Only | ZC* | ZC* | ZC* | ZC* | ZC* | ZC* | ZC* | ZC* | ZC* | ZC* | -- | 23.320; 12.21; and 12.22 | |
| Firearm/Munitions Business | UP(PH) * | UP(PH) * | UP(PH) * | UP(PH)* | UP(PH) * | UP(PH) * | UP(PH) * | UP(PH) * | NP | UP(PH) | UP(PH) * | 23.302.070.D | |
| Industrial and Mining Products | - | - | - | - | - | - | - | - | - | - | -- | | |
| Pawn Shop/Auction House | UP(PH) | - | NP | NP | NP | NP | NP | NP | UP(PH) | UP(PH) | NP | | |
| Pet Store | UP(PH) | UP(PH) | UP(PH) | UP(PH) | UP(PH) | UP(PH) | UP(PH) | UP(PH) | UP(PH) | ZC [3] | UP(PH) | | |
| Retail, General | ZC [1] | ZC [1] | ZC* [2] | ZC* [2] | ZC* [2] | ZC [1] | ZC | ZC* [2] | ZC | ZC* [3] | ZC* | 23.204.040.E (for department stores) 23.204.040.F (for drug stores) | |
| Smoke Shop | UP(PH) * | UP(PH) * | UP(PH) * | UP(PH)* | UP(PH) * | UP(PH) * | UP(PH) * | UP(PH) * | NP | UP(PH) * | UP(PH) * | 23.302.070.I | |
| Personal and Household Service Uses | | | | | | | | | | | | | |
| Personal and Household Services, | ZC [1] | ZC [1] | ZC [2] | ZC [2] | ZC [2] | ZC [1] | ZC | ZC [2] | ZC | ZC [5] | ZC | | |

| ZC = Zoning Certificate AUP = Administrative Use Permit UP(PH) = Use Permit NP = Not Permitted -- = Permitted with AUP, see 23.204.030(B) [#] = Table Note Permit Requirement * Use-Specific Regulations Apply | COMMERCIAL DISTRICTS | | | | | | | | | | | USE-SPECIFIC REGULATIONS |
|---|----------------------|-------------|---------|---------|---------|-------------|-------------|---------|--------|-------------|--------|--|
| | C-C | C-U | C-N | C-E | C-NS | C-SA | C-T | C-SO | C-DMU | C-W | C-AC | |
| General | | | | | | | | | | | | |
| Kennels and Pet Boarding | NP | NP | NP | NP | NP | NP | NP | NP | NP | UP(PH) | NP | |
| Laundromats and Cleaners | AUP | AUP | UP(PH) | UP(PH) | UP(PH) | AUP | AUP | UP(PH) | UP(PH) | AUP [4] | AUP | |
| Veterinary Clinic | UP(PH) | UP(PH) | UP(PH) | UP(PH) | UP(PH) | UP(PH) | UP(PH) | UP(PH) | UP(PH) | UP(PH) | UP(PH) | |
| Video Tape/Disk Rental | ZC [1] | ZC [1] | ZC [2] | AUP | ZC [2] | - | ZC | ZC [2] | ZC | ZC [5] | NP | |
| Office Uses | | | | | | | | | | | | |
| Business Support Services | ZC [1] | ZC [1] | ZC [2] | ZC [2] | ZC [2] | ZC [1] | ZC* | ZC [2] | ZC | ZC [5] | ZC [6] | 23.204.110.B.6 |
| Banks and Financial Services, Retail | AUP | AUP | UP(PH) | UP(PH) | UP(PH) | ZC [1] | AUP* | UP(PH) | ZC* | AUP | ZC | 23.204.110.B.6; 23.204.130.B.3; 23.204.130.D.3 |
| Insurance Agents, Title Companies, Real Estate Agents, Travel Agents | ZC [1] | ZC [1] | ZC* [2] | ZC* [2] | ZC* [2] | ZC [1] | ZC* | ZC* [2] | ZC* | ZC [5] | ZC [6] | 23.204.040.D;23.204.110.B.6; 23.204.130.D.3 |
| Medical Practitioners | ZC [1] | ZC [1] | AUP | NP | UP(PH) | ZC [1] | AUP* | UP(PH) | ZC* | ZC [5] | ZC [6] | 23.204.040.D; 23.204.110.B.6; 23.204.130.D.3 |
| Non-Chartered Financial Institutions | UP(PH) * | UP(PH) * | NP | NP | NP | UP(PH) * | UP(PH) * | NP | NP | UP(PH) * | UP(PH) | 23.302.070.F 23.204.110.B.6 |
| Office, Business and Professional | ZC [1] | ZC [1] | AUP* | AUP* | AUP* | ZC [1] | AUP* | AUP* | ZC* | ZC [5] | ZC [6] | 23.204.040.B; 23.204.110.B.6; 23.204.130.D.3 |

| ZC = Zoning Certificate AUP = Administrative Use Permit UP(PH) = Use Permit NP = Not Permitted -- = Permitted with AUP, see 23.204.030(B) [#] = Table Note Permit Requirement * Use-Specific Regulations Apply | COMMERCIAL DISTRICTS | | | | | | | | | | | USE-SPECIFIC REGULATIONS |
|---|----------------------|-------------|-------------|--------|---------|-------------|-------------|--------|-------------|-------------|--------|--|
| | C-C | C-U | C-N | C-E | C-NS | C-SA | C-T | C-SO | C-DMU | C-W | C-AC | |
| Food and Alcohol Service, Lodging, Entertainment, and Assembly Uses | | | | | | | | | | | | |
| Adult-oriented Business | UP(PH) * | UP(PH) * | NP | NP | NP | NP | NP | NP | UP(PH) * | UP(PH) * | NP | 23.302.070.A |
| Amusement Device Arcade | UP(PH) * | UP(PH) * | NP | NP | NP | UP(PH) * | NP | NP | UP(PH) * | UP(PH) * | UP(PH) | 23.302.070.B |
| Bar/Cocktail Lounge/Tavern | UP(PH) * | UP(PH) * | UP(PH) * | - | NP | UP(PH) * | UP(PH) * | NP | UP(PH) * | UP(PH) * | UP(PH) | 23.204.100.B.3; 23.204.110.B.2; 23.310 |
| Commercial Recreation Center | See 23.204.040.A | | | | | | | | | | | |
| Dance/Exercise/Martial Arts/Music Studio | ZC [1] | ZC [1] | ZC [2] | AUP | AUP [4] | ZC [1] | ZC | AUP | ZC | ZC [7] | ZC | |
| Entertainment Establishment | UP(PH) | UP(PH) | UP(PH) | NP | UP(PH) | UP(PH) | UP(PH) | UP(PH) | UP(PH) | UP(PH) | UP(PH) | |
| Food Service Establishment | See 23.204.040.E | | | | | | | | | | | |
| Group Class Instruction | ZC [1] | ZC [1] | AUP | AUP | AUP* | ZC [1] | ZC* | AUP | ZC* | ZC | ZC | 23.204.040.B |
| Gym/Health Club | See 23.204.040.C | | | | | | | | | | | |
| Hotels, Tourist | UP(PH) | UP(PH) | UP(PH) | UP(PH) | UP(PH) | UP(PH) | UP(PH) | UP(PH) | UP(PH) | UP(PH) | UP(PH) | |
| Motels, Tourist | UP(PH) | UP(PH) | NP | NP | NP | NP | NP | NP | UP(PH) | UP(PH) | NP | |
| Theater | UP(PH) | UP(PH) | UP(PH) | UP(PH) | NP | UP(PH) | UP(PH) | NP | AUP | UP(PH) | UP(PH) | |

| ZC = Zoning Certificate AUP = Administrative Use Permit UP(PH) = Use Permit NP = Not Permitted -- = Permitted with AUP, see 23.204.030(B) [#] = Table Note Permit Requirement * Use-Specific Regulations Apply | COMMERCIAL DISTRICTS | | | | | | | | | | | USE-SPECIFIC REGULATIONS |
|---|----------------------|--------|--------|--------|--------|-------------|-----|--------|--------|-------------|--------|--|
| | C-C | C-U | C-N | C-E | C-NS | C-SA | C-T | C-SO | C-DMU | C-W | C-AC | |
| Vehicle Service and Sales Uses | | | | | | | | | | | | |
| Alternative Fuel Station | UP(PH) | UP(PH) | UP(PH) | NP | UP(PH) | UP(PH) | NP* | UP(PH) | NP | AUP* | UP(PH) | 23.204.110.B.4; 23.204.140.B.3 |
| Electric Vehicle Charging Station | AUP | AUP | AUP | AUP | AUP | AUP | AUP | AUP | AUP | AUP* | AUP | |
| Gasoline Fuel Stations | UP(PH) | UP(PH) | UP(PH) | NP | UP(PH) | UP(PH) | NP* | UP(PH) | NP | UP(PH) * | UP(PH) | 23.204.140.B.3 |
| Large Vehicle Sales and Rental | AUP | NP | NP | NP | NP | NP | NP | NP | NP | AUP* [8] | NP | 23.204.140.B.3 |
| Small Vehicle Sales and Service | AUP | NP | NP | NP | NP | UP(PH) * | NP | NP | UP(PH) | UP(PH) * | NP | 23.204.100.B.5; 23.204.140.B.3 |
| Tire Sales and Service | UP(PH) | NP | NP | NP | NP | NP | NP | NP | NP | UP(PH) * | NP | 23.204.140.B.3 |
| Vehicle Parts Store | ZC [1] | NP | ZC [2] | ZC [2] | ZC [2] | ZC [1] | ZC | ZC [2] | NP | AUP* [8] | ZC | |
| Vehicle Rentals | AUP | NP | NP | NP | NP | NP | NP | NP | UP(PH) | AUP* [8] | NP | 23.204.140.B.3 |
| Vehicle Repair and Service | AUP | NP | NP | NP | NP | NP | NP | NP | NP | AUP* [8] | NP | |
| Vehicle Sales, New | AUP | NP | NP | NP | NP | UP(PH) * | NP | NP | UP(PH) | AUP* [8] | NP | 23.204.140.B.3 |
| Vehicle Sales, Used | AUP | NP | NP | NP | NP | UP(PH) * | NP | NP | UP(PH) | UP(PH) * | NP | 23.204.100.B.5; 23.204.140.B.3; 23.204.140.D.4 |
| Vehicle Wash | UP(PH) | NP | NP | NP | NP | NP | NP | NP | NP | UP(PH) * | NP | 23.204.140.B.3 |
| Vehicle Wrecking | NP | NP | NP | NP | NP | NP | NP | NP | NP | NP | NP | |

| ZC = Zoning Certificate AUP = Administrative Use Permit UP(PH) = Use Permit NP = Not Permitted -- = Permitted with AUP, see 23.204.030(B) [#] = Table Note Permit Requirement * Use-Specific Regulations Apply | COMMERCIAL DISTRICTS | | | | | | | | | | | USE-SPECIFIC REGULATIONS |
|---|----------------------|--------|--------|--------|--------|--------|--------|--------|--------|---------|--------|--------------------------|
| | C-C | C-U | C-N | C-E | C-NS | C-SA | C-T | C-SO | C-DMU | C-W | C-AC | |
| Industrial and Heavy Commercial Uses | | | | | | | | | | | | |
| Bus/Cab/Truck/Public Utility Depot | - | - | - | - | - | - | - | - | - | - | -- | |
| Commercial Excavation | UP(PH) | UP(PH) | UP(PH) | UP(PH) | UP(PH) | UP(PH) | UP(PH) | UP(PH) | - | NP | UP(PH) | |
| Contractors Yard | - | - | - | - | - | - | - | - | - | AUP | -- | |
| Dry Cleaning and Laundry Plant | UP(PH) | UP(PH) | NP | - | UP(PH) | NP | NP | NP | UP(PH) | NP | NP | |
| Laboratory | | | | | | | | | | | | |
| Commercial Physical or Biological | AUP | AUP | NP | NP | NP | NP | NP | NP | AUP | NP | NP | |
| Cannabis Testing | AUP | AUP | NP | NP | NP | NP | NP | NP | AUP | AUP [9] | NP | |
| Manufacturing | | | | | | | | | | | | |
| Construction Products | - | - | - | - | | - | - | - | - | UP(PH) | -- | |
| Light Manufacturing | - | - | - | - | | - | - | - | - | AUP [8] | -- | |
| Pesticides/Herbicides /Fertilizers | - | - | - | - | | - | - | - | - | UP(PH) | -- | |
| Petroleum Refining and Products | - | - | - | - | | - | - | - | - | UP(PH) | -- | |
| Pharmaceuticals | - | - | - | - | | - | - | - | - | UP(PH) | -- | |
| Primary Production Manufacturing | - | - | - | - | NP | - | - | - | - | UP(PH) | -- | |

| ZC = Zoning Certificate AUP = Administrative Use Permit UP(PH) = Use Permit NP = Not Permitted -- = Permitted with AUP, see 23.204.030(B) [#] = Table Note Permit Requirement * Use-Specific Regulations Apply | COMMERCIAL DISTRICTS | | | | | | | | | | | USE-SPECIFIC REGULATIONS |
|---|----------------------|--------|--------|--------|--------|--------|--------|--------|-------------|---------|--------|--------------------------|
| | C-C | C-U | C-N | C-E | C-NS | C-SA | C-T | C-SO | C-DMU | C-W | C-AC | |
| Semiconductors | - | - | - | - | NP | - | - | - | - | UP(PH) | -- | |
| Material Recovery Enterprise | - | - | - | - | - | - | - | - | - | - | -- | |
| Media Production | UP(PH) | UP(PH) | UP(PH) | UP(PH) | UP(PH) | UP(PH) | UP(PH) | UP(PH) | UP(PH) * | AUP | UP(PH) | 23.204.130.B.4 |
| Mini-storage | UP(PH) | NP | NP | NP | NP | NP | NP | - | UP(PH) | NP | NP | |
| Recycled Materials Processing | - | - | - | - | - | - | - | - | - | - | -- | |
| Recycling Redemption Center | AUP | AUP | AUP | AUP | AUP | AUP | AUP | AUP | AUP | AUP | AUP | |
| Repair Service, Non-Vehicle | - | - | - | - | - | - | - | - | - | AUP | -- | |
| Research and Development | - | - | - | - | - | - | - | - | - | AUP | -- | |
| Services to Buildings and Dwellings | - | - | - | - | - | - | - | - | - | AUP | -- | |
| Warehouse | UP(PH) | NP | NP | NP | NP | NP | NP | - | UP(PH) | NP | NP | |
| Warehouse-Based Non-Store Retailer | - | - | - | - | - | - | - | - | - | - | -- | |
| Wholesale Trade | - | - | - | - | -- | - | - | - | - | AUP [8] | -- | |
| Incidental Uses | | | | | | | | | | | | |
| Amusement Devices | AUP* | AUP* | AUP* | AUP* | AUP* | AUP* | AUP* | AUP* | AUP* | AUP* | UP(PH) | 23.302.070.B |
| Alcoholic Beverage | See 23.310 | | | | | | | | | | | |

| ZC = Zoning Certificate AUP = Administrative Use Permit UP(PH) = Use Permit NP = Not Permitted -- = Permitted with AUP, see 23.204.030(B) [#] = Table Note Permit Requirement * Use-Specific Regulations Apply | COMMERCIAL DISTRICTS | | | | | | | | | | | USE-SPECIFIC REGULATIONS |
|---|----------------------|--------|-------------|---------|--------|--------|--------|--------|-------------|--------|--------|--------------------------|
| | C-C | C-U | C-N | C-E | C-NS | C-SA | C-T | C-SO | C-DMU | C-W | C-AC | |
| Service | | | | | | | | | | | | |
| Cafeteria, On-Site | UP(PH) | UP(PH) | UP(PH) | UP(PH) | UP(PH) | UP(PH) | UP(PH) | UP(PH) | UP(PH) | AUP | UP(PH) | |
| Columbaria | See 23.302.070.C | | | | | | | | | | | |
| Food and Beverage for Immediate Consumption | ZC | ZC | AUP | UP(PH) | UP(PH) | ZC | AUP | UP(PH) | ZC | ZC | ZC | |
| Food Service Establishment | See 23.302.070.E | | | | | | | | | | | |
| Live Entertainment | See 23.302.020.D | | | | | | | | | | | |
| Manufacturing | AUP | AUP | UP(PH) | UP(PH) | NP | UP(PH) | AUP | AUP | AUP | AUP | AUP | |
| Retail Sale of Goods Manufactured On-Site | ZC [1] | ZC [1] | ZC [2] | ZC [2] | ZC [2] | ZC [1] | ZC | ZC [2] | ZC | AUP | ZC | |
| Storage of Goods (>25% gross floor area) | AUP* | AUP* | AUP* | AUP* | AUP* | AUP* | AUP* | AUP* | AUP* | AUP* | AUP | 23.302.020.C |
| Wholesale Activities | AUP* | AUP* | UP(PH) * | UP(PH)* | NP | AUP* | AUP* | AUP* | AUP* | AUP | AUP | 23.204.080.B.3 |
| Other Miscellaneous Uses | | | | | | | | | | | | |
| Art/Craft Studio | AUP | AUP | AUP | AUP | AUP | AUP | AUP | AUP | AUP | AUP | ZC [6] | |
| ATM, Exterior and Attached to Bank | AUP | AUP | AUP | UP(PH) | AUP | AUP | AUP | AUP* | AUP | AUP | AUP | 23.204.120.B.2 |
| ATM, Interior or Exterior and Not With Bank | UP(PH) | UP(PH) | UP(PH) | NP | UP(PH) | UP(PH) | UP(PH) | NP | UP(PH) * | AUP | UP(PH) | 23.204.130.B.2 |
| Circus/Carnival | UP(PH) | UP(PH) | UP(PH) | UP(PH) | UP(PH) | UP(PH) | UP(PH) | UP(PH) | UP(PH) | UP(PH) | UP(PH) | |
| Drive-in Uses | UP(PH) | NP | NP | NP | UP(PH) | UP(PH) | NP | UP(PH) | NP | NP | UP(PH) | |

| ZC = Zoning Certificate AUP = Administrative Use Permit UP(PH) = Use Permit NP = Not Permitted -- = Permitted with AUP, see 23.204.030(B) [#] = Table Note Permit Requirement * Use-Specific Regulations Apply | COMMERCIAL DISTRICTS | | | | | | | | | | | USE-SPECIFIC REGULATIONS |
|---|--|------|------|------|------|------|------|------|-------|---------|------|--------------------------|
| | C-C | C-U | C-N | C-E | C-NS | C-SA | C-T | C-SO | C-DMU | C-W | C-AC | |
| Home Occupations | See 23.302.040 | | | | | | | | | | | |
| Live/Work | See 23.312 | | | | | | | | | | | |
| Parking Lot/Structure | See 23.302.070.G | | | | | | | | | | | |
| Public Market, Open Air | AUP | AUP | AUP | AUP | AUP | AUP | AUP | AUP | AUP | UP(PH) | AUP | |
| Public Market, Enclosed | AUP | AUP | AUP | AUP | AUP | AUP | AUP | AUP | AUP | AUP [9] | AUP | |
| Short-Term Rental | See 23.314 | | | | | | | | | | | |
| Urban Agriculture, Low-Impact | ZC* | ZC* | ZC* | ZC* | ZC* | ZC* | ZC* | ZC* | ZC* | ZC | ZC | 23.318 |
| Urban Agriculture, High-Impact | AUP* | AUP* | AUP* | AUP* | AUP* | AUP* | AUP* | AUP* | AUP* | AUP | AUP | 23.318 |
| Wireless Telecommunication Facility | See 23.332—Wireless Communication Facilities | | | | | | | | | | | |
| Notes: [1] Change of use of floor area over 3,000 square feet requires an AUP. [2] Change of use of floor area over 2,000 square feet requires an AUP. [3] Requires an AUP for uses 3,500 sq. ft. to 7,500 square feet. Requires a Use Permit for uses more than 7,500 sq. ft. [4] Requires a Use Permit if 5,000 sq. ft. or more. [5] Requires an AUP for uses 3,000 sq. ft. to 5,000 square feet. Requires a Use Permit for uses more than 5,000 sq. ft. [6] Requires an AUP for uses 2,500 sq. ft. or greater or 50 ft. wide or greater on Shattuck, between Ward and Russell; Adeline between Russell and the City boundary; on Ashby, east of Adeline; or on the north side of Ashby, west of Adeline. [7] Requires a Use Permit if 7,500 square feet or more. [8] Require a Use Permit if either 5,000 sq. ft. or more of floor area or 10,000 square feet or more of lot area. [9] Requires a Use Permit if more than 10,000 sq. ft. | | | | | | | | | | | | |

Unlisted Land Uses. Any use not listed in Table 23.204-1: Allowed Uses in the Commercial Districts is permitted with an AUP. To approve the AUP, the Zoning Officer must find that the use is compatible with the purposes of the district where it is located. Any use found to be incompatible with the purposes of the district is not permitted.

B. Use-Specific Regulations. Uses subject to supplemental regulations are shown in Table 23.204-1: Allowed Uses in the Commercial Districts with an asterisk (*) following the permit requirement (e.g., ZC*). The Use-Specific Regulations column in Table 23.204-1 identifies the location of these regulations in the Zoning Ordinance.

23.204.030 – Additional Permit Requirements

A. Change of Use.

1. Uses subject to additional permit requirements with a change of use are shown in Table 23.204-1: Allowed Uses in the Commercial Districts with a note [1] or [2] following the permit requirement (e.g., ZC [1]).
2. A change of use means a change to a different category of commercial or manufacturing use but does not include changes between uses that are classified in the same category of commercial or manufacturing use. For example, changing a pet store (in “Retail Use” category) to a medical practitioner (in “Offices” category) is subject to change of use permit requirements in Table 23.204-1. Changing a pet store to general retail (also in “Retail Use” category) is not subject to the change of use permit requirements.

B. New Floor Area.

1. **When Permit is Required.** A project that creates new floor area for any use requires permits as shown in Table 23.204-2: New Floor Area Permit Requirements. Creation of new floor area includes:
 - a. Construction of new main buildings or accessory buildings;
 - b. Additions to existing buildings; or
 - c. The installation of new floor or mezzanine levels within or onto existing buildings.

TABLE 23.204-2: NEW FLOOR AREA PERMIT REQUIREMENTS

| DISTRICT/NEW GROSS FLOOR AREA | PERMIT REQUIRED FOR NEW FLOOR AREA |
|--|------------------------------------|
| C-C, C-U | |
| Less than 5,000 sq. ft. | ZC |
| 5,000 sq. ft. or more | UP(PH) |
| C-N, C-E, C-SO (any amount of new floor area) | UP(PH) |
| C-NS | |
| Less than 2,000 sq. ft. | ZC |
| 2,000 sq. ft. or more | UP(PH) |
| C-SA | |
| Less than 3,000 sq. ft. | ZC |
| 3,000 sq. ft. or more | UP(PH) |
| C-T | - |
| Less than 1,500 sq. ft. | AUP |
| 1,500 sq. ft. or more | UP(PH) |
| C-DMU | |
| Less than 10,000 sq. ft. | ZC |
| 10,000 sq. ft. or more | UP(PH) |
| C-W | |
| 5,000 sq. ft. or more except when an AUP is required below | UP(PH) |
| 7,500 sq. ft. or less in a building containing only retail uses | AUP |
| 20,000 sq. ft. or less in a building with residential and retail space that is more than 15% and less than 33% of the floor area being created | AUP |
| C-AC | |
| New Main Building or New Dwelling Unit | UP(PH) |
| Addition of 5,000 sq ft or more | UP(PH) |

2. **C-DMU Findings.** To approve a Use Permit for new floor area in the C-DMU district, the ZAB must find that:

- a. The addition or new building is compatible with the visual character and form of the district; and

- b. No designated landmark structure, structure of merit, or historic district in the vicinity would be adversely affected by the appearance or design of the proposed addition.
- 3. **C-W Findings.** To approve an AUP or Use Permit for new floor area in the C-W district, the review authority must find that the new use or structure provides an intensity of development which does not underutilize the property.
- 4. **C-AC Findings.** To approve a Use Permit for new floor area in the C-AC district, the review authority must find that the proposed use or structure will:
 - a. Be compatible with the purposes of the District;
 - b. Be compatible with the design and character within the District and the adjacent residential neighborhoods;
 - c. Encourage utilization of public transit and off-street parking facilities in the area of the proposed building; and
 - d. If a new residential development, that the proposed use or structure facilitates construction of affordable housing as defined by the US Department of Housing and Urban Development (HUD) Guidelines.

C. Tenant Space Reconfiguration.

- 1. Reconfiguration of tenant space in an existing building requires a permit as listed in Table 23.204-3: Tenant Space Reconfiguration Permit Requirements.
- 2. As used in this section, tenant reconfiguration means any physical change to an existing building’s walls separating leased spaces so as to change:
 - a. The number of lease spaces for commercial businesses; or
 - b. The square footage of leasable floor area of an existing commercial lease space.

TABLE 23.204-3: TENANT SPACE RECONFIGURATION PERMIT REQUIREMENTS

| District | Permit Required for Tenant Space Reconfiguration Project |
|---|--|
| C-C, C-U | |
| Less than 5,000 sq. ft. | ZC |
| 5,000 sq. ft. or greater | AUP |
| C-N, C-E, C-NS, C-SO (All reconfiguration projects) | AUP |
| C-SA, C-DMU, C-AC | No additional permit required |

| | |
|---|-----|
| C-T | |
| Increasing the number of individual tenant spaces | ZC |
| 5,000 sq. ft. or greater | AUP |
| Creating a tenant space less than 1,000 sq. ft. | AUP |
| C-W | |
| Less than 5,000 sq. ft | ZC |
| In existing buildings in a designated node affecting 5,000 sq. ft. or greater | AUP |

D. Major Residential Additions.

1. Where Allowed/Required Permits.

- a. Major residential additions in the C-W district require an AUP.
- b. No additional permits are required for major residential additions in all other C districts.

- 2. Findings.** To deny an AUP for a major residential addition in the C-W district, the review authority must find that although the proposed major residential addition satisfies all other standards of the Zoning Ordinance, the addition would unreasonably obstruct sunlight, air, or views.

E. Changes to Nonconforming Structures. See Section 23.324.050– Nonconforming Structures and Buildings for permits required to modify structures that do not conform to setback, height, and other development standards.

F. Accessory Structures. For accessory structure permit requirements, see the following:

- 1. Section 23.304.060– Accessory Buildings and Enclosed Accessory Structures.
- 2. Section 23.304.070– Unenclosed Accessory Structures in Residential Districts.
- 3. Section 23.304.080– Fences.

23.204.040 – Use-Specific Permit Requirements and Regulations

A. Commercial Recreation Centers. See Table 23.204-4: Commercial Recreation Center Permit Requirements for commercial recreation centers in the Commercial Districts.

TABLE 23.204-4: COMMERCIAL RECREATION CENTER PERMIT REQUIREMENTS

| DISTRICT/USE SIZE | PERMIT REQUIRED |
|---|-----------------|
| C-C, C-U, C-T, C-DMU, C-W | |
| Under 5,000 sq. ft indoor use | ZC |
| 5,000 to 10,000 sq. ft. indoor use | AUP |
| Over 10,000 sq. ft. indoor use or outdoor use of any size | UP(PH) |
| C-N, C-E, C-NS, C-SA, C-SO, C-AC | |
| Under 3,000 sq. ft indoor use | AUP |
| Over 3,000 sq. ft. indoor use or outdoor use of any size | UP(PH) |

B. Group Class Instruction.

- C-NS and C-DMU Districts.** When group class instruction in the C-NS or C-DMU districts are located on the ground floor adjacent to a street frontage, storefront windows must include a window display or to be transparent and provide pedestrian viewing at least 10 feet into the storefront area.
- C-NS District.** Group class instruction uses in the C-NS may not exceed 2,500 square feet.
- C-T District.** Group class instruction uses in the C-T district are not permitted on the ground floor.

C. Gyms and Health Clubs.

- Permits Required.** Table 23.204-5: Gym and Health Club Permit Requirements shows permits required for gyms and health clubs in the Commercial Districts.

TABLE 23.204-5: GYM AND HEALTH CLUB PERMIT REQUIREMENTS

| DISTRICT/USE SIZE | PERMIT REQUIRED [1] |
|---------------------------|---------------------|
| C-C, C-U, C-DMU | |
| Under 7,500 sq. ft | ZC |
| 7,500 sq. ft. and greater | AUP |
| C-N, C-E, C-NS, C-SO | AUP |
| C-SA, C-T, C-AC | ZC |
| C-W | |
| Under 7,500 sq. ft | ZC |

| | |
|---|--------|
| 7,500 sq. ft. and greater | UP(PH) |
| <p>Note: [1] Change of use permit requirements as described in Section – Additional Permit Requirements. A (Change of Use) also apply. In the C-C, C-U, and C-SA districts, a change of use of gross floor area over 3,000 square feet requires an AUP. In the C-N, C-E, C-NS, and C-SO districts, a change of use of gross floor area over 2,000 square feet requires an AUP.</p> | |

2. **C-DMU District.** When located on the ground floor adjacent to a street frontage, storefront windows for a gym and health club in the C-DMU district must include a window display or to be transparent and provide pedestrian viewing at least 10 feet into the storefront area.

D. Transparency Requirement for Office Uses. When office uses shown in are located on the ground floor adjacent to a street frontage, storefront windows shall either:

1. Include a storefront window display; or
2. Be transparent and provide pedestrian viewing at least 10 feet into the storefront area.

TABLE 23.204-6: OFFICE USES SUBJECT TO TRANSPARENCY REQUIREMENT

| OFFICE USE | DISTRICT |
|--|---------------------------------|
| Insurance Agents, Title Companies, Real Estate Agents, Travel Agents | CN, C-E, C-NS, CT, C-SO, C-DMU |
| Medical Practitioners | C-T |
| Office, Business and Professional | CN, C-E, C-NS, C-T, C-SO, C-DMU |

E. Department Stores. Table 23.204-7: Department Store Permit Requirements shows permits required for department stores in the Commercial Districts.

TABLE 23.204-7: DEPARTMENT STORE PERMIT REQUIREMENTS

| DISTRICT/USE SIZE | PERMIT REQUIRED [1] |
|-----------------------|---------------------|
| C-SA, C-T | |
| 3,000 sq. ft. or less | ZC |
| Over 3,000 sq. ft. | AUP |
| C-E, C-NS, C-SO | |

| | |
|---|---------------|
| 3,000 sq. ft. or less | ZC |
| Over 3,000 sq. ft. | Not Permitted |
| C-N | |
| 3,000 sq. ft. or less | AUP |
| Over 3,000 sq. ft. | Not Permitted |
| C-C, C-U | ZC |
| C-AC | |
| 3,000 sq ft or less | ZC |
| Over 3,000 sq ft | UP(PH) |
| <p>Note: [1] Change of use permit requirements as described in Section – Additional Permit Requirements. A (Change of Use) also apply. In the C-C, C-U, and C-SA districts, a change of use of gross floor area over 3,000 square feet requires an AUP. In the C-N, C-E, C-NS, and C-SO districts, a change of use of gross floor area over 2,000 square feet requires an AUP.</p> | |

F. **Drugstores.** The following requirements apply to drugstores in the C-N, CE, C-NS, and C-SO districts.

1. **Where Prohibited.** A new or expanded drugstore is not permitted if it is:
 - a. Over 5,000 square feet in gross floor area; and
 - b. Within 1,000 feet of any property containing an existing drugstore.
2. **Measurement of Distance.** Distances between drugstores are measured by a straight line from the nearest point of the property line of the parcel on which the drugstore is proposed to the nearest point of the lot line of the lot on which the nearest drugstore is located.

23.204.050 – C-C Corridor Commercial District

A. **District Purpose.** The purpose of the Corridor Commercial (C-C) district is to:

1. Implement the General Plan’s designations for Avenue Commercial areas;
2. Provide locations for a wide variety of activities along thoroughfares;
3. Encourage development in underutilized neighborhood and community shopping areas; and
4. Promote development compatible with adjacent commercial and residential areas.

B. Allowed Land Uses. See Table 23.204-1: Allowed Uses in the Commercial Districts.

C. Additional Permit Requirements. See Section 23.204.030– Additional Permit Requirements.

D. Development Standards.

1. **Basic Standards.** See Table 23.204-8: C-C Development Standards. For residential-only projects, see also Table 23.204-9: C-C Setbacks and Building Separation for Residential-Only Uses and Table 23.204-10: C-C Lot Coverage Standards for Residential-Only Uses.

2. **Lots Abutting or Confronting a Residential District.** See Section 23.304.130– Non-Residential Districts Abutting a Residential District for additional building feature requirements for lots that abut or confront a Residential District.

TABLE 23.204-8: C-C DEVELOPMENT STANDARDS

| | PROJECT LAND USE | | | SUPPLEMENTAL STANDARDS |
|---|----------------------|------------------------------|----------------------|------------------------|
| | NON-RESIDENTIAL | MIXED USE | RESIDENTIAL ONLY | |
| Lot Area Minimum | | | | 23.304.020 |
| New Lots | No minimum | | 5,000 sq. ft | |
| Per Group Living Accommodation Resident | 350 sq. ft. [1] | | | |
| Usable Open Space, Minimum | | | | 23.304.090 |
| Per Dwelling Unit | 200 sq. ft. | 200 sq. ft. [2] | 200 sq. ft. | |
| Per Group Living Accommodation Resident | 90 sq. ft. | | | |
| Floor Area Ratio, Maximum | 3.0 | | No maximum | |
| Main Building Height, Minimum | No minimum | | | |
| Main Building Height, Maximum | 40 ft. and 2 stories | 40 ft. and 3 stories [3] [4] | 35 ft. and 3 stories | 23.304.050 |
| Lot Line Setbacks, Minimum | | | | 23.304.030– Setbacks |

| | PROJECT LAND USE | | | SUPPLEMENTAL STANDARDS |
|---|--------------------|-----------|------------------|--|
| | NON-RESIDENTIAL | MIXED USE | RESIDENTIAL ONLY | |
| Abutting/Confronting a Non-residential District | No minimum | | | |
| Abutting/Confronting a Residential District | See 23.304.130.C.2 | | | |
| Building Separation, Minimum | No minimum | | | 23.304.040– Building Separation in Residential Districts |
| Lot Coverage, Maximum | 100% | | | 23.304.120– Lot Coverage |
| <p>Notes:</p> <p>[1] One additional resident is allowed for remaining lot area between 200 and 350 square feet.</p> <p>[2] Minimum open space for mixed use projects can be reduced with a UP(PH). See 23.204.050.D.3.</p> <p>[3] In mixed use buildings, the third and higher stories must be used for residential purposes.</p> <p>[4] The maximum height of a mixed use project can be increased to 50 ft and 4 stories with the issuance of a UP(PH).</p> | | | | |

TABLE 23.204-9: C-C SETBACKS AND BUILDING SEPARATION FOR RESIDENTIAL-ONLY USES

| | STANDARDS BY BUILDING STORY [1] | | | SUPPLEMENTAL STANDARDS |
|----------------------------|---------------------------------|-----------------|-----------------|------------------------|
| | 1 ST | 2 ND | 3 RD | |
| Lot Line Setbacks, Minimum | | | | 23.304.030– Setbacks |
| Front | 15 ft. | 15 ft. | 15 ft. | |
| Rear | 15 ft. | 15 ft. | 15 ft. | |
| Interior | 4 ft. | 4 ft. | 6 ft. | |

| | | | | |
|---|-------|--------|--------|--|
| Street Side | 6 ft. | 8 ft. | 10 ft. | |
| Building Separation, Minimum | 8 ft. | 12 ft. | 16 ft. | 23.304.040– Building Separation in Residential Districts |
| [1] Development standards included in this table may be modified with a UP(PH). See 23.204.050.D.3. | | | | |

TABLE 23.204-10: C-C LOT COVERAGE STANDARDS FOR RESIDENTIAL-ONLY USES

| | STANDARD BASED ON BUILDING HEIGHT [1] | | | SUPPLEMENTAL STANDARDS |
|---|---------------------------------------|-----------|-----------|--------------------------|
| | 1 STORY | 2 STORIES | 3 STORIES | |
| Lot Coverage, Maximum | | | | 23.304.120– Lot Coverage |
| Interior and Through Lots | 45% | 45% | 40% | |
| Corner Lots | 50% | 50% | 45% | |
| [1] Development standards included in this table may be modified with a UP(PH). See 23.204.050.D.3. | | | | |

3. Modification to Standards – Mixed-Use Open Space and Residential-Only Projects.

- a. The ZAB may modify the following standards with a Use Permit:
 - i. Minimum usable open space for mixed use projects shown in Table 23.204-8.
 - ii. Any standard for residential-only projects in Table 23.204-9 and Table 23.204-10.
- b. To approve the modification, the ZAB must find that the modification achieves one or more of the following:
 - i. Encourages use of the ground floor for commercial purposes where appropriate.
 - ii. Encourages utilization of public transit and existing off-street parking facilities in the area of the proposed building.
 - iii. Facilitates the construction of residential or tourist hotel uses where appropriate.

- iv. Permits consistency with the building setbacks existing in the immediate area where a residential building setback would not serve a useful purpose.

E. **Permit Findings.** To approve any AUP or Use Permit for a project in the C-C district, the review authority must make the findings in Section 23.406.040– Use Permits and find that the proposed use or structure:

1. Is compatible with the purpose of the district;
2. Is compatible with the surrounding uses and buildings;
3. Does not interfere with the continuity of retail and service facilities at the ground level; and
4. Does not exceed the amount and intensity of use that can be served by the available traffic capacity and potential parking supply.

23.204.060 – C-U University Commercial District

A. **District Purpose.** The purpose of the C-U University Commercial district is to:

1. Implement the General Plan's designations for Avenue Commercial areas;
2. Provide locations for a wide variety of activities along thoroughfares;
3. Encourage development in underutilized neighborhood and community shopping areas; and
4. Promote development compatible with adjacent commercial and residential areas.
5. Implement the University Avenue Strategic Plan by:
 - a. Increasing public safety for residents, merchants, and customers;
 - b. Revitalize the University Avenue corridor through appropriate economic development and housing;
 - c. Protecting and improving neighborhood quality of life;
 - d. Encourage more pedestrian-oriented development and an appropriate mix of uses to improve neighborhood identity;
 - e. Enhancing University Avenue as a gateway to the city, a series of neighborhoods, and the downtown;
 - f. Coordinating and enhance public transit systems, pedestrian access, and bicycle circulation; and
 - g. Encouraging a concentration of commercial activity at the designated nodes.

B. Allowed Land Uses.

1. **General.** See Table 23.204-1: Allowed Uses in the Commercial Districts.
2. **Alcoholic Beverage Retail Sales.** Alcoholic beverage retail sales are allowed in the C-U district only in conjunction with a restaurant or general food product store.
3. **Residential Uses.**
 - a. **Ground Floor Residential Uses.** Ground floor residential uses, including leasing and management offices and other similar resident-serving uses, require a Use Permit.
 - b. **University Avenue Node Area.** In the University Avenue Node Area shown in Figure 23.204-1: C-U District Sub-Areas, new residential uses must be integrated with non-residential uses in a mixed-use development.
 - c. **Outside of Node Area.** Single use residential projects are permitted outside of the University Avenue Node Area with a Use Permit.

FIGURE 23.204-1: C-U DISTRICT SUB-AREAS

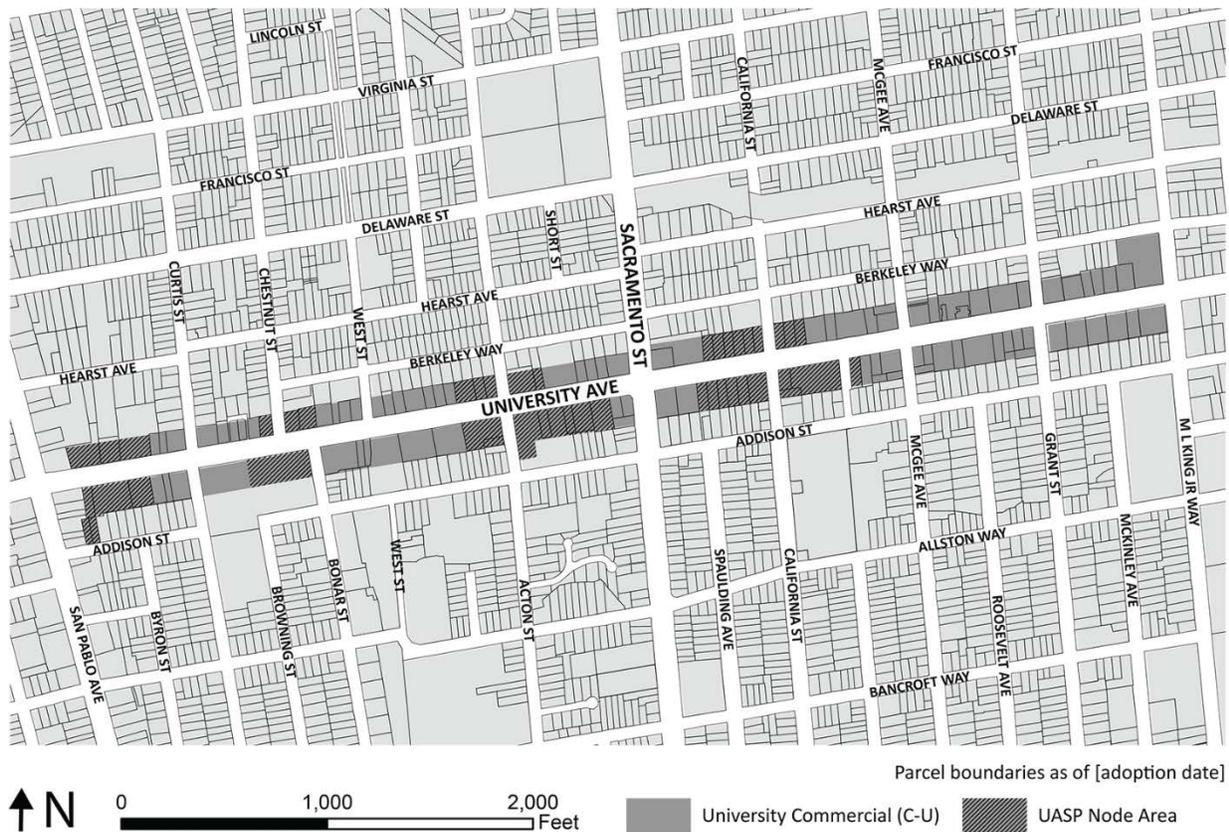

C. **Additional Permit Requirements.** See Section 23.204.030– Additional Permit Requirements.

D. **Development Standards.**

1. **Basic Standards.** See Table 23.204-11: C-U Development Standards and Table 23.204-12: C-U Setback Standards. For residential-only projects, see also Table 23.204-13: C-U Setback and Building Separation Standards for Residential Only Uses and Table 23.204-14: C-U Lot Coverage Standards for Residential-Only Uses. See Figure 23.204-1 for C-U district sub-area boundaries.

TABLE 23.204-11: C-U DEVELOPMENT STANDARDS

| | PROJECT LAND USE | | SUPPLEMENTAL STANDARDS |
|---|------------------------------|------------------|------------------------------|
| | NON-RESIDENTIAL OR MIXED USE | RESIDENTIAL ONLY | |
| Lot Area, Minimum | | | 23.304.020– Lot Requirements |
| New Lots | No minimum | 5,000 sq. ft. | |
| Per Group Living Accommodation Resident | 350 sq. ft. [1] | | |
| Floor Area Ratio, Maximum | | | |
| Avenue Mixed Use Area – North Side of University Avenue | 2.2 | No maximum | |
| Avenue Mixed Use Area – South Side of University Avenue | 2.5 | | |
| Node Area – North Side of University Avenue | 2.5 | | |
| Node Area – South Side of University Avenue | 3.0 | | |
| Main Building Height, Minimum | 30 ft. and 2 stories | | |
| Main Building Height, Maximum | | | 23.304.050– Building Height |
| Avenue Mixed Use Area, All Uses | 36 ft. and 3 stories [2] | N/A | |
| Node Area, Non-Residential | 40 ft. and 3 stories | | |

| | PROJECT LAND USE | | SUPPLEMENTAL STANDARDS |
|--|------------------------------|--|--|
| | NON-RESIDENTIAL OR MIXED USE | RESIDENTIAL ONLY | |
| Node Area, Mixed Use | 48 ft. and 4 stories [2] | | |
| Residential Only | N/A | 36 ft. and 3 stories | |
| Lot Line Setbacks, Minimum | See Table 23.204-12 | See Table 23.204-13 | 23.304.030– Setbacks |
| Building Separation, Minimum | No minimum | | 23.304.040– Building Separation in Residential Districts |
| Lot Coverage, Maximum | 100% | See Table 23.204-14Table 23.204-14: C-U Lot Coverage Standards for Residential-Only Uses | 23.304.120– Lot Coverage |
| Usable Open Space, Minimum | | | 23.304.090– Usable Open Space |
| Per Dwelling Unit | 200 sq. ft. [3] | | |
| Per Group Living Accommodation Resident | 90 sq. ft. [3] | | |
| <p>Notes:</p> <p>[1] One additional resident is allowed for remaining lot area between 200 and 350 square feet.</p> <p>[2] In mixed-use buildings, the third and higher floors must be used for residential purposes.</p> <p>[3] Minimum usable open space for mixed use and exclusive residential uses may be modified with a UP(PH). See 23.204.060.D.3.</p> | | | |

TABLE 23.204-12: C-U SETBACK STANDARDS

| LOT LINE & PROJECT CONDITIONS | REQUIRED SETBACK |
|-------------------------------|------------------|
| Front | |

| | |
|--|--|
| Ground-floor non-residential uses fronting University Avenue | Average 2 ft. 2 ft. at all sidewalk pedestrian entries |
| Ground-floor residential uses fronting University Avenue | Average 2 ft. Maximum 10 ft.[1] |
| Fronting a street other than University Avenue and confronting a non-residential district | No min. |
| Rear | |
| Lots on south side of University Avenue abutting lot in residential district | Average 20 ft. [2] [3] |
| Lots on south side of University Avenue | See 23.204.060.D.5– C-U University Commercial District (Solar Access) |
| All other lots | 10 ft. or 10% of lot depth, whichever is greater |
| Interior Side | No minimum |
| Street Side | 2 ft. average |
| All setbacks for lots on South Side of University Avenue fronting a street other than University Avenue | As required by 23.304.030.C.2– Setbacks (Lots Adjacent to Residential Districts) [4] |
| <p>Notes:</p> <p>[1] A maximum setback of 10 feet is only permitted for landscaping that enhances the streetscape and provides privacy for residential units on the first floor.</p> <p>[2] Rear setback area must be greater than or equal to the width of the lot in feet multiplied by 20 feet.</p> <p>[3] See 23.304.030.C.2.b for allowed reductions.</p> <p>[4] If a lot fronting a side street is consolidated into a single project with the adjacent University Avenue-fronting lot, the project must conform to the setback standards in this table.</p> | |

TABLE 23.204-13: C-U SETBACK AND BUILDING SEPARATION STANDARDS FOR RESIDENTIAL ONLY USES [1]

| | STANDARDS BY BUILDING STORY | | | SUPPLEMENTAL STANDARDS |
|----------------------------|----------------------------------|-----------------|-----------------|------------------------|
| | 1 ST | 2 ND | 3 RD | |
| Lot Line Setbacks, Minimum | | | | 23.304.030– Setbacks |
| Front | Average 2 ft. and 10 ft max. [2] | | | |
| Rear | 15 ft. | 15 ft. | 15 ft. | |

| | | | | |
|--|-------|--------|--------|--|
| Interior | 4 ft. | 4 ft. | 6 ft. | |
| Street Side | 6 ft. | 8 ft. | 10 ft. | |
| Building Separation, Minimum | 8 ft. | 12 ft. | 16 ft. | |
| Notes: | | | | |
| [1] Development standards included in this table may be modified with a UP(PH). See 23.204.060.D.3 | | | | |
| [2] Setback area must be used to accommodate landscaping that enhances the streetscape and provides a sense of privacy for residential units on the first floor. | | | | |

TABLE 23.204-14: C-U LOT COVERAGE STANDARDS FOR RESIDENTIAL-ONLY USES

| | STANDARD BASED ON BUILDING HEIGHT | | | SUPPLEMENTAL STANDARDS |
|---|-----------------------------------|-----------|-----------|------------------------|
| | 1 STORY | 2 STORIES | 3 STORIES | |
| Lot Coverage, Maximum [1] | | | | 23.304.120 |
| Interior and Through Lots | 45% | 45% | 40% | |
| Corner Lots | 50% | 50% | 45% | |
| [1] Development standards included in this table may be modified with a UP(PH). See 23.204.060.D.3. | | | | |

2. Lots Abutting or Confronting a Residential District.

- a. See 23.304.030.C.2– Setbacks (Lots Adjacent to Residential Districts) for additional setback and building feature requirements for lots:
 - i.* With a front lot line on University Avenue; and
 - ii.* That abut or confront a residential district.
- b. If the front lot line is not on University Avenue, 23.304.030.C.2– Setbacks (Lots Adjacent to Residential Districts) does not apply.

3. Modification to Standards – Mixed-Use Open Space and Residential-Only Projects.

- a. The ZAB may modify the following standards with a Use Permit:
 - i.* Minimum usable open space for mixed use projects and exclusive residential uses in Table 23.204-11.

| | | |
|--|----------------------------|----------------------------|
| Minimum floor to ceiling height | 12 ft. | 12 ft. |
| Minimum floor area [1] | 15% 10% with Use Permit | 30% 20% with Use Permit |
| Minimum street frontage [2] | 50% | 75% |
| Minimum area for retail sales, personal and household services, or food service [3] | No minimum | 75% 50% with Use Permit |
| Maximum area for office use [3] | No maximum | 25% |
| <p>Notes:</p> <p>[1] Calculated as percent of project land area.</p> <p>[2] Calculated as percent of project's University Avenue frontage.</p> <p>[3] Calculated as percentage of minimum required ground floor commercial floor area.</p> | | |

- b. Ground level commercial space shall be designed to allow for the space to be easily divided or assembled.

7. Ground Floor Commercial Uses – Minimum Floor Area Reductions.

- a. The ZAB may allow a reduction in the minimum required floor area to no less than indicated in Table 23.204-15 with a Use Permit for projects on lots that are:
 - i. Less than 7,500 square feet; and
 - ii. Without side street access (internal lots).
- b. To approve the reduction, the ZAB must find that:
 - i. Parking cannot be efficiently provided at grade and project parking conflicts with the requirement for ground floor commercial space;
 - ii. The reduced commercial area will result in a project with an enhanced commercial configuration; and
 - iii. The reduced commercial area promotes pedestrian-oriented activity along University Avenue through the mix of commercial uses, and/or the commercial uses will remain open beyond standard business hours, such as into the evening and on weekends, and the uses will be visible from University Avenue frontage.

8. Ground Floor Commercial Uses – Minimum Frontage Reduction. The ZAB may allow a reduction in the minimum required frontage requirement along

University Avenue as shown in Table 23.204-15 with a Use Permit upon finding that the minimum frontage requirement conflicts with:

- a. Minimum project site egress requirements;
- b. Minimum required driveway access to parking areas; or
- c. Project utility needs.

9. **Parking Areas for Residential-Only Projects.** All residential-only projects shall limit ground level parking uses directly fronting on University Avenue to no more than 25 percent of the project’s University Avenue frontage. All parking garage walls adjacent to University Avenue or side streets shall be articulated through design elements or material detailing to avoid blank walls extending more than 12 feet along the University Avenue or side street frontage.

10. **Open Space.** Projects shall provide open space features as shown in Table 23.204-16: C-U Open Space Features to enhance project entries and the University Avenue frontage.

TABLE 23.204-16: C-U OPEN SPACE FEATURES

| OPEN SPACE FEATURE | MINIMUM REQUIREMENT |
|---|---------------------|
| Mixed Use and Residential-Only Projects | |
| Minimum open space that is either: <ul style="list-style-type: none"> a. at street level; or b. on a parking podium directly connected to the project entries at the street level [1] | 10% |
| Minimum open space open to sky [1] | 75% |
| Projects with 100 feet or more of University Avenue Frontage | |
| Minimum area of pedestrian-oriented open spaces and improvements open to the sidewalk [2] | 1% |
| Minimum width and length of street level plaza or entry courtyard | 6 ft. |
| Notes: [1] Calculated as percentage of minimum resident-serving open spaced required by Section 23.304.090– Usable Open Space. Open space must be accessible to building occupants. [2] Calculated percentage of project land area. | |

11. **Sidewalk/Curb and Gutter.** Projects shall provide sidewalk, curb and gutter, and street corner bulb-out improvements as necessary to comply with the current City standards.

12. **Sidewalk Amenities.** Projects shall provide sidewalk amenities as necessary to comply with the current City standards. Required improvement may include:

- a. Pedestrian-scaled lighting to illuminate the sidewalk areas;
- b. New street trees and grates; and
- c. Benches and bicycle racks.

E. **Permit Findings.** To approve an AUP or Use Permit for a project in the C-U district, the review authority must make the findings in Section 23.406.040 (Use Permits) and find that the proposed use or structure:

1. Is compatible with the purpose of the district;
2. Is compatible with the surrounding uses and buildings;
3. Does not interfere with the continuity of retail and service facilities at the ground level; and
4. Does not exceed the amount and intensity of use that can be served by the available traffic capacity and potential parking supply.

23.204.070 – C-N Neighborhood Commercial District

A. **District Purpose.** The purpose of the Neighborhood Corridor (C-N) district is to:

1. Implement the General Plan's designations for Neighborhood Commercial areas;
2. Provide locations for uses supplying convenience goods and services for residents of the immediate area;
3. Provide locations for other activities compatible with allowed commercial uses;
4. Minimize traffic and parking problems for the adjacent residential areas; and
5. Promote compatibility between commercial areas and nearby residential areas.

B. **Allowed Land Uses.** See Table 23.204-1: Allowed Uses in the Commercial Districts.

C. **Additional Permit Requirements.** See Section 23.204.030 (Additional Permit Requirements).

D. **Development Standards.**

1. **Basic Standards.** See Table 23.204-17: C-N Development Standards. For

residential-only projects, see also Table 23.204-18: C-N Setback and Building Separation Standards for Residential-Only Uses and

2. Table 23.204-19: C-N Lot Coverage Standards for Residential-Only Uses.

TABLE 23.204-17: C-N DEVELOPMENT STANDARDS

| | Project Land Use | | | Supplemental Standards |
|---|----------------------|--------------------------|----------------------|-------------------------------|
| | Non-Residential | Mixed Use | Residential Only | |
| Lot Area, Minimum | | | | 23.304.020– Lot Requirements |
| New Lots | No minimum | | 5,000 sq. ft. | |
| Per Group Living Accommodation Resident | 350 sq. ft. [1] | | | |
| Usable Open Space, Minimum | | | | 23.304.090– Usable Open Space |
| Per Dwelling Unit | 200 sq. ft. | 200 sq. ft.[2] | 200 sq. ft. | |
| Per Group Living Accommodation Resident | 90 sq. ft. | 90 sq. ft. [2] | 90 sq. ft. | |
| Floor Area Ratio, Maximum | 3.0 | | No maximum | |
| Main Building Height, Maximum | 35 ft. and 2 stories | 35 ft. and 3 stories [3] | 35 ft. and 3 stories | 23.304.050– Building Height |
| Lot Line Setbacks, Minimum | | | | |
| Abutting/Confronting a Non-residential District | No minimum | | See Table 23.204-18 | |
| Abutting/Confronting a Residential District | See 23.304.030.C.2 | | | |
| Building Separation, Minimum | No minimum | | | |
| Lot Coverage, Maximum | 100% | | See Table 23.204-19 | |

| | Project Land Use | | | Supplemental Standards |
|--|------------------|-----------|------------------|------------------------|
| | Non-Residential | Mixed Use | Residential Only | |
| Notes: | | | | |
| [1] One additional resident is allowed for remaining lot area between 200 and 350 square feet. | | | | |
| [2] Minimum open space for mixed use projects can be modified with a UP(PH). See 23.204.070.D.3. | | | | |
| [3] In mixed use buildings, the third and higher stories must be used for residential purposes. | | | | |

TABLE 23.204-18: C-N SETBACK AND BUILDING SEPARATION STANDARDS FOR RESIDENTIAL-ONLY USES

| | STANDARDS BY BUILDING STORY | | | SUPPLEMENTAL STANDARDS |
|---|-----------------------------|-----------------|-----------------|--|
| | 1 ST | 2 ND | 3 RD | |
| Lot Line Setbacks, Minimum [1] | | | | 23.304.030– Setbacks |
| Front | 15 ft. | 15 ft. | 15 ft. | |
| Rear | 15 ft. | 15 ft. | 15 ft. | |
| Interior | 4 ft. | 4 ft. | 6 ft. | |
| Street Side | 6 ft. | 8 ft. | 10 ft. | |
| Building Separation, Minimum [1] | 8 ft. | 12 ft. | 16 ft. | 23.304.040– Building Separation in Residential Districts |
| [1] Development standards included in this table can be modified with a UP(PH). See 23.204.070.D.3. | | | | |

TABLE 23.204-19: C-N LOT COVERAGE STANDARDS FOR RESIDENTIAL-ONLY USES

| | STANDARD BASED ON BUILDING HEIGHT | | | SUPPLEMENTAL STANDARDS |
|---------------------------|-----------------------------------|-----------|-----------|--------------------------|
| | 1 STORY | 2 STORIES | 3 STORIES | |
| Lot Coverage, Maximum [1] | | | | 23.304.120– Lot Coverage |
| Interior and Through Lots | 45% | 45% | 40% | |

| | | | | |
|---|-----|-----|-----|--|
| Corner Lots | 50% | 50% | 45% | |
| [1] Development standards included in this table can be modified with a UP(PH). See 23.204.070.D.3. | | | | |

3. **Lots Abutting or Confronting a Residential District.** See Section 23.304.130– Non-Residential Districts Abutting a Residential District for additional building feature requirements for lots that abut or confront a Residential District.

4. **Modification to Standards – Mixed-Use Open Space and Residential-Only Projects.**

a. The ZAB may modify the following standards with a Use Permit:

- i.* Minimum usable open space for mixed use projects shown in Table 23.204-17: C-N Development Standards.
- ii.* Any standard for residential-only projects in Table 23.204-18: C-N Setback and Building Separation Standards for Residential-Only Uses and
- iii.* Table 23.204-19: C-N Lot Coverage Standards for Residential-Only Uses.

b. To approve the modification, the ZAB must find that the modification achieves one or more of the following:

- i.* Encourages use of the ground floor for commercial purposes where appropriate.
- ii.* Encourages utilization of public transit and existing off-street parking facilities in the area of the proposed building.
- iii.* Facilitates the construction of residential or tourist hotel uses where appropriate.
- iv.* Permits consistency with the building setbacks existing in the immediate area where a residential building setback would not serve a useful purpose.

E. **Permit Findings.** To approve any AUP or Use Permit for a project in the C-N district, the review authority must make the findings in Section 23.406.040– Use Permits and find that the proposed use or structure:

- 1. Is compatible with the purpose of the district;
- 2. Is compatible with the surrounding uses and buildings;
- 3. Does not interfere with the continuity of retail and service facilities at the ground level; and

4. Does not exceed the amount and intensity of use that can be served by the available traffic capacity and potential parking supply.

23.204.080 – C-E Elmwood Commercial District

A. District Purpose. The purpose of the Elmwood Commercial (C-E) district is to:

1. Implement the General Plan’s designation for a community commercial district in this area;
2. Maintain a scale and balance of retail goods and services in the district to compatibly serve the everyday needs of surrounding neighborhoods by:
 - a. Providing locations for retail goods and service establishments to serve surrounding neighborhoods;
 - b. Preventing development which exceeds the amount and intensity of use that is compatible with adjacent residential neighborhoods;
 - c. Limiting the space occupied by businesses that generate high traffic and/or parking demands;
 - d. Controlling the proliferation of establishments which, if not limited, might expand to displace establishments needed to serve surrounding neighborhoods; and
 - e. Permitting other uses which serve this objective; and
3. Ensure that new buildings, alterations, and additions to existing buildings harmonize with their surroundings.

B. Land Use Regulations.

1. **Allowed Land Uses.** See Table 23.204-1: Allowed Uses in the Commercial Districts.
2. **Numerical and Size Limitations.**
 - a. Table 23.204-20 shows land uses subject to numerical and size limitations in the C-E district.

TABLE 23.204-20: C-E LAND USE NUMBER AND SIZE LIMITATIONS

| USE | NUMBER LIMIT | MAXIMUM SIZE | PERMIT REQUIRED |
|--|--------------|---------------|-----------------|
| Art/Craft Shops, Gift/Novelty Shops, Jewelry/Watch Shops | No limit | 1,500 sq. ft. | ZC |
| Bookstores, Periodical Stands | No limit | 2,000 sq. ft. | ZC |

| | | | |
|--|----------|---------------|--------------------|
| Food Service Establishments [1] | 25 total | No max. | No permit required |
| Photocopy Stores, Printing, Fax, Magnetic Disk Reproduction Services | No limit | 1,000 sq. ft. | ZC |
| Notes: [1] Excludes food service uses accessory to a food product store. Secondary food service uses associated with all other principal uses are subject to limitations in Table 23.204-20. [2] Change of use of over 3,000 square feet requires Use Permit | | | |

- b. The ZAB may allow a use to exceed the limitations in Table 23.204-20 with a Use Permit upon finding that:
 - i. The use will result in the positive enhancement of the purposes of the district; and
 - ii. The use is likely to experience substantial patronage by surrounding residents as indicated by neighborhood resident support, merchant support, marketing surveys, or other information.

3. **Incidental Wholesale Activities.** In the C-E district, wholesale activities incidental to a primary use require permits as follows:

- a. Six or fewer employees: Zoning Certificate.
- b. Seven or more employees: AUP.
- c. New construction: Use Permit.

C. **Additional Permit Requirements.** See Section 23.204.030 (Additional Permit Requirements).

D. **Development Standards.**

- 1. **Basic Standards.** See Table 23.204-21: C-E Development Standards. For residential-only projects, also see Table 23.204-22: C-E Setback and Building Separation Standards for Residential-Only Uses and Table 23.204-23: C-E Lot Coverage Standards for Residential-Only Uses.

TABLE 23.204-21: C-E DEVELOPMENT STANDARDS

| | Project Land Use | | Supplemental Standards |
|-------------------|-------------------------------|------------------|------------------------|
| | Non-Residential and Mixed Use | Residential Only | |
| Lot Area, Minimum | No minimum | 5,000 sq. ft. | 23.304.020– |

| | | | |
|---|--------------------------|----------------------|------------------------------|
| New Lots | No minimum | 5,000 sq. ft. | Lot Requirements |
| Per Group Living Accommodation Resident | 350 sq. ft. [1] | | |
| Usable Open Space | | | 23.304.090–Usable Open Space |
| Per Dwelling Unit | 200 sq. ft. [2] | | |
| Per Group Living Accommodation Resident | 90 sq. ft.[2] | | |
| Floor Area Ratio, Maximum | | | |
| Corner Lot | 1.0 | No maximum | |
| All Other Lot | 0.8 | | |
| Main Building Height, Minimum | No minimum | No minimum | |
| Main Building Height, Maximum | 28 ft. and 2 stories [3] | 35 ft. and 3 stories | |
| Lot Line Setbacks, Minimum | | | 23.304.030–Setbacks |
| Abutting/Confronting a Non-residential District | No minimum | See Table 23.204-22 | |
| Abutting/Confronting a Residential District | See Table 23.304-3 | | |
| Building Separation, Minimum | No minimum | See Table 23.204-22 | |
| Lot Coverage, Maximum | 100% | See Table 23.204-23 | 23.304.120–Lot Coverage |
| Notes: | | | |
| [1] One additional resident is allowed for remaining lot area between 200 and 350 square feet. | | | |
| [2] Open space requirements for mixed use projects may be modified by the ZAB. See 23.204.060.D.3 | | | |
| [3] A basement level devoted exclusively to parking is not counted as a story. | | | |

TABLE 23.204-22: C-E SETBACK AND BUILDING SEPARATION STANDARDS FOR RESIDENTIAL-ONLY USES

| | STANDARDS BY BUILDING STORY | SUPPLEMENTAL STANDARDS |
|--|-----------------------------|------------------------|
|--|-----------------------------|------------------------|

| | 1 ST | 2 ND | 3 RD | |
|------------------------------|-----------------|-----------------|-----------------|---|
| Lot Line Setbacks, Minimum | | | | 23.304.030– Setbacks |
| Front | 15 ft. | 15 ft. | 15 ft. | |
| Rear | 15 ft. | 15 ft. | 15 ft. | |
| Interior | 4 ft. | 4 ft. | 6 ft. | |
| Street Side | 6 ft. | 8 ft. | 10 ft. | |
| Building Separation, Minimum | 8 ft. | 12 ft. | 16 ft. | 23.304.040– Building Separation in Residential Districts |

TABLE 23.204-23: C-E LOT COVERAGE STANDARDS FOR RESIDENTIAL-ONLY USES

| | STANDARD BASED ON BUILDING HEIGHT | | | SUPPLEMENTAL STANDARDS |
|---------------------------|-----------------------------------|-----------|-----------|-----------------------------|
| | 1 STORY | 2 STORIES | 3 STORIES | |
| Lot Coverage, Maximum | | | | 23.304.120– Lot Coverage |
| Interior and Through Lots | 45% | 45% | 40% | |
| Corner Lots | 50% | 50% | 45% | |

2. **Lots Abutting or Confronting a Residential District.** See 23.304.130 (Non-residential Districts Abutting a Residential District) for additional building feature requirements for lots that abut or confront a Residential District.
3. **Modifications to Standards – Mixed Use Open Space.** The ZAB may modify the usable open space requirement shown in Table 23.204-21 for mixed-use projects by finding that the modification achieves one or more of the following:
 - a. The modification encourages and maintains the present street frontage and pedestrian orientation of the district.
 - b. The modification is compatible in design and character with the commercial district and the adjacent residential neighborhoods.
 - c. The modification is compatible with the purposes set forth in Section 23.204.080.A (District Purpose) and the existing character of the district.
4. **Ground Floor Residential Uses.** A ground floor residential use must be setback at least 20 feet from a property line along College or Ashby Avenue.

5. Projections into Right-of-Way.

- a. Bay windows and balconies 11 feet or more above the sidewalk grade may project 3 feet into a street right-of-way.
- b. A maximum 60 percent of the length of a building frontage may project beyond the property line.
- c. All projections require a revocable encroachment permit from the City Council.

E. Permit Findings. To approve an AUP or Use Permit for a project in the C-E district, the review authority must make the findings in Section 23.406.040 (Use Permits) and find the following:

- 1. The proposed use or structure will:
 - a. Encourage and maintain the present street frontage and pedestrian orientation of the district;
 - b. Be compatible in design and character with the commercial district and the adjacent residential neighborhoods; and
 - c. Be compatible with the purposes set forth in Section 23.204.080.A (District Purpose).and the existing character of the district.
- 2. The proposed use or structure will not:
 - a. Interfere with the continuity of retail or compatible service facilities at the ground level;
 - b. Interrupt a continuous wall of building facades;
 - c. Generate traffic and parking demand beyond the capacity of the commercial district or significantly increase impacts on adjacent residential neighborhoods;
 - d. Result in domination of this district by one type of use; and
 - e. Generate objectionable odors nor excessive levels of noise.

23.204.090 – C-NS North Shattuck Commercial District

A. District Purpose. The purpose of the North Shattuck Commercial (C-NS) district is to:

- 1. Implement the General Plan's designations for Community Commercial and Commercial/Residential in this area;

2. Encourage the maintenance and establishment of retail and service activities that provide goods and services to serve the residents of the adjacent and outlying neighborhoods; but do not generate high traffic volume;
3. Provide locations for other activities compatible with these commercial activities;
4. Promote compatibility between such commercial areas and adjacent residential neighborhoods;
5. Limit the space occupied by businesses that generate high traffic volumes;
6. Support the retention of types of businesses serving adjacent neighborhoods;
7. Limit space occupied by commercial uses, especially offices, that are more appropriately located in the downtown business district;
8. Prevent development of commercial spaces exceeding the amount and intensity of use that can be served by available traffic capacity and potential parking supply;
9. Encourage an adequate commercial and residential mix along Shattuck Avenue; and
10. Ensure that new buildings and additions to existing buildings harmonize with their surroundings.

B. Allowed Land Uses. See Table 23.204-1: Allowed Uses in the Commercial Districts.

C. Additional Permit Requirements. See Section 23.204.030 (Additional Permit Requirements).

D. Development Standards.

1. **Basic Standards.** See Table 23.204-24: C-NS Development Standards. See also Table 23.204-25: C-NS Setback Standards for Residential-Only Uses and Building Separation Standards for Mixed Use and Residential-Only Uses and Table 23.204-26: C-NS Lot Coverage Standards for Residential-Only Uses.

TABLE 23.204-24: C-NS DEVELOPMENT STANDARDS

| | Project Land Use | | Supplemental Standards |
|---|-------------------------------|------------------|------------------------|
| | Non-Residential and Mixed Use | Residential Only | |
| Lot Area, Minimum | | | 23.304.020 |
| New Lots | 4,000 sq. ft. | 5,000 sq. ft. | |
| Per Group Living Accommodation Resident | 350 sq. ft. [1] | | |

| | Project Land Use | | Supplemental Standards |
|---|-------------------------------|----------------------|-------------------------------|
| | Non-Residential and Mixed Use | Residential Only | |
| Usable Open Space, Minimum | | | 23.304.090– Usable Open Space |
| Per Dwelling Unit | 200 sq. ft. | 200 sq. ft. | |
| Per Group Living Accommodation Resident | No minimum | 90 sq. ft. | |
| Floor Area Ratio, Maximum | 1.0 | No maximum | |
| Main Building Height [2] | | | |
| Minimum | 2 stories | No minimum | |
| Maximum | 35 ft. and 3 stories | 28 ft. and 2 stories | |
| Lot Line Setbacks, Minimum | | | 23.304.030 |
| Abutting/Confronting a Non-residential District | No minimum | See Table 23.204-25 | |
| Abutting/Confronting a Residential District | See 23.304.030.C.2 | | |
| Building Separation, Minimum | No minimum [4] | See Table 23.204-25 | 23.304.040 |
| Lot Coverage, Maximum | 100% | See Table 23.204-26 | 23.304.120 |
| <p>Notes:</p> <p>[1] One additional resident is allowed for remaining lot area between 200 and 350 square feet.</p> <p>[2] Basement levels devoted exclusively to parking are not counted as a story.</p> <p>[3] For mixed-use projects, minimum building separation shall be as required for residential-only projects. See Table 23.204-25</p> <p>[4] No dimension may be less than 6 feet.</p> | | | |

TABLE 23.204-25: C-NS SETBACK STANDARDS FOR RESIDENTIAL-ONLY USES AND BUILDING SEPARATION STANDARDS FOR MIXED USE AND RESIDENTIAL-ONLY USES

| | STANDARDS BY BUILDING STORY | | | SUPPLEMENTAL STANDARDS |
|----------------------------|-----------------------------|-----------------|-----------------|------------------------|
| | 1 ST | 2 ND | 3 RD | |
| Lot Line Setbacks, Minimum | | | | 23.304.030– |

| | | | | |
|------------------------------|--------|--------|--------|--|
| Front | 15 ft. | 15 ft. | 15 ft. | Setbacks |
| Rear | 15 ft. | 15 ft. | 15 ft. | |
| Interior | 4 ft. | 4 ft. | 6 ft. | |
| Street Side | 6 ft. | 8 ft. | 10 ft. | |
| Building Separation, Minimum | 8 ft. | 12 ft. | 16 ft. | 23.304.040– Building Separation in Residential Districts |

TABLE 23.204-26: C-NS LOT COVERAGE STANDARDS FOR RESIDENTIAL-ONLY USES

| | STANDARD BASED ON BUILDING HEIGHT | | | SUPPLEMENTAL STANDARDS |
|--------------------------|-----------------------------------|-----------|-----------|--------------------------|
| | 1 STORY | 2 STORIES | 3 STORIES | |
| Lot Coverage, Maximum | | | | 23.304.120– Lot Coverage |
| Interior and Through Lot | 45% | 45% | 40% | |
| Corner Lot | 50% | 50% | 45% | |

1. **Lots Abutting or Confronting a Residential District.** See Section 23.304.130– Non-Residential Districts Abutting a Residential District for additional building feature requirements for lots that abut or confront a Residential District.
2. **Ground Floor Dwelling Units in Mixed-Use Buildings.** Ground floor dwelling units in a mixed-use building shall be located at least 20 feet from a property line next to a public right-of-way.
3. **Residential Window Setback.** Mixed-use buildings shall be setback at least ten feet from an interior property line opposite a required window in any habitable room of a residential use.

E. Permit Findings. To approve an AUP or Use Permit for a project in the C-NS district, the review authority must make the findings in Section 23.406.040– Use Permits and find that the proposed use or structure:

1. Is compatible in design and character with the commercial district and the adjacent residential neighborhoods;
2. Is compatible with the purposes and the existing character of the district.
3. Does not interfere with the continuity of retail or compatible service facilities at the ground level;

4. Does not exceed the amount and intensity of use that can be served by available traffic capacity and potential parking supply.

23.204.100 – C-SA South Area Commercial District

A. **District Purpose.** The purpose of the South Area Commercial (C-SA) district is to:

1. Implement the General Plan's designations for Community Commercial, and the Commercial/Residential areas, as well as the policies of the South Berkeley Area Plan;
2. Provide locations for both community-serving and regional-serving businesses, particularly those which reflect the culture of the surrounding area;
3. Provide an area of neighborhood and lower intensity community commercial uses, serving as a transition between the Downtown area and the neighborhood-serving area south of Ashby Avenue;
4. Encourage the location of a wide variety of community-oriented retail goods and services in South Berkeley;
5. Encourage residential development for persons who desire both the convenience of location and more open space than is available in the Downtown;
6. Provide limited locations for other activities such as offices which may be compatible with both retail and residential uses;
7. Encourage development and amenities that support pedestrian-oriented uses;
8. Encourage appropriate mixed-use development (retail/office/residential) on appropriate sites in the district; and
9. Increase the opportunities for the establishment of businesses which are owned and operated by local residents.

B. **Allowed Land Uses.**

1. **General.** See Table 23.204-1: Allowed Uses in the Commercial Districts
2. **Alcoholic Beverage Retail Sales.** The sale and service of distilled alcoholic beverages (hard liquor) is not permitted along Adeline Street, south of Ashby Avenue, except that such service is allowed when incidental to meals at full-service restaurants in accordance with Section 23.310—Alcoholic Beverage Sales and Service.
3. **Bar/Cocktail Lounge/Tavern.** Service of distilled alcoholic beverages is allowed along Adeline Street south of Ashby Avenue only when incidental to seated food service.
4. **Mixed-Use Permits Required.**

- a. **Zoning Certificate.** A mixed-use project is allowed with a Zoning Certificate if the project:
 - i.* Complies with all applicable standards in Table 23.204-27, Table 23.204-28, and Table 23.204-29;
 - ii.* Includes only residential uses above the ground floor; and
 - iii.* Is less than 5,000 square feet in gross floor area, including any existing floor area incorporated into the project.
- b. **Use Permit.** If a mixed-use project does not meet the criteria for approval with a Zoning Certificate as provided above, the project requires a Use Permit and is subject to the findings in Section 23.204.100.E– C-SA South Area Commercial District (Permit Findings).

5. **Automobile/Motorcycle Sales.**

a. **Applicability.**

- i.* In the C-SA district, small vehicle service is not permitted. Small vehicle sales that are exclusively indoor operations are permitted with a Zoning Certificate. Otherwise, a Use Permit is required.
- ii.* All new or relocated automobile or motorcycle sales in the C-SA district shall comply with the requirements of this subsection.
- iii.* Expansions or modifications of existing automobile or motorcycle sales are:
 - 1. Encouraged to comply with standards in Paragraph c (Standards) below where feasible; and
 - 2. Shall not increase or exacerbate a non-conformity with these standards.

- b. **Where Allowed.** New or relocated automobile or motorcycle sales uses with outdoor activities, including but not limited to storage and display of vehicle inventory, are limited to the Dealership Overlay Area as shown in Figure 23.204-2: C-SA Dealership Overlay Area.

FIGURE 23.204-2: C-SA DEALERSHIP OVERLAY AREA



c. **Standards.**

- i.* **Street Frontage.** Outdoor vehicle display is permitted only along Shattuck Avenue and Adeline Street and is limited to 30 percent of the lot frontage on those streets.
- ii.* **Area for Outdoor Uses.** A maximum of 40 percent of the lot area may be used for outdoor uses, including but not limited to vehicle display and storage. Adequate landscaping and/or fencing shall be used to filter the view of outdoor uses from the adjacent right-of-way and abutting properties, with the exception of outdoor vehicle display;
- iii.* **Service Entries.** Vehicle and repair service entries may not exceed 20 percent of the primary lot frontage, no entrance may exceed a width of 20 feet. The primary street frontage is the frontage towards which the primary building entrance is oriented.
- iv.* **Transparency.** At least 60 percent of any new building shall be within 10 feet of the right-of-way along the primary street frontage and 60 percent of the street-facing facade shall be comprised of clear glass.
- v.* **Repair Activities.** All vehicle repair activities shall be conducted indoors.
- vi.* **Noise.** All noise-generating equipment and activities, such as vehicle repair, shall be shielded by noise-attenuating materials. Outdoor amplification is not permitted.
- vii.* **Lighting.** Exterior light standards and fixtures shall not be taller than 20 feet, shall achieve uniform light coverage and minimize glare, shall use light cutoffs to control light spillover onto adjacent properties and urban sky glow, and shall use low energy light fixtures consistent with the City's goals for energy efficiency.
- viii.* **Vehicle Storage.** No vehicles shall be stored in the public right-of-way.

d. **Modification of Standards.** The Zoning Officer may allow modification to standards in Paragraph c (Standards) above with an AUP upon finding that the modification:

- i.* Is necessary to facilitate incorporation of an existing structure;
- ii.* Achieve greater consistency with the surrounding street pattern;
- iii.* Buffers impacts to an adjacent residential district; or
- iv.* Is needed to accommodate dealership operations.

C. **Additional Permit Requirements.** See Section 23.204.030– Additional Permit Requirements.

D. Development Standards.

1. **Basic Standards.** See Table 23.204-27: C-SA Development Standards and Table 23.204-28: C-SA Maximum Building Height. For residential-only projects, see also Table 23.204-29: C-SA Setback and Building Separation Standards for Mixed Use and Residential-Only Uses and Table 23.204-30: C-SA Lot Coverage Standards for Mixed Use and Residential-Only Uses.

TABLE 23.204-27: C-SA DEVELOPMENT STANDARDS

| | Project Land Use | | | Supplemental Standards |
|---|---------------------|---------------------|------------------|-------------------------------|
| | Non-Residential | Mixed Use | Residential Only | |
| Lot Area, Minimum | | | | 23.304.020 |
| New Lots | No minimum | No minimum | 5,000 sq. ft. | |
| Per Group Living Accommodation Resident | No minimum | 350 sq. ft. [1] | | |
| Usable Open Space, Minimum | | | | 23.304.090– Usable Open Space |
| Per Dwelling Unit | N/A | 40 sq. ft. [3] | 200 sq. ft. | |
| Per Group Living Accommodation Resident | N/A | No minimum | 90 sq. ft. | |
| Floor Area Ratio, Maximum | 4.0 | 4.0 | No maximum | |
| Main Building Height, Minimum | No minimum | | | |
| Main Building Height, Maximum | See Table 23.204-28 | | | |
| Lot Line Setbacks, Minimum | | | | 23.304.030– Setbacks |
| Abutting/Confronting a Non-residential District | No minimum | See Table 23.204-29 | | |
| Abutting/Confronting a Residential District | See 23.304.030. C.2 | | | |

| | Project Land Use | | | Supplemental Standards |
|---|------------------|---------------------|------------------|---|
| | Non-Residential | Mixed Use | Residential Only | |
| Building Separation, Minimum | No minimum | See Table 23.204-29 | | 23.304.040– Building Separation in Residential Districts |
| Lot Coverage, Maximum | 100% | See Table 23.204-30 | | 23.304.120– Lot Coverage |
| Notes: [1] One additional resident is allowed for remaining lot area between 200 and 350 square feet. [2] For mixed-use projects, minimum building separation shall be as required for residential-only projects [3] No dimension may be less than 6 feet. | | | | |

TABLE 23.204-28: C-SA MAXIMUM BUILDING HEIGHT

| BUILDING LAND USE | MAXIMUM HEIGHT | | |
|---|----------------------|----------------------|----------------------|
| | SUBAREA 1 | SUBAREA 2 | SUBAREA 3 |
| Non-Residential Uses | 36 and 3 stories | 24 and 2 stories | 24 and 2 stories |
| Mixed Use and Residential Only | 60 and 5 stories [1] | 50 and 4 stories [1] | 36 and 3 stories [1] |
| Notes: [1] In mixed-use buildings, the third story and above must be used for residential purposes entirely. | | | |

FIGURE 23.204-3: C-SA BUILDING HEIGHT SUB-AREAS

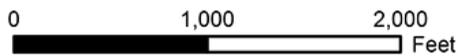
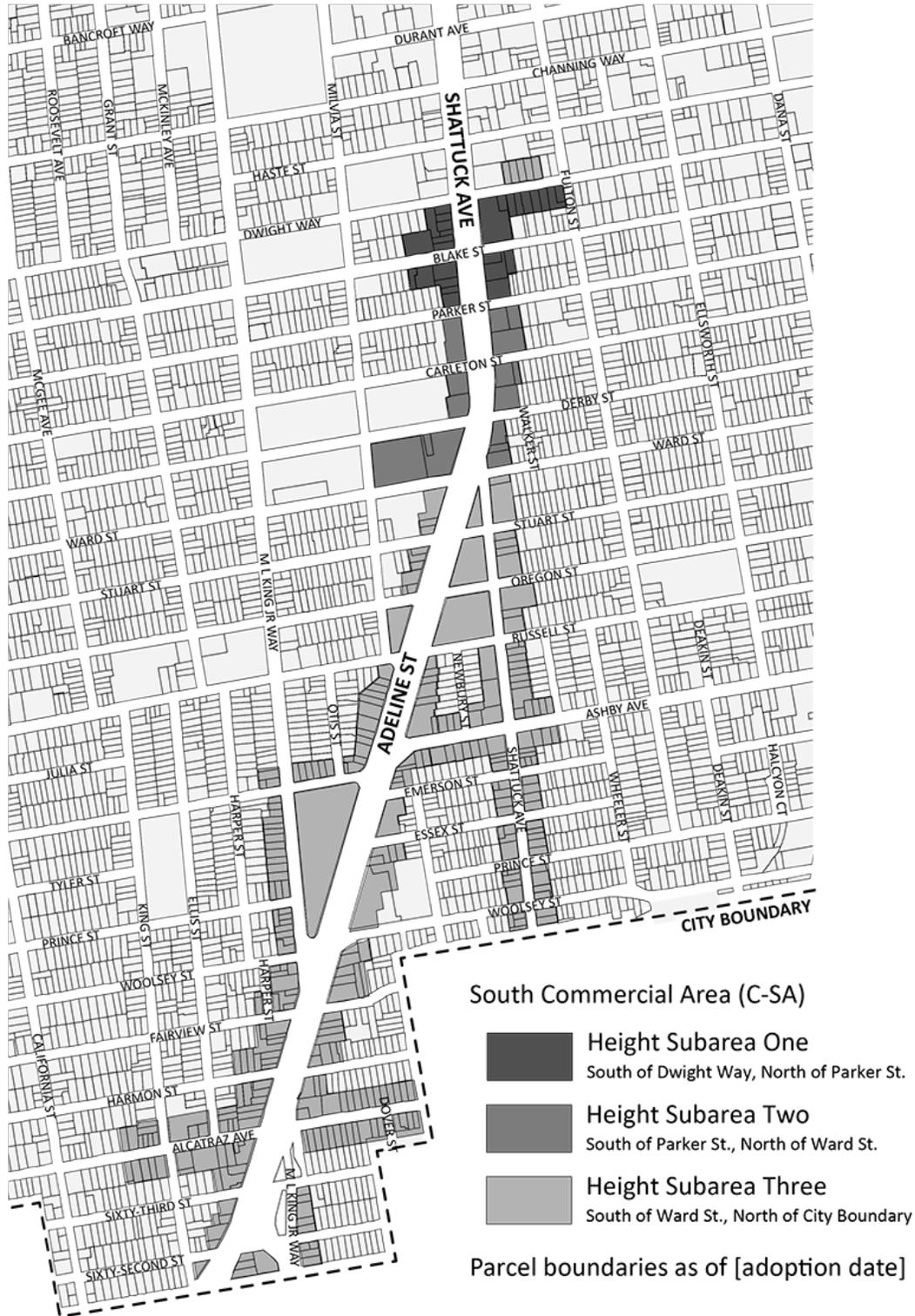

TABLE 23.204-29: C-SA SETBACK AND BUILDING SEPARATION STANDARDS FOR MIXED USE AND RESIDENTIAL-ONLY USES

| | STANDARDS BY BUILDING STORY | | | | | | Supplemental Standards |
|------------------------------|-----------------------------|-----------------|-----------------|-----------------|-----------------|-----------------|---|
| | 1 st | 2 nd | 3 rd | 4 th | 5 th | 6 th | |
| Lot Line Setbacks, Minimum | | | | | | | 23.304.030– Setbacks |
| Front | 15 ft. | 15 ft. | 15 ft. | 15 ft. | 15 ft. | 15 ft. | |
| Rear | 15 ft. | 15 ft. | 15 ft. | 15 ft. | 15 ft. | 15 ft. | |
| Interior | 4 ft. | 4 ft. | 6 ft. | 8 ft. | 10 ft. | 12 ft. | |
| Street Side | 6 ft. | 8 ft. | 10 ft. | 12 ft. | 14 ft. | 15 ft. | |
| Building Separation, Minimum | 8 ft. | 12 ft. | 16 ft. | 20 ft. | 24 ft. | 28 ft. | 23.304.040– Building Separation in Residential Districts |

TABLE 23.204-30: C-SA LOT COVERAGE STANDARDS FOR MIXED USE AND RESIDENTIAL-ONLY USES

| | STANDARD BASED ON BUILDING HEIGHT | | | | | | SUPPLEMENTAL STANDARDS |
|---------------------------|-----------------------------------|-----------|-----------|-----------|-----------|-----------|-----------------------------|
| | 1 STORY | 2 STORIES | 3 STORIES | 4 STORIES | 5 STORIES | 6 STORIES | |
| Lot Coverage, Maximum | | | | | | | 23.304.120– Lot Coverage |
| Interior and Through Lots | 45% | 45% | 35% | 35% | 35% | 35% | |
| Corner Lots | 50% | 50% | 45% | 40% | 40% | 40% | |

2. **Modification for Mixed Use and Residential Projects.** The ZAB may modify development standards in Table 23.204-27, Table 23.204-28, and Table 23.204-29, and Table 23.204-30 for a mixed-use or residential-only project with a Use Permit upon making one of the following findings:
 - a. The project encourages utilization of public transit and existing off-street parking facilities in the area of the proposed building;
 - b. The modification allows consistency with the building setbacks existing in the immediate area where a residential building setback would not serve a useful purpose;

- c. The modification facilitates the construction of affordable housing as defined by the U.S. Department of Housing and Urban Development (HUD) Guidelines; or
 - d. The modification provides consistency with the purposes of the district as listed in Section 23.204.100.A (District Purpose).
- E. **Findings.** To approve an AUP or Use Permit for a project in the C-SA district, the review authority must make the findings in Section 23.406.040 (Use Permits) and find that the proposed use or structure:
- 1. Is compatible with the purposes of the district;
 - 2. Is compatible in design and character with the district and the adjacent residential neighborhoods; and
 - 3. Will not result in the domination of one type of commercial/retail use in any one area of the district.

23.204.110 – C-T Telegraph Avenue Commercial District

- A. **District Purpose.** The purpose of the Telegraph Avenue Commercial (C-T) district is to:
- 1. Implement the General Plan's designation of Avenue Commercial for this area;
 - 2. Implement the Southside Plan's designation for the Telegraph Avenue Commercial Subarea;
 - 3. Regulate development in the Telegraph Avenue area to satisfy the needs of the population groups using the district, especially the University population and the surrounding resident population;
 - 4. Encourage the availability of a variety of goods and services which serve residents in the district and the University population but do not generate a high volume of vehicular traffic;
 - 5. Allow for uses which maintain the cultural quality of the district giving it its regional appeal without generating substantial vehicular traffic;
 - 6. Discourage uses which, because of size, the type of the products sold, vehicular traffic generated or other considerations, are more appropriately located elsewhere in the city;
 - 7. Encourage a mix of goods and services which will prevent the dominance of any one type of use and which will produce variations within the same category of uses;

8. Encourage the establishment and maintenance of uses which will satisfy the needs of all age groups and attract a range of users and interests;
9. Encourage the creation of additional housing in the district which is affordable, including housing for those who work or study nearby;
10. Encourage those uses and structural architecture that reinforce, and discourage those uses and architecture that interrupt, the pedestrian orientation of the district;
11. Encourage mixed commercial and residential uses;
12. Encourage the construction of new housing in mixed use development on vacant properties and surface parking lots;
13. Encourage the redevelopment of single-story structures that are not historically significant resources with housing and mixed use development;
14. Protect and enhance historically and architecturally significant buildings by ensuring that new development and alterations complement their existing architectural character;
15. Encourage the establishment and survival of small, locally-owned businesses, thereby contributing to the vitality and diversity of the district;
16. Discourage the type of commercial use whose establishment will contribute to the displacement of businesses that supply neighboring residents with essential goods and services;
17. Ensure that new buildings, additions and renovations harmonize with and enhance the unique character of the district;
18. Provide environmental protection for the residents of mixed residential commercial structures and surrounding residents from such detriments as noise, fumes and litter;
19. Preserve the ethnic diversity of the resident population and users of the district and of the types of businesses providing ethnically diverse goods and services in the district;
20. Protect and encourage the development of properties accessible to the disabled for both residential and commercial use;
21. Discourage uses which are widely available in other shopping districts throughout the Bay Area and detract from the unique type and mix of goods and services available in the district.

B. Allowed Land Uses.

1. **General.** See Table 23.204-1: Allowed Uses in the Commercial Districts.

2. **Bar/Cocktail Lounge/Taverns.** Service of distilled alcoholic beverages in the C-T district is allowed only when incidental to seated food service.
3. **Drug Paraphrenia Stores.** Any use involving the sale or distribution of drug paraphrenia is not permitted in the C-T district.
4. **Fuel Stations.** Alternative fuel and gasoline stations are allowed with Use Permit when located in a parking structure.
5. **Residential-Only Buildings.** Residential-only buildings are not permitted in the C-T district. Dwelling units and group living accommodations are allowed only above the ground floor in a mixed-use building.
6. **Office Uses.**
 - a. Table 23.204-31 shows permits required for office uses in the C-T district.

TABLE 23.204-31: C-T OFFICE PERMIT REQUIREMENTS

| Building Location | Permit Required | |
|------------------------------|-------------------------------|--------------------|
| | First and Second Story | Above Second Story |
| Adjacent to Bancroft Way | As required by Table 23.204-1 | AUP |
| Not adjacent to Bancroft Way | | UP(PH) |

- b. When office uses are located on the ground floor adjacent to street frontage, the storefront windows must either:
 - i.* Include a window display; or
 - ii.* Be transparent and provide pedestrian viewing at least 10 feet into the storefront area.
7. **Upper Story Uses.**
 - a. Floor area above the ground floor may be occupied only by a residential or office uses.
 - b. A commercial use that is an integral part of a ground floor establishment is permitted on the second story if the use:
 - i.* Has no entrances or exits, other than required fire exits, outside of the ground floor space; and
 - ii.* Does not exceed the ground-floor area of the use.

C. **Additional Permit Requirements.** See Section 23.204.030 (Additional Permit Requirements).

D. **Development Standards.**

1. **Basic Standards.** See Table 23.204-32: C-T Development Standards.

TABLE 23.204-32: C-T DEVELOPMENT STANDARDS

| BASIC STANDARDS | | SUPPLEMENTAL STANDARDS |
|---|----------------------|-------------------------------|
| Lot Area Minimum | | 23.304.020– Lot Requirements |
| New Lots | No minimum | |
| Per Group Living Accommodation Resident | 350 sq. ft. [1] | |
| Usable Open, Minimum | | 23.304.090– Usable Open Space |
| Space Per Dwelling Unit | 40 sq. ft. [4] | |
| Per Group Living Accommodation Resident | No minimum | |
| Floor Area Ratio, Maximum | | |
| South of Dwight Way | 4.0 | |
| North of Dwight Way | 5.0 [2] | |
| Telegraph/Channing Parking Garage [3] | No maximum | |
| Main Building Height, Minimum | 35 ft. | |
| Main Building Height, Maximum | | 23.304.050– Building Height |
| South of Dwight Way | 50 ft. [2] | |
| North of Dwight Way | 65 ft. [2] | |
| Telegraph/Channing Parking Garage [3] | 85 ft. and 7 stories | |
| Lot Line Setbacks, Minimum | | 23.304.030– Setbacks |
| Abutting/Confronting a Non-residential District | No minimum | |
| Abutting/Confronting a Residential District | See 23.304.030.C.2 | |

| | | |
|---|------------|---|
| Building Separation, Minimum | No minimum | 23.304.040– Building Separation in Residential Districts |
| Lot Coverage, Maximum | 100% | 23.304.120– Lot Coverage |
| Notes: [1] One additional resident is allowed for remaining lot area between 200 and 350 square feet. [2] Increased FAR and height allowed with Use Permit. See Table 23.204-33. [3] APN 55-1879-6-1. [4] No dimension may be less than 6 feet. | | |

2. **Lots Abutting or Confronting a Residential District.** See 23.304.130 (Non-residential Districts Abutting a Residential District) for additional building feature requirements for lots that abut or confront a Residential District.

3. **Increased Group Living Density.**

- a. Projects with group living accommodations occupying 50 percent or more of the total building floor area are eligible for increased density.
- b. To approve a Use Permit to increase the density of a group living accommodation the ZAB must make the following findings:
 - i. The increase in density will not be detrimental to the immediate neighborhood; and
 - ii. The project meets the purposes of the district.

4. **Height and FAR Increases.**

- a. Projects with 50 percent or more of the total building floor area for residential use are eligible for increased building height and FAR as shown in Table 23.204-33.

TABLE 23.204-33: C-T ALLOWED HEIGHT AND FAR INCREASES

| Project Location | Allowed Increase | |
|---------------------|----------------------|---------------------|
| | Height | FAR |
| South of Dwight Way | 65 ft. and 5 stories | No increase allowed |
| North of Dwight Way | 75 ft. and 6 stories | 6.0 |

- b. The ZAB may allow the increased height and FAR with a Use Permit upon finding that the project will not result in a significant reduction in sunlight on Telegraph Avenue sidewalks.

5. Shade Studies.

- a. A shade study is required for all proposed buildings exceeding three stories or 40 feet.
- b. Based on the findings of the shade study, the ZAB may require the fourth or higher story of a building to be set back to minimize shade impacts on adjacent properties or the public right-of-way.

6. Environmental Impacts. Projects that may create environmental impacts as described in the Southside Plan Final EIR shall be subject to the adopted Mitigation Monitoring Program (MMP).

E. Permit Findings. To approve an AUP or Use Permit for a project in the C-T district, the review authority must make the findings in Section 23.406.040 (Use Permits) and find that the proposed use or structure:

1. Is compatible with the purposes of the district;
2. Encourages and maintains the present street frontage of the district;
3. Does not interfere with the continuity of retail or compatible service facilities at the ground level;
4. Does not interrupt a continuous wall of building facades;
5. Is compatible in design and character with the district and the adjacent residential neighborhoods;
6. Does not generate traffic or parking demand significantly beyond the capacity of the district or significantly increase impacts on adjacent residential neighborhoods; and
7. Complies with the Southside Plan's adopted Mitigation Monitoring Program (MMP).

23.204.120 – C-SO Solano Avenue Commercial District

A. District Purpose. The purpose of the Solano Avenue Commercial (C-SO) district is to:

1. Implement the General Plan's designations for Community Commercial and Commercial Service areas;
2. Maintain a scale and balance of commercial activity on Solano Avenue that will:

- a. Enhance the surrounding neighborhood and serve its residents;
- b. Encourage the location of businesses on Solano Avenue that serve the everyday needs of local residents;
- c. Discourage the location of businesses on Solano Avenue that serve a larger regional clientele, and should more appropriately be located in the Central Business District;
- d. Limit the number of businesses on Solano Avenue that generate traffic or parking demand in excess of commercial parking availability, causing the overflow of traffic circulation and parking onto adjacent residential streets;
- e. Encourage location of late night commerce in appropriate areas in Berkeley, such as the downtown area, and allow businesses to address demand for late night service on Solano Avenue by establishing a 11:00 p.m. closing time for businesses on Solano Avenue; and
- f. Ensure that all construction, alterations, or additions to buildings will be in functional and aesthetic harmony with adjacent buildings and areas; and
- g. Protect local residents from commercial noise, offensive odors and parking and traffic problems.

B. Allowed Land Uses.

- 1. **General.** See Table 23.204-1: Allowed Uses in the Commercial Districts.
- 2. **Automatic Teller Machines (ATM).** A maximum of two exterior ATMs are allowed per bank establishment and only when off-street parking is provided.

C. Additional Permit Requirements. See Section 23.204.030 (Additional Permit Requirements).

D. Development Standards.

- 1. **Basic Standards.** See
- 2. Table 23.204-34: C-SO Development Standards. For residential-only projects, see also
- 3. Table 23.204-35: C-SO Setback and Building Separation Standards for Residential-Only Uses and Table 23.204-36: C-SO Lot Coverage Standards for Residential-Only Uses.

TABLE 23.204-34: C-SO DEVELOPMENT STANDARDS

| | Project Land Use | | | Supplemental Standards |
|---|-------------------------------|---------------------|----------------------|--|
| | Non-Residential and Mixed Use | Mixed-Use [1] | Residential Only [1] | |
| Lot Area, Minimum | | | | |
| New Lots | No minimum | | 5,000 sq. ft | 23.304.020– Lot Requirements |
| Per Group Living Accommodation Resident | 350 sq. ft. [2] | | | |
| Usable Open Space, Minimum | | | | 23.304.090– Usable Open Space |
| Per Dwelling Unit | 40 sq. ft. [4] | 200 sq. ft. | | |
| Per Group Living Accommodation Resident | No minimum | 90 sq. ft. | | |
| Floor Area Ratio, Maximum | 2.0 | No maximum | | |
| Main Building Height, Minimum | No minimum | | | |
| Main Building Height, Maximum | 28 ft. and 2 stories | | | 23.304.050– Building Height |
| Lot Line Setbacks, Minimum | | | | 23.304.030– Setbacks |
| Abutting/Confronting a Non-residential District | No minimum | See Table 23.204-35 | | |
| Abutting/Confronting a Residential District | See 23.304.030.C.2 | | | |
| Building Separation, Minimum | No minimum [3] | See Table 23.204-35 | | 23.304.040– Building Separation in Residential Districts |
| Lot Coverage, Maximum | 100% | See Table 23.204-36 | | 23.304.120– Lot Coverage |

| | Project Land Use | | | Supplemental Standards |
|--|-------------------------------|---------------|----------------------|------------------------|
| | Non-Residential and Mixed Use | Mixed-Use [1] | Residential Only [1] | |

Notes-

[1] For mixed use and residential only projects, development standards included in this table may be modified. See 23.204.120.D.2.

[2] One additional resident is allowed for remaining lot area between 200 and 350 square feet.

[3] For mixed-use projects, minimum building separation shall be as required for residential-only projects

[4] No dimension may be less than 6 feet.

TABLE 23.204-35: C-SO SETBACK AND BUILDING SEPARATION STANDARDS FOR RESIDENTIAL-ONLY USES

| | STANDARDS BY BUILDING STORY | | | SUPPLEMENTAL STANDARDS |
|----------------------------------|-----------------------------|--------|--------|--|
| | 1ST | 2ND | 3RD | |
| Lot Line Setbacks, Minimum [1] | | | | 23.304.030– Setbacks |
| Front | 15 ft. | 15 ft. | 15 ft. | |
| Rear | 15 ft. | 15 ft. | 15 ft. | |
| Interior | 4 ft. | 4 ft. | 6 ft. | |
| Street Side | 6 ft. | 8 ft. | 10 ft. | 23.304.040– Building Separation in Residential Districts |
| Building Separation, Minimum [1] | 8 ft. | 12 ft. | 16 ft. | |

[1] For mixed use and residential-only projects, development standards included in this table may be modified. See 23.204.120.D.2.

TABLE 23.204-36: C-SO LOT COVERAGE STANDARDS FOR RESIDENTIAL-ONLY USES

| | STANDARD BASED ON BUILDING HEIGHT | | | SUPPLEMENTAL STANDARDS |
|---------------------------|-----------------------------------|-----------|-----------|--------------------------|
| | 1 STORY | 2 STORIES | 3 STORIES | |
| Lot Coverage, Maximum [1] | | | | 23.304.120– Lot Coverage |
| Interior and Through Lots | 45% | 45% | 40% | |

| | | | | |
|--|-----|-----|-----|--|
| Corner Lots | 50% | 50% | 45% | |
| [1] For mixed use and residential-only projects, development standards included in this table may be modified. See 23.204.120.D.2. | | | | |

1. **Lots Abutting or Confronting a Residential District.** See 23.304.130 (Non-residential Districts Abutting a Residential District) for additional building feature requirements for lots that abut or confront a Residential District.
2. **Modification to Standards –Mixed Use and Residential-Only Projects.** The ZAB may modify development standards in
3. Table 23.204-34,
4. Table 23.204-35, and Table 23.204-36 for a mixed-use or residential-only project with a Use Permit upon making one of the following findings:
 - a. The modification will encourage public transit utilization and existing off-street parking facilities in the area of the proposed building.
 - b. The modification will facilitate the construction of residential or tourist hotel uses where appropriate.
 - c. The modification will permit consistency with the building setbacks existing in the immediate area where a residential building setback would not serve a useful purpose.
5. **Ground Floor Residential Uses.** A ground floor residential uses shall be setback at least 320 feet from a street side property line.
6. **Projections into Right-of-Way.**
 - a. Bay windows and balconies 11 feet or more above the sidewalk grade may project 3 feet into a street right-of-way.
 - b. A maximum 60 percent of the length of a building frontage may project beyond the property line.
 - c. All projections require an encroachment permit from the Public Works Department.
7. **Limitations Adjacent to a R District.** The following requirements apply to commercial uses adjacent to a residential district or fronting any street other than Solano Avenue.
 - a. All openings other than fixed windows and required fire exits must be setback at least 50 feet from any property located in an Residential District to reduce noise and odor problems in residential areas

- b. Customer use of rear or side exits which open onto residential streets (with the exception of emergency access) is not permitted.
- c. Garbage and recycled materials may not be placed for collection on residential streets from storage areas located at the rear of any building. All such materials shall be stored in an enclosed area for health and sanitation reasons.
- d. Deliveries to non-residential establishments from residential streets are not permitted.

E. Permit Findings. To approve an AUP or Use Permit for a project in the C-SO district, the review authority must make the findings in Section 23.406.040 (Use Permits) and find that the proposed use or structure:

- 1. Encourages and maintains the character of the street frontage and pedestrian orientation of the district;
- 2. Is compatible in design and character with the district and the adjacent residential neighborhood;
- 3. Is compatible with the purposes set forth in this set of regulations and the existing character of Solano Avenue;
- 4. Does not interfere with the continuity of retail or compatible service facilities at the ground level, or interrupt a continuous wall of building facades; and
- 5. Does not generate traffic and parking demand to significantly increase impacts on adjacent residential neighborhoods.

23.204.130 – C-DMU Downtown Mixed-Use District

A. District Purpose. The purpose of the C-DMU district is to implement the vision and goals of the Downtown Area Plan (adopted 2012), which include: Environmental Sustainability, Land Use, Access, Historic Preservation and Urban Design, Streets and Open Space, Housing and Community Health and Services, and Economic Development.

B. Allowed Land Use.

- 1. **General.** See Table 23.204-1: Allowed Uses in the Commercial Districts.
- 2. **Automatic Teller Machines (ATM).** An ATM inside a non-bank building is allowed with an AUP.
- 3. **Banks and Financial Services, Retail.** Retail banks and financial services in the C-DMU require permits as follows:

FIGURE 23.204-4: C-DMU DOWNTOWN ARTS DISTRICT OVERLAY BOUNDARIES

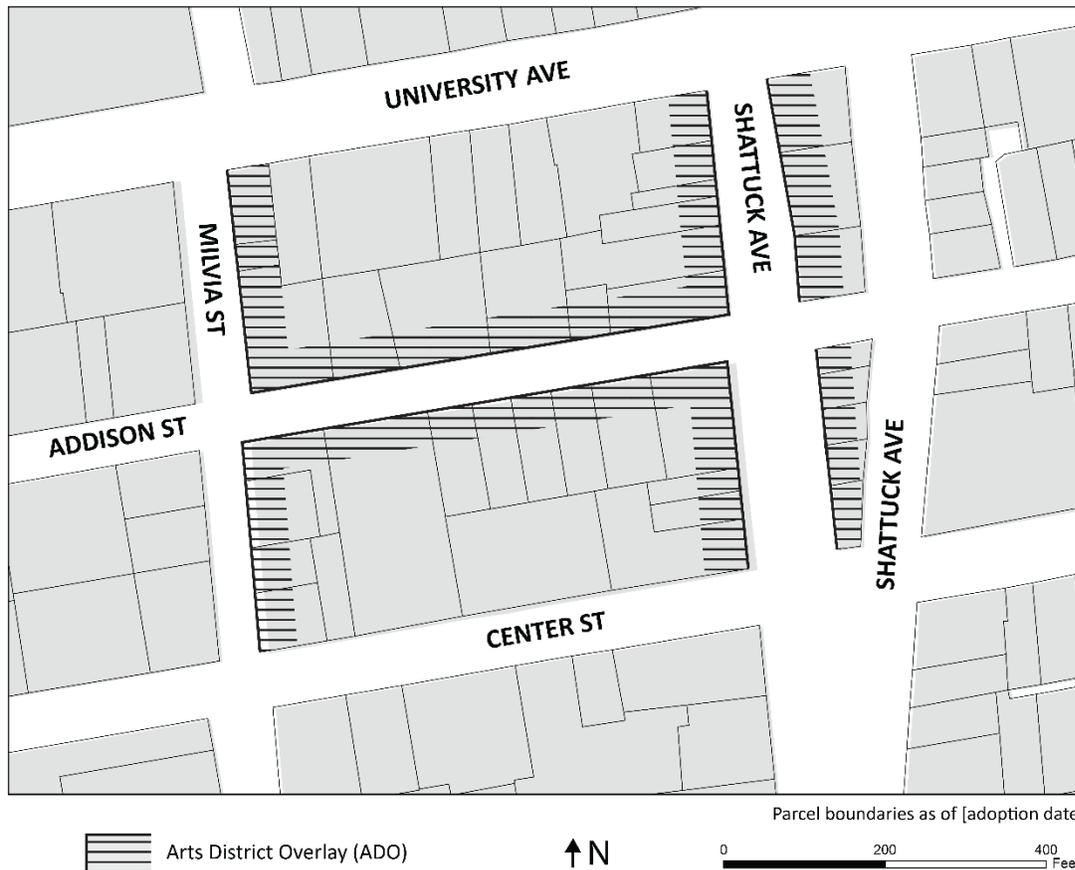

3. **Use Limitations; Findings.** Food service establishments and offices on the ground floor adjacent to a street frontage require an AUP. To approve the AUP, the Zoning Officer must find that
 - a. The project meets the purposes of the Arts Overlay District as set forth above; and
 - b. The location, size, type, appearance, and signage of the proposed use will:
 - i.* Animate and enhance the pedestrian experience on the street; and
 - ii.* Be generally open to the public evenings and on weekends, whenever practicable.

E. Development Standards.

1. Height.

- a. **Height Limits.** Table 23.204-37: C-DMU Height Limits shows height limits in the C-DMU district, except as otherwise allowed by Paragraph 2 below. See Figure 23.204-5: C-DMU Sub-Areas for district sub-area boundaries.

TABLE 23.204-37: C-DMU HEIGHT LIMITS

| SUB-AREA | MINIMUM | MAXIMUM | MAXIMUM WITH USE PERMIT |
|------------|------------|---------|-------------------------|
| Core Area | 50 ft. | 60 ft. | 75 ft. |
| Outer Core | 40 ft. | | |
| Corridor | 40 ft. | | |
| Buffer | No minimum | 50 ft. | 60 ft. |

- b. **Parapet Walls.** For roofs with parapet walls, building height is measured to the top of the roof. Parapets may exceed the height limit by up to 5 feet as of right.
- c. **Minimum Height.** The minimum height standard applies to new buildings only, measured to the top of the plate. Theater and museum buildings are exempt.

2. Increased Height Allowance.

- a. **Allowed Height.** The ZAB may issue a Use Permit for up to five buildings that exceed the C-DMU height limits as shown in Table 23.204-38: C-DMU Increased Height Allowance.

TABLE 23.204-38: C-DMU INCREASED HEIGHT ALLOWANCE

| Sub-Area | Number of Buildings | Height | |
|------------------------------|---------------------|---------|---------|
| | | Minimum | Maximum |
| Combined Core and Outer Core | 2 | 75 ft. | 120 ft. |
| Core | 3 | 120 ft. | 180 ft. |

- b. **Application Process.**
 - i. Applications for any of the five buildings over 75 feet in height may be submitted on July 1, 2012. If no applications that satisfy the submittal requirements as determined by the Zoning Officer are submitted on that date, then the next deadline to submit applications will be no later than six months from that date, with application opportunity dates at six-month intervals until the first application has been submitted. Once the first

application has been submitted, then the application opportunity date will occur once yearly on the anniversary of the date of the first submittal.

- ii.* A project shall secure a position as one of the five allowed buildings over 75 feet in height following final Use Permit approval. Such Use Permits shall include a condition of approval that establishes a schedule for: submittal of a building permit application, timely response to plan check comments, payment of building permit fees such that a building permit can be issued, and beginning construction. The process for allowing extension of the timeline requirements, if any, shall be specified in the condition.
- iii.* Failure of a permit holder to strictly comply with the schedule established by the Use Permit is grounds for revocation of the Use Permit pursuant to Chapter 23.404.080 (Permit Revocation).

c. Community Benefit Required.

- i.* To approve a Use Permit for increased building height under this section, the ZAB must find that the project will provide significant community benefits, either directly or by providing funding for such benefits to the satisfaction of the City, beyond what would otherwise be required by the City.
- ii.* Significant community benefits may include, but are not limited to affordable housing, supportive social services, green features, open space, transportation demand management features, job training, and/or employment opportunities.
- iii.* This community benefit requirements shall be included as conditions of approval and the owner shall enter into a written agreement with the City that shall be binding on all successors in interest.

3. Setbacks.

Basic Standards. Table 23.204-39 shows minimum required lot line setbacks in the C-DMU district. Additional standards are listed in 23.204.130.3.d.

TABLE 23.204-39:C-DMU SETBACK STANDARDS

| PORTION OF BUILDING AT HEIGHT OF: | FRONT OR STREET SIDE | MINIMUM INTERIOR SIDE | | MINIMUM REAR |
|-----------------------------------|------------------------|--------------------------------|----------------------------|--------------|
| | | 65' AND LESS FROM LOT FRONTAGE | OVER 65' FROM LOT FRONTAGE | |
| Zero to 20 feet | No minimum. 5 ft. max. | No minimum | | |

| | | | |
|---------------------|-------------|------------|--------|
| 21 feet to 75 feet | No minimum. | No minimum | 5 ft. |
| 76 feet to 120 feet | 15 ft. min. | 5 ft. | 15 ft. |
| Over 120 feet | 15 ft. min. | 15 ft. | |

- a. **Modifications to Standards.** The ZAB may modify the setback standards in Table 23.204-39 with a Use Permit upon finding that the modified setbacks will not unreasonably limit solar access or create significant increases in wind experienced on the public sidewalk.
- b. **Residential Transitions.** The setback standards in Table 23.204-39 shall not apply to commercial lots abutting or confronting residential zoning. Such lots shall comply with Section 23.304.030.C.2– Setbacks (Lots Adjacent to Residential Districts).
- c. **Additional Standards.**
 - i. For buildings over 120 feet in height, that portion of the building over 120 feet must be less than 120 feet in width when measured at the widest point on the diagonal in plan view.
 - ii. For a lot that abuts the interior side or rear lot line of a residentially-zoned lot, a new building shall be set back from the shared property line by 20 feet where the building exceeds 45 feet in height.
 - iii. For a lot that confronts a residentially-zoned lot, a new building shall be set back 10 feet from the street-facing property line where the building exceeds 45 feet in height, except that this provision shall not apply to lots confronting public uses with a residential zoning designation, such as Berkeley High School, Civic Center Park, and Fire Station 2. However, this provision will apply for all lots with frontage on the Martin Luther King Jr. Way right-of-way.
 - iv. For lots with frontage on the Shattuck Avenue right-of-way south of Durant Avenue, a new building shall be set back 15 feet from the Shattuck Avenue property line where the building exceeds 65 feet in height.
 - v. Architectural features such as eaves, cornices, canopies, awnings, bay windows, uncovered porches, balconies, fire escapes, stairs and landings may project up to five feet into required setbacks of this section so long as the surface area of such projections does not exceed 50 percent of the surface area of the side of the building on which the projections are located.

4. **Usable Open Space.** Table 23.204-40 shows minimum required usable open space in the C-DMU district.

TABLE 23.204-40: C-DMU USABLE OPEN SPACE REQUIREMENTS

| | MINIMUM USABLE OPEN SPACE |
|---|---|
| Residential Uses | 80 sq. ft./unit [1] |
| Non-Residential Uses | 1 sq. ft. of privately-owned public open space per 50 sq. ft. of commercial floor area. |
| <p>Note: [1] Each square foot of usable open space provided as privately-owned public open space is counted as two square feet of required on-site open space.</p> | |

5. Privately-Owned Public Open Space.

- a. If a privately-owned public open space is indoors or enclosed, it shall include natural light in the form of windows, skylights, entryways, or other openings.
- b. Privately-owned public open space must be:
 - i. Clearly identified with signage in a publicly conspicuous location at street level indicating the area that is open to the public, the hours the space is open, and the party responsible for maintenance; and
 - ii. Separated from the grade of the public sidewalk by a height no greater than 3 vertical feet unless an AUP is obtained.

6. Open Space Alternatives.

- a. In lieu of providing the open space required by this section on-site, an applicant may either:
 - i. Pay an in-lieu fee to help fund the Streets and Open Space Improvement Plan (SOSIP); and/or
 - ii. Construct public improvement consistent with the SOSIP.
- b. To allow payment of in-lieu fee, the ZAB must find that the payment will support timely development of open space improvements that will serve the needs of both project residents and other people living in and using the downtown.
- c. To allow construction of public improvements, the ZAB must find that the public improvements:

- i.* Will be located within the vicinity of the project and are consistent with the SOSIP;
- ii.* Will be coordinated with other ongoing or approved SOSIP or other right-of-way improvements in the vicinity, and will not create a hazardous situation or an unusual appearance in the downtown; and
- iii.* Will be finished before issuance of a certificate of occupancy for the project, unless otherwise allowed by the project conditions of approval.

7. Ground Floor Street Frontage.

- a. Special ground floor street frontage requirements in Paragraph (b) below apply to the following uses in the C-DMU district:
 - i.* Insurance Agents, Title Companies, Real Estate Agents, Travel Agents
 - ii.* Office, Business and Professional
 - iii.* Group Class Instruction
 - iv.* Gym/Health Club
- b. New ground floor uses listed in paragraph (a) above that are adjacent to a street frontage shall either:
 - i.* Include a storefront window display; or
 - ii.* Be transparent and provide pedestrian viewing at least 10 feet into the storefront area.

- 8. Residential Entrance Limitations.** In new buildings constructed on public serving frontages, as shown in Figure 23.204-6, entrances to individual dwelling units and to living quarters in group living accommodations are not permitted on the street-facing side of the street-level floor.

FIGURE 23.204-6: C-DMU PUBLIC SERVING FRONTAGES



 Public-Serving Frontage Required

Parcel boundaries as of [adoption date]

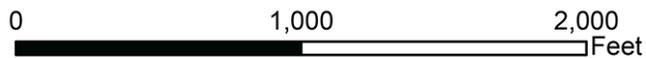

F. **Streets and Open Space Improvement Plan (SOSIP) Fee.** In addition to any other requirement of this section, projects shall be subject to payment of an impact fee to implement the Streets and Open Space Improvement Plan.

G. **Green Building Provisions.**

1. **New Buildings.** Construction of any new building shall attain either:
 - a. LEED Gold rating or higher as defined by the U.S. Green Building Council (USGBC); or
 - b. Building performance equivalent to this rating, as determined by the Zoning Officer.
2. **Additions 20,000 Square Feet or Less.** Additions of 20,000 square feet or less shall be required to meet all applicable standards of the Stopwaste Small Commercial Checklist, or equivalent, as determined by the Zoning Officer. The rating shall be appropriate to the use type of the proposed construction.
3. **Additions More than 20,000 Square Feet.** Additions of more than 20,000 square feet shall attain either:
 - a. LEED Gold rating or higher as defined by the U.S. Green Building Council (USGBC); or
 - b. Building performance equivalent to this rating, as determined by the Zoning Officer.

H. **Environmental Impacts.** Projects that may create potentially significant environmental impacts as described in the Downtown Area Plan Final EIR shall be subject to the adopted Mitigation Monitoring Program for the Downtown Area Plan.

I. **Permit Findings.** To approve an AUP or Use Permit for a project in the C-DMU district, the review authority must make the findings in Section 23.406.040 (Use Permits) and find that the proposed use or structure:

1. Is compatible with the purposes of the district; and
2. Is compatible with the surrounding uses and buildings.

23.204.140 – C-W West Berkeley Commercial District

A. **District Purpose.** The purpose of the West Berkeley Commercial (C-W) district is to:

1. Implement the West Berkeley Plan Commercial District designation;
2. Provide locations for commercial services which primarily serve area residents and/or businesses;
3. Support the retention and attraction of a balance of both smaller and larger stores and restaurants;
4. Provide appropriate locations, consistent with West Berkeley Plan policies, for commercial services which serve a citywide or broader clientele;
5. Provide a relatively compact, clearly bounded set of commercial areas in West Berkeley, so as to both improve the quality of West Berkeley shopping environments and to prevent commercial overspill into industrial areas;
6. Encourage the intensification of commercial activity at designated nodes to help develop more pedestrian-oriented environments at those locations;
7. Increase the opportunities for development of housing in commercial areas to support local retailing and use of transit lines and opportunities for mixed use projects combining pedestrian-oriented neighborhood-serving uses with mixed income housing in locations abutting residential districts;
8. Encourage appropriately intense development in underutilized portions of commercial streets;
9. Promote development compatible with adjacent commercial, residential and industrial areas;
10. Provide a location for cultural and performing arts activities; and
11. promote environmental protection for the residents and workers both within and adjacent to the district from such detriments as noise, fumes, and other detrimental environmental effects.

B. **Land Use Regulations.**

1. **General.** See Table 23.204-1: Allowed Uses in the Commercial Districts.
2. **Mixed-Use Residential.**
 - a. See Table 23.204-41 for mixed-use residential permit requirements in the C-W district.

TABLE 23.204-41: C-W MIXED-USE RESIDENTIAL PERMIT REQUIREMENTS

| Total Project Floor Area | Permit Required |
|--|-----------------|
| Projects with both residential and retail uses where the retail space comprises 15% to 33% of total gross floor area | |
| Less than 20,000 square feet | ZC |
| 20,000 square feet or more | UP(PH) |
| All other mixed-use residential projects | |
| Less than 5,000 square feet | ZC |
| 5,000 to 9,000 square feet | AUP |
| More than 9,000 square feet | UP(PH) |

- b. All new retail uses in an existing mixed-use development are subject to the permit requirements for mixed use development as shown in Table 23.204-41.

3. Automotive Uses.

- a. As used in this paragraph, “automotive use” means a use classified in Table Table 23.204-1 as a vehicle service and sales use. “Automotive site” means a site which was legally used or approved for use as an automotive use as of March 1, 1997.
- b. On lots in the C-W district with frontage on San Pablo Avenue:
 - i. An automotive use may be established only on an automotive site; and
 - ii. If an automotive use on an automotive site is discontinued for a period of two years or more, it may not be re-established.

4. Langendorf Building. See Section 23.206.030.D– Additional Permit Requirements (Langendorf Building).

C. Additional Permit Requirements. See Section 23.204.030– Additional Permit Requirements.

D. Designated Nodes.

- 1. **Purpose.** The purposes of the designated nodes in the C-W district are to:
 - a. Intensify retail, commercial, and mixed-use activity around major intersections;

- b. Reflect and reinforce the major existing and developing concentrations of pedestrian-oriented uses;
 - c. Encourage intensified development around transit transfer points;
 - d. Help define the urban form of San Pablo Avenue by developing identifiable areas of concentrated development.
2. **Location.** Properties designated as nodes in the C-W district are shown in Figure 23.204-7: C-W Designated Nodes.
3. **Ground Floor Uses.** The ground floor of buildings in designated nodes may be used only for the following:
- a. Retail sales
 - b. Personal and household services
 - c. Retail financial services (banks)
 - d. Food and alcohol service
 - e. Lodging
 - f. Entertainment and assembly uses
 - g. Gasoline/vehicle fuel stations
 - h. Vehicle repair uses
 - i. New car sales
 - j. Used vehicles sales
 - k. Required access to and lobbies serving upper-story uses
4. **Prohibited Uses.** The following uses are not permitted in designated nodes:
- a. Vehicle rentals
 - b. Used vehicle sales when not principally in buildings
 - c. Vehicle washes
 - d. Tire sales and service
 - e. Open air markets
 - f. Circus/carnivals
 - g. Public utility substation buildings, tanks
5. **Findings.** To approve a Use Permit or AUP for a project in a designated node, the review authority must find that the project supports the development of a

strong retail commercial and pedestrian-oriented environment at the node.

Factors the review authority should consider when making this finding include:

- a. The placement of store entrances relative to the street and parking lots; and
- b. The size and prominence of display windows and areas facing the sidewalk.

FIGURE 23.204-7: C-W DESIGNATED NODES



West Berkeley Commercial (C-W)
 Node 1: Gillman and San Pablo
 Parcel boundaries as of [adoption date]



West Berkeley Commercial (C-W)
 Node 2: Cedar and San Pablo
 Parcel boundaries as of [adoption date]



West Berkeley Commercial (C-W)
 Node 3: University and San Pablo
 Parcel boundaries as of [adoption date]



West Berkeley Commercial (C-W)
 Node 4: Dwight and San Pablo
 Parcel boundaries as of [adoption date]

FIGURE 23.204-8: C-W DESIGNATED NODES

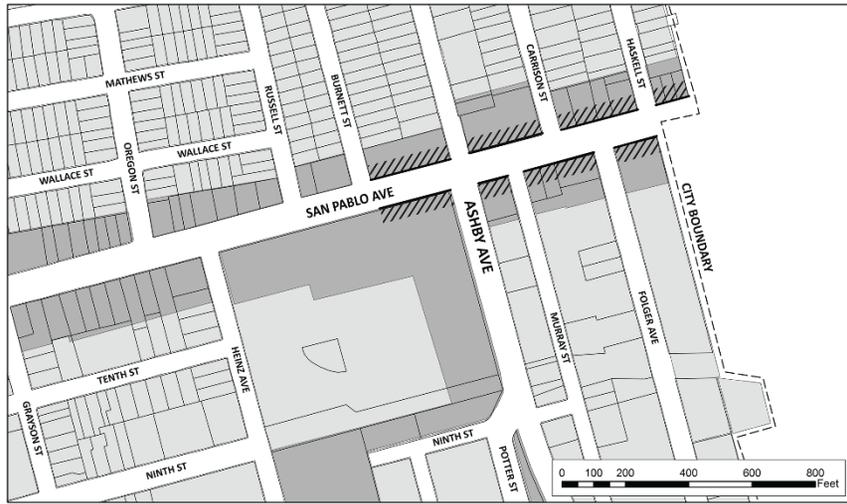

← N
 West Berkeley Commercial (C-W)
 Node 5: Ashby and San Pablo
 Parcel boundaries as of [adoption date]

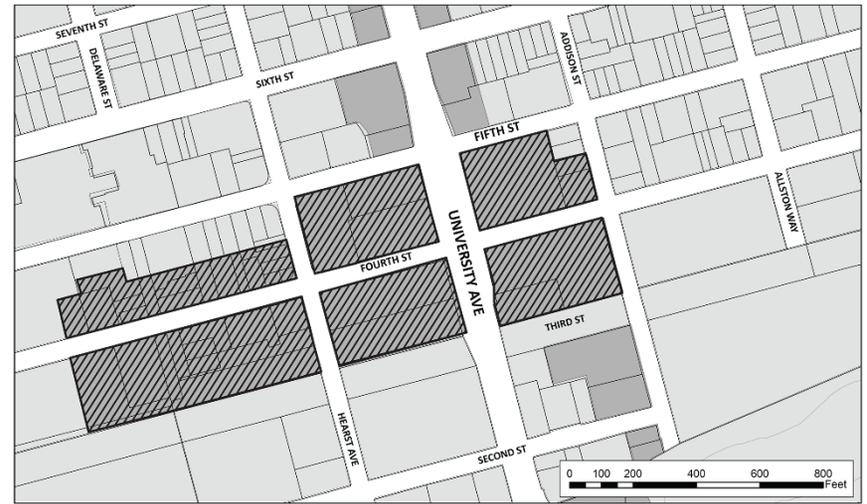

← N
 West Berkeley Commercial (C-W)
 Node 6: 4th Street and University
 Parcel boundaries as of [adoption date]

E. Development Standards.

- 1. Basic Standards.** See Table 23.204-42 for development standards in the C-W district.

TABLE 23.204-42: C-W DEVELOPMENT STANDARDS

| BASIC STANDARDS | | SUPPLEMENTAL STANDARDS |
|--|----------------------------|-------------------------------|
| Lot Area Minimum | | 23.304.020– Lot Requirements |
| New Lots | No minimum | |
| Per Group Living Accommodation Resident | 350 sq. ft. | |
| Usable Open Space, Minimum | | 23.304.090– Usable Open Space |
| Per Dwelling Unit or Live/Work Unit | 40 sq. ft. | |
| Per Group Living Accommodation Resident | No minimum | |
| Floor Area Ratio, Maximum | 3.0 | |
| Main Building Height, Minimum | No minimum | |
| Main Building Height, Maximum | 40 ft. and 3 stories [1,2] | 23.304.050– Building Height |
| Lot Line Setbacks, Minimum | | 23.304.030– Setbacks |
| Abutting/Confronting a Non-residential District | No minimum | |
| Abutting/Confronting a Residential District | See 23.304.030.C.2 | |
| Building Separation, Minimum | No minimum | |
| Lot Coverage, Maximum | 100% | 23.304.120– Lot Coverage |
| <p>Notes:</p> <p>[1] 50 ft. and 4 stories allowed for mixed-use projects. The fourth floor must be used for residential or live/work purposes.</p> <p>[2] On Assessor Parcel Numbers 054-1763-001-03, 054-1763-010-00 and 054-1763-003-03 the maximum height is 50 feet and 4 stories.</p> | | |

- 2. Parking Lot Design.** See 23.322.080.E.3 (C-W District).

3. **Minimum Height in Designated Nodes.** All newly constructed main structures in designated nodes, except gasoline stations, shall be at least two stories or 25 feet in height.

F. **Permit Findings.** To approve an AUP or Use Permit for a project in the C-W district, the review authority must make the findings in Section 23.406.040 (Use Permits) and find that the proposed use or structure:

1. Is consistent with the purposes of the district;
2. Is compatible with the surrounding uses and buildings;
3. Complies with the adopted West Berkeley Plan;
4. Supports an increase in the continuity of retail and service facilities at the ground level to the degree feasible;
5. Does not substantially degrade the existing urban fabric of the street and area;
6. Provides an intensity of development which does not underutilize the property (for with new floor area);
7. Meets any applicable performance standards for off-site impacts; and
8. Does not exceed the amount and intensity of use that can be served by available traffic capacity and potential parking supply.

23.204.150 – C-AC Adeline Corridor Commercial District

A. **District Purpose.** The purpose of the Adeline Corridor Commercial (C-AC) district is to:

1. Implement the General Plan's designation for Adeline Corridor Mixed Use area, as well as the policies of the Adeline Corridor Specific Plan;
2. Preserve the unique character and cultural legacy of the Adeline Corridor, sustaining the community as a place where all people can live, work, play, learn, worship, dine, shop and thrive;
3. Promote equitable access to housing by preserving existing affordable housing, preventing displacement, and producing a substantial number of new affordable housing units;
4. Foster economic opportunity for South Berkeley residents and businesses by facilitating job training and workforce development, active community spaces, and a thriving environment for commerce along the Adeline Street/South Shattuck Corridor;

5. Provide safe, equitable transportation options that meet the mobility needs of all residents, regardless of age, means and abilities, and that further the attainment of greenhouse gas emission reduction goals;
6. Provide safe, sustainable, beautiful, healthy, and inclusive public spaces that encourage social interaction, provide opportunities for recreation and environmental health, and support active community life in South Berkeley;
7. Encourage development and amenities that support pedestrian-oriented uses; and
8. Maintain and encourage a wide range of community and commercial services, including basic goods and services. Provide locations for both community-serving and regional-serving: businesses, cultural and religious institutions, and non-profit organizations.

B. Allowed Land Uses.

1. **General.** See Table 23.204-1: Allowed Uses in the Commercial Districts.
2. **Mixed Use Buildings.**
 - a. In all mixed use buildings, all stories above the second story shall be used for residential uses.
 - b. All mixed use developments require a Use Permit.
3. **Permitted Ground Floor Uses.**
 - a. **Commercial and Active Commercial Required.** In addition to other requirements of the C-AC district, the first 30 feet of depth of the ground floor, as measured from the frontage which abuts the portions of Adeline Street, Shattuck Avenue, MLK, Jr. Way or Ashby Avenue identified in Table 23.204-43: C-AC Permitted Ground Floor Uses shall be reserved for either Active Commercial Uses, or for commercial uses. Ground floor tenant spaces with frontages on streets not identified below can be used for any use permitted in the district.

TABLE 23.204-43: C-AC PERMITTED GROUND FLOOR USES

| AREA | PERMITTED GROUND FLOOR USE |
|---|----------------------------|
| Shattuck Avenue between Dwight and Derby | Commercial Uses |
| Shattuck between Ward and Russell | Active Commercial Uses |
| Adeline between Russell and City boundary | |
| Ashby, east of Adeline | |
| North side of Ashby, west of Adeline | |

- b. **Active Commercial Uses Defined.** Active Commercial uses are commercial uses which generate regular and frequent foot traffic. Uses include businesses in the following use categories: Retail Sales; Personal and Household Services; Food and Alcohol Service, Lodging, Entertainment, and Assembly Uses; and the following uses: Banks and Financial Services, Retail, and Vehicle Parts Stores.
 - c. **Active Commercial Exceptions with Zoning Certificate.** The following uses are permitted on the ground floor in areas designated Active Commercial with a Zoning Certificate:
 - i. Office uses in tenant space 2,500 sf or less in area and 50 feet or less in width;
 - ii. Residential amenities (2,500 sf or less in area and 50 feet or less in width), associated with a residential use.
 - d. **Active Commercial Exceptions with AUP.** The following uses are permitted on the ground floor in areas designated Active Commercial with an AUP:
 - i. Office uses over 2,500 square feet in area or 50 feet in width.
 - ii. Art/Craft Studio.
 - e. **Affordable Residential Projects Allowed.** Residential uses where at least 50 percent of the units are affordable are permitted on the ground floor in areas designated commercial with an AUP.
 - f. **Live/Work Units Prohibited.** Live/Work units are not permitted on the ground floor in areas designated Active Commercial or commercial.
4. **Alcoholic Beverage Retail Sales.** The sale of distilled alcoholic beverages is not permitted along Adeline Street, south of Ashby Avenue.
- C. **Additional Permit Requirements.** See Section 23.204.030– Additional Permit Requirements.
- D. **Adeline Corridor Specific Plan Subareas.** The Adeline Corridor Specific Plan identifies four distinct subareas which have different physical characteristics and contexts. Different use limitations and development standards may apply to these subareas. See the Adeline Corridor Specific Plan for more specific information about each subarea.
- 1. **South Shattuck:** Parcels that have a frontage abutting Shattuck Avenue.
 - 2. **North Adeline.**
 - a. West of Adeline: Parcels located between Derby Street and Ashby Avenue, which do not front Shattuck Avenue.

- b. East of Adeline: Parcels located entirely between Russell Street and the point 110 feet south of Essex Street.

3. **Ashby BART.**

- a. West of Adeline: Parcels bounded by Ashby, MLK Jr. Way and Adeline.
- b. **East of Adeline:** Parcels located entirely between Tremont, Woolsey and Adeline, and at least 110 feet south of Essex.

4. **South Adeline:** Parcels located south of Woolsey Street.

E. **Development Standards.**

- 1. **Basic Standards.** See Table 23.204-44: C-AC South Shattuck Subarea Development Standards, and

3. Table 23.204-45: C-AC North and South Adeline Subarea Development Standards.
4. **Affordability Calculation.** Development standards are based on the percentage of affordable units and shall not exceed the requirements for each subarea. The minimum on-site affordable housing requirement applies to all residential and mixed use projects and must be provided as a mix of 50 percent at Low Income and 50 percent at Very Low Area Median Income (AMI) levels.
5. **Ashby BART Subarea.** Development standards for any future development in the Ashby BART area would be subject to process outlined in the MOU with BART and AB 2923.
6. **Parapet Walls.** For roofs with parapet walls, building height is measured to the top of the roof. Parapets may exceed the height limit by up to 5 feet as of right.
7. **Lots Abutting or Confronting a Residential District.**
 - a. **Setbacks.** The following standards supersede requirements in Section 23.304.030.C.2.– Setbacks (Lots Adjacent to Residential Districts).
 - i. When a lot confronts a residentially-zoned lot, any portion of new construction that exceeds 45 feet in height shall be setback 10 feet from the front property line.
 - ii. When a lot abuts a residentially-zoned lot, the setback shall be 10 feet from the shared lot line.
 - iii. When a lot abuts a residentially-zoned lot, any portion of new construction that exceeds 35 feet in height shall be setback 20 feet from the shared lot line.
 - b. **Building Features.** See Section 23.304.130– Non-Residential Districts Abutting a Residential District for building feature requirements for lots that abut or confront a Residential District.

TABLE 23.204-44: C-AC SOUTH SHATTUCK SUBAREA DEVELOPMENT STANDARDS

| | PROJECT LAND USE [5] | | | | | | | SUPPLEMENTAL STANDARDS |
|---|---|---|---|---|---|--------------------------------|-----------------|-------------------------------|
| | Residential and Mixed Use Tier 1 (Less than 14% affordable housing) | Residential & Mixed Use Tier 2 (14% affordable housing) | Residential & Mixed Use Tier 3 (21% affordable housing) | Residential & Mixed Use Tier 4 (25% affordable housing) | Residential & Mixed Use (100% affordable housing) | Group Living Accommodation [6] | Non-Residential | |
| Lot Area Minimum | | | | | | | | 23.304.020– Lot Requirements |
| New Lots | No minimum | | | | | 350 sq. ft. | | |
| Per Group Living Accommodation Resident | N/A | | | | | 350 sq. ft. [1] | | |
| Usable Open Space, Minimum [3] | 40 sq. ft. | | | | | | | |
| Per Dwelling Unit/GLA Resident [4] | 40 sq. ft. | | | | | | | 23.304.090– Usable Open Space |
| Floor Area Ratio, Maximum | 2.5 | 4.0 | 5.0 | 5.5 | 5.5 | 2.5 | 2.5 | |

| | PROJECT LAND USE [5] | | | | | | | SUPPLEMENTAL STANDARDS |
|---|---|---|---|---|---|--|----------------------|--------------------------------|
| | Residential and Mixed Use Tier 1 (Less than 14% affordable housing) | Residential & Mixed Use Tier 2 (14% affordable housing) | Residential & Mixed Use Tier 3 (21% affordable housing) | Residential & Mixed Use Tier 4 (25% affordable housing) | Residential & Mixed Use (100% affordable housing) | Group Living Accommodation [6] | Non-Residential | |
| Main Building Height, Maximum | 4 stories 45 feet | 6 stories 65 feet | 7 stories 75 feet | 8 stories 85 feet | 8 stories 90 feet | 4 stories 45 feet | 4 stories 45 feet | 23.304.050– Building Height |
| Residential Density, Maximum (du/acre) [2] | 120 | 210 | 250 | 300 | 300 | 1 GLA resident per 350 sf of lot area | N/A | |
| Lot Line Setbacks, Minimum | | | | | | | | 23.304.030– Setbacks |
| Abutting/Confronting a Non-residential District | No minimum | | | | | | | |
| Abutting/Confronting a Residential District | See 23.204.150.G | | | | | | | |
| Building Separation, Minimum | No minimum | | | | | | | |
| Lot Coverage, Maximum | | | | | | | | 23.304.120– Lot Coverage |
| Interior Lot | 60% | 90% | 90% | 90% | 90% | 60% | 100% | |
| Corner Lot | 70% | 90% | 90% | 95% | 95% | 70% | 100% | |

| | PROJECT LAND USE [5] | | | | | | | SUPPLEMENTAL STANDARDS |
|--|---|---|---|---|---|--------------------------------|-----------------|------------------------|
| | Residential and Mixed Use Tier 1 (Less than 14% affordable housing) | Residential & Mixed Use Tier 2 (14% affordable housing) | Residential & Mixed Use Tier 3 (21% affordable housing) | Residential & Mixed Use Tier 4 (25% affordable housing) | Residential & Mixed Use (100% affordable housing) | Group Living Accommodation [6] | Non-Residential | |

- Notes:
- [1] One additional resident is allowed for remaining lot area between 200 and 350 square feet.
 - [2] For the purposes of calculating the State Density Bonus the Tier 1 density shall constitute the maximum allowable gross residential density. Tier 2, 3, and 4 density is authorized as a local density bonus under Government Code section 65915(n).
 - [3] An AUP may be granted to reduce useable open space requirements if shown to be necessary to build an all-electric building.
 - [4] Each square-foot of open space that is designated as publicly accessible open space shall be counted as two square-feet of required on-site open space.
 - [5] Affordable units calculated as percentage of total units

TABLE 23.204-45: C-AC NORTH AND SOUTH ADELINE SUBAREA DEVELOPMENT STANDARDS

| | Project Land Use [6] | | | | | | | Supplemental Standards |
|--|---|---|---|---|---|---------------------------------------|-----------------|------------------------|
| | Residential and Mixed Use Tier 1 (Less than 14% affordable housing) | Residential & Mixed Use Tier 2 (14% affordable housing) | Residential & Mixed Use Tier 3 (21% affordable housing) | Residential & Mixed Use Tier 4 (25% affordable housing) | Residential & Mixed Use (100% affordable housing) | Group Living Accommodation | Non-Residential | |
| Lot Area Minimum | | | | | | | | 23.304.020 |
| New Lots | No minimum | | | | | | | |
| Per Group Living Accommodation Resident | N/A | | | | | 350 sq. ft. [1] | N/A | |
| Usable Open Space, Minimum [3] | 40 sq. ft. | | | | | | | |
| Per Dwelling Unit/GLA Resident [4] | N/A | | | | | 40 sq. ft. | | 23.304.090 |
| Floor Area Ratio, Maximum | 2.0 | 3.5 | 4.0 | 5.0 | 5.0 | 2.5 | 2.8 | |
| Residential Density, Maximum (du/acre) [2] | 100 | 150 | 210 | 250 | 250 | 1 GLA resident per 350 sf of lot area | N/A | |

| | | | | | | | | |
|--|---|----------------------|----------------------|----------------------|----------------------|----------------------|----------------------|------------------------------|
| Main Building Height, Maximum | 3 stories 35 feet | 5 stories 55 feet | 6 stories 65 feet | 7 stories 75 feet | 7 stories 80 feet | 4 stories 45 feet | 3 stories 45 feet | |
| Lot Line Setbacks, Minimum | | | | | | | | |
| Abutting/Confronting a Non-residential District | No minimum | | | | | | | 23.304.030 |
| Abutting/Confronting a Residential District | 10 ft 20 ft from any shared lot line for any portion exceeding 35 feet 45 ft from front property line for any portion exceeding 45 feet | | | | | N/A | | 23.304.030 23.204.150.E.4 |
| Building Separation, Minimum | No minimum | | | | | | | 23.304.040 |
| Interior Lot | 60% | 90% | 90% | 90% | 90% | 60% | 100% | |
| Corner Lot | 70% | 90% | 90% | 95% | 95% | 70% | 100% | |
| Lot Coverage, Maximum | 100% | | | | | | | |
| <p>Notes:</p> <p>[1] One additional resident is allowed for remaining lot area between 200 and 350 square feet.</p> <p>[2] For the purpose State Density Bonus calculation, the Tier 1 density is the maximum allowable gross residential density. Tier 2, 3, and 4 density is authorized as a local density bonus under Government Code section 65915(n).</p> <p>[3] An AUP may be granted to reduce useable open space requirements if shown to be necessary to build an all-electric building.</p> <p>[4] Each square-foot of open space that is designated as publicly accessible open space shall be counted as two square-feet of required on-site open space.</p> <p>[5] Affordable units calculated as percentage of total units</p> | | | | | | | | |

F. Design Standards.

1. **Adeline Corridor Specific Plan.** New buildings and additions shall be reviewed for conformance to the design guidelines in the Adeline Corridor Specific Plan.
2. **Ground Floor Frontages.**
 - a. **All New Buildings.** Except as set forth below, ground floor frontages of all new buildings are subject to the following design standards:
 - i.* Blank walls along the ground floor shall be less than 30 feet in length along sidewalks, pedestrian paths, or open space.
 - ii.* Ground floors shall have a minimum floor to floor height of 12 feet.
 - iii.* Facades shall provide at least 30 percent transparency between 3 and 10 feet above grade (doors and transparent windows) to allow maximum visual interaction between the sidewalk areas and building interiors. Dark or mirrored glass will not satisfy this requirement.
 - iv.* Window glazing shall provide a high degree of light transmittance and be non-reflective.
 - b. **Active Commercial Areas.** Ground floor frontages in areas identified as Active Commercial in Table 23.204-43 shall meet the requirements of 23.304.150.I.1 except:
 - i.* Ground floors shall have a minimum floor to floor height of 15 feet and a minimum floor to ceiling height of 12 feet.
 - ii.* Facades shall provide at least 75 percent transparency between 3 and 10 feet above grade (doors and transparent windows) to allow maximum visual interaction between sidewalk areas and the interior. Dark or mirrored glass will not satisfy this requirement.
 - c. **Commercial Use Areas.** Ground floor frontages in areas identified as commercial in Table 23.204-43 shall meet the requirements of 23.204.150.I.1 except:
 - i.* Ground floors shall have a minimum floor to floor height of 15 feet and a minimum floor to ceiling height of 12 feet.
 - ii.* Facades shall provide at least 65% transparency between 3 and 10 feet above grade (doors and transparent windows) to allow maximum visual interaction between sidewalk areas and the interior of office spaces. Dark or mirrored glass will not satisfy this requirement.
 - d. **Exceptions.** The Design Review Committee or Design Review staff may grant exceptions to the blank wall and transparency requirements.

G. Permit Findings.

1. **General.** To approve any AUP or Use Permit for a project in the C-AC district, the review authority must make the findings in Section 23.406.040– Master Use Permits and find that the proposed use or structure:
 - a. Is consistent with the purpose of the district;
 - b. Is compatible in design and character with the district and the adjacent residential neighborhoods;
 - c. Encourages utilization of public transit and off-street parking facilities in the area of the proposed building; and
 - d. Complies with the Adeline Corridor Specific Plan’s adopted Mitigation Monitoring and Reporting Program (MMRP).
2. **New Residential Development.** In addition to the findings above, the ZAB shall find, for each Use Permit for new residential development, that the proposed use or structure facilitates the construction of affordable housing as defined by the U.S. Department of Housing and Urban Development (HUD) Guidelines.
3. **Office Uses.**
 - a. To approve an AUP for an office use over 2,500 square feet or over 50 feet wide on the ground floor of an Active Commercial area, the Zoning Officer must find that the use supports the development of a strong retail commercial, pedestrian-oriented environment.
 - b. Factors the Zoning Officer should consider shall include, but are not limited to, pedestrian activity that is expected to be generated at the site, the placement of store entrances relative to the street and the parking lots, and the size and prominence of display windows and areas facing the sidewalk.
4. **All-Electric Buildings.** An AUP may be granted to reduce useable open space requirements if shown to be necessary to build an all-electric building. To approve an AUP, the Zoning Officer must find that:
 - a. No other placement of the features to support construction of an all-electric building, including solar photovoltaic (PV) energy systems and water tanks for heat pump water heating, on the property is possible; and
 - b. Placement of the features to support construction of an all-electric building elsewhere on the property is not financially feasible.

23.206 MANUFACTURING DISTRICTS

Sections:

- 23.206.010– Chapter Purpose
- 23.206.020– Allowed Land Uses and Permit Requirements
- 23.206.030– Additional Permit Requirements
- 23.206.040– Use-Specific Regulations
- 23.206.050– Protected Uses
- 23.206.060– M Manufacturing District
- 23.206.070– MM Mixed Manufacturing District
- 23.206.080– MU-LI Mixed Use-Light Industrial District
- 23.206.090– MU-R Mixed Use-Residential District
- 23.206.100– Permit Findings

23.206.010 – Chapter Purpose

This chapter identifies allowed land uses, permit requirements, and development standards for the Manufacturing Districts.

23.206.020 – Allowed Land Uses and Permit Requirements

- A. **Allowed Land Uses.** Table 23.206-1 identifies allowed land uses and required permits in the Manufacturing Districts. All land uses are defined in Chapter 23.502—Glossary. Permit requirements are described in Chapter 23.406—Specific Permit Requirements. Permits required for land uses shown in Table 23.206-1 apply to both:
1. The initial establishment of a land use in a new building; and
 2. The change of use in an existing building or portion of a building.

TABLE 23.206-1: ALLOWED LAND USES IN MANUFACTURING DISTRICTS

| ZC = Zoning Certificate AUP = Administrative Use Permit UP(PH) = Use Permit -- = Permitted with an AUP, see 23.206.020(B) NP = Not Permitted [#] = Floor Area Permit Requirement * Use-Specific Standards Apply | MANUFACTURING DISTRICTS | | | | Use-Specific Standards Applies to uses with an asterisk following the permit requirement (e.g., ZC*) |
|---|-------------------------|---------|---------|-------------------|--|
| | M | MM | MU-LI | MU-R | |
| Residential Uses | | | | | |
| Accessory Dwelling Unit | P | NP | NP | See 23.306 | |
| Dwellings | | | | | |
| Single-Family | NP | NP | NP | AUP* | 23.206.090.B.8 |
| Two Family | NP | NP | NP | AUP* | 23.206.090.B.8 |
| Multi-Family | NP | NP | NP | UP(PH)* | 23.206.090.B.7&8 |
| Group Living Accommodation | NP | NP | NP | UP(PH)* | 23.206.090.B.8 |
| Hotel, Residential | NP | NP | NP | NP | |
| Mixed-Use Residential | NP | NP | NP | UP(PH)* | 23.206.090.B.8&9 |
| Senior Congregate Housing | NP | NP | NP | See 23.302.040 .H | |
| Public and Quasi-Public Uses | | | | | |
| Child Care Center | NP | NP | AUP* | UP(PH)* | 23.206.040.B&C |
| Cemetery/Crematory/Mausoleum | NP | NP | NP | NP | |
| Club/Lodge | UP(PH)* | UP(PH)* | UP(PH)* | UP(PH) | 23.206.040.E |
| Columbaria | NP | NP | NP | – | |
| Community Care Facility | NP | NP | NP | ZC* | 23.206.090.B.3 |
| Community Center | NP | NP | NP | UP(PH) | |
| Emergency Shelter | NP | NP | NP | – | |

| ZC = Zoning Certificate AUP = Administrative Use Permit UP(PH) = Use Permit -- = Permitted with an AUP, see 23.206.020(B) NP = Not Permitted [#] = Floor Area Permit Requirement * Use-Specific Standards Apply | MANUFACTURING DISTRICTS | | | | Use-Specific Standards Applies to uses with an asterisk following the permit requirement (e.g., ZC*) |
|---|-------------------------|---------|-------------|----------|--|
| | M | MM | MU-LI | MU-R | |
| Family Day Care Home, Large | NP | NP | ZC* | AUP* | 23.206.040.C |
| Family Day Care Home, Small | NP | NP | ZC* | ZC* | 23.206.040.C |
| Hospital | NP | NP | NP | NP | |
| Library | NP | NP | NP | UP(PH) | |
| Mortuaries and Crematories | NP | NP | NP | UP(PH)* | 23.206.090.B.6 |
| Municipal Animal Shelter | UP(PH) | UP(PH) | UP(PH) | – | |
| Nursing Home | NP | NP | NP | UP(PH) | |
| Park/Playground | NP | NP | NP | UP(PH)* | 23.206.040.C |
| Public Safety and Emergency Service | UP(PH) | UP(PH) | UP(PH) | UP(PH) | |
| Public Utility Substation/Tank | UP(PH) | UP(PH) | UP(PH) | UP(PH) | |
| Religious Assembly | NP | NP | NP | UP(PH) | |
| School | NP | NP | NP | UP(PH)* | 23.206.040.C |
| School, Vocational | NP | NP | ZC* [1] | UP(PH) | 23.206.080.B.12 |
| Retail Uses | | | | | |
| Alcoholic Beverage Retail Sale | NP | NP | UP(PH)* [2] | NP * | 23.206.080.B.3; 23.206.090.B.2; 23.310 |
| Firearm/Munitions Business | NP | NP | NP | NP | |
| Industrial and Mining Products | AUP [2] | AUP [2] | AUP [4] | NP | |
| Pawn Shop/Auction House | NP | NP | NP | NP | |
| Pet Store | NP | NP – | NP | NP | |
| Retail, General | NP | NP | AUP* [5] | AUP* [3] | 23.206.080.B.6; |

| ZC = Zoning Certificate AUP = Administrative Use Permit UP(PH) = Use Permit -- = Permitted with an AUP, see 23.206.020(B) NP = Not Permitted [#] = Floor Area Permit Requirement * Use-Specific Standards Apply | MANUFACTURING DISTRICTS | | | | Use-Specific Standards Applies to uses with an asterisk following the permit requirement (e.g., ZC*) |
|---|-------------------------|---------|---------|---------|--|
| | M | MM | MU-LI | MU-R | |
| | | | | | 23.206.090.B.4 |
| Smoke Shop | NP | NP | NP | NP | |
| Personal and Household Service Uses | | | | | |
| Personal and Household Services, General | NP | NP | NP | AUP | |
| Kennels and Pet Boarding | NP | NP | NP | UP(PH) | |
| Laundromats and Cleaners | NP | NP | NP | AUP | |
| Veterinary Clinic | NP | NP | NP | UP(PH) | |
| Video Tape/Disk Rental | NP | NP | NP | NP | |
| Office Uses | | | | | |
| Business Support Services | NP | NP | AUP [6] | AUP [3] | |
| Banks and Financial Services, Retail | NP | NP | – | NP | |
| Insurance Agents, Title Companies, Real Estate Agents, Travel Agents | NP | NP | – | – | |
| Medical Practitioners | NP | NP | NP | AUP [3] | |
| Non-Chartered Financial Institutions | NP | NP | – | – | |
| Office, Business and Professional | NP | ZC* [4] | AUP [4] | AUP [3] | 23.206.070.B.2 |
| Food and Alcohol Service, Lodging, Entertainment, and Assembly Uses | | | | | |
| Adult-oriented Business | - | - | NP | NP | |
| Amusement Device Arcade | NP | NP | – | NP | |

| ZC = Zoning Certificate AUP = Administrative Use Permit UP(PH) = Use Permit -- = Permitted with an AUP, see 23.206.020(B) NP = Not Permitted [#] = Floor Area Permit Requirement * Use-Specific Standards Apply | MANUFACTURING DISTRICTS | | | | Use-Specific Standards Applies to uses with an asterisk following the permit requirement (e.g., ZC*) |
|---|-------------------------|---------|---------|--------|--|
| | M | MM | MU-LI | MU-R | |
| Bar/Cocktail Lounge/Tavern | NP | NP | – | – | |
| Commercial Recreation Center | NP | NP | – | NP | |
| Dance/Exercise/Martial Arts/Music Studio | NP | NP | – | UP(PH) | |
| Entertainment Establishment | NP | NP | – | UP(PH) | |
| Food Service Establishment | See 23.302.040.E | | | | |
| Group Class Instruction | NP | NP | – | UP(PH) | |
| Gym/Health Club | NP | NP | – | NP | |
| Hotel, Tourist | NP | NP | NP | NP | |
| Motel, Tourist | NP | NP | NP | NP | |
| Theater | NP | NP | UP(PH)* | NP | 23.206.080.B.10 |
| Vehicle Service and Sale Uses | | | | | |
| Alternative Fuel Station | AUP [4] | AUP [4] | AUP [4] | AUP | |
| Gasoline/Vehicle Fuel Station | NP | NP | NP | NP | |
| Large Vehicle Sales and Rental | – | NP | AUP [4] | NP | |
| Small Vehicle Sales and Rental | – | NP | NP | NP | |
| Tire Sales and Service | – | – | – | NP | |
| Vehicle Parts Store | NP | NP | NP | UP(PH) | |
| Vehicle Repair and Service | UP(PH) | UP(PH) | UP(PH) | UP(PH) | |
| Vehicle Rentals | NP | – | – | NP | |
| Vehicle Sales, New | AUP* [7] | NP | NP | NP | 23.206.060.B.3 |
| Vehicle Sales, Used | AUP* [7] | NP | NP | NP | 23.206.060.B.3 |

| ZC = Zoning Certificate AUP = Administrative Use Permit UP(PH) = Use Permit -- = Permitted with an AUP, see 23.206.020(B) NP = Not Permitted [#] = Floor Area Permit Requirement * Use-Specific Standards Apply | MANUFACTURING DISTRICTS | | | | Use-Specific Standards Applies to uses with an asterisk following the permit requirement (e.g., ZC*) |
|---|-------------------------|---------|----------|----------|--|
| | M | MM | MU-LI | MU-R | |
| Vehicle Wash | NP | NP | NP | NP | |
| Vehicle Wrecking | AUP [7] | AUP [4] | AUP* [4] | NP | 23.206.080.B.11 |
| Industrial and Heavy Commercial Uses | | | | | |
| Bus/Cab/Truck/Public Utility Depot | AUP [8] | AUP [8] | AUP* [4] | UP(PH) | 23.206.080.B.4 |
| Commercial Excavation | UP(PH) | UP(PH) | UP(PH) | NP | |
| Contractors Yard | AUP [7] | AUP [7] | AUP [4] | UP(PH) | |
| Dry Cleaning and Laundry Plant | ZC* [9] | ZC [9] | ZC [1] | UP(PH) | 23.206.060.B.2 |
| Laboratory | | | | | |
| Commercial Physical or Biological | NP | AUP [4] | UP(PH)* | NP | 23.206.080.B.5 |
| Cannabis Testing | NP | AUP [4] | UP(PH) | NP | |
| Manufacturing | | | | | |
| Construction Products | ZC* [9] | ZC* [9] | UP(PH)* | NP | |
| Light Manufacturing | ZC* [7] | ZC* [7] | ZC* [1] | AUP* [3] | 23.206.090.B.5 |
| Pesticides/Herbicides/Fertilizers | NP | NP | NP | - | |
| Petroleum Refining and Products | NP | NP | NP | - | |
| Pharmaceuticals | AUP [4] | AUP [4] | AUP* [4] | - | 23.206.080.B.7 |
| Primary Production Manufacturing | AUP [4] | AUP [4] | NP | NP | |
| Semiconductors | UP(PH) | UP(PH) | NP | - | |
| Material Recovery Enterprise | - | - | UP(PH) | - | |
| Media Production | ZC [10] | ZC [10] | ZC [10] | AUP [11] | |
| Mini-storage | NP | NP | NP | NP | |

| ZC = Zoning Certificate AUP = Administrative Use Permit UP(PH) = Use Permit -- = Permitted with an AUP, see 23.206.020(B) NP = Not Permitted [#] = Floor Area Permit Requirement * Use-Specific Standards Apply | MANUFACTURING DISTRICTS | | | | Use-Specific Standards Applies to uses with an asterisk following the permit requirement (e.g., ZC*) |
|---|-------------------------|-----------|------------------|-------------------|--|
| | M | MM | MU-LI | MU-R | |
| Recycled Materials Processing | ZC* [9] | ZC* [9] | UP(PH)* | – | 23.206.040.H; 23.206.080.B.9 |
| Recycling Redemption Center | AUP [7] | ZC [9] | UP(PH)* | AUP | 23.206.080.B.9 |
| Repair Service, Non-Vehicle | ZC* [9] | ZC* [9] | ZC* [1] | AUP | 23.206.040.G |
| Research and Development | - | ZC [12] | ZC [12] | – | |
| Services to Buildings and Dwellings | AUP | AUP | AUP | AUP | |
| Warehouse | ZC [9] | ZC [9] | ZC [1] | UP(PH) | |
| Warehouse-Based Non-Store Retailer | ZC [9] | ZC [9] | ZC [1] | – | |
| Wholesale Trade | ZC [9] | ZC [9] | ZC* [1] | AUP [3] | 23.206.080.B.13 |
| Incidental Uses | | | | | |
| Amusement Devices | NP | NP | AUP | AUP | |
| Alcoholic Beverage Service | See 23.310 | | | | |
| Cafeteria, On-Site | ZC [2] | AUP [2] | ZC [2] | AUP | |
| Child Care Center | NP | NP | See 23.206.040.B | | |
| Columbaria | – | – | – | – | |
| Food and Beverage for Immediate Consumption | – | AUP [2] | – | – | |
| Food Service Establishment | AUP [2] | - | AUP [2] | AUP | |
| Home Occupations | NP | NP | NP | See 23.206.040 | |
| Live Entertainment | NP | NP | UP(PH)* | UP(PH)* | 23.302.020.D |
| Retail Sales of Goods Manufactured On-Site | AUP* [13] | AUP* [14] | AUP* [14] | AUP* | 23.206.040.I |

| ZC = Zoning Certificate AUP = Administrative Use Permit UP(PH) = Use Permit -- = Permitted with an AUP, see 23.206.020(B) NP = Not Permitted [#] = Floor Area Permit Requirement * Use-Specific Standards Apply | MANUFACTURING DISTRICTS | | | | Use-Specific Standards Applies to uses with an asterisk following the permit requirement (e.g., ZC*) |
|---|-------------------------|---------|--------------|----------|--|
| | M | MM | MU-LI | MU-R | |
| Storage of Goods Manufactured On-Site (>25% gross floor area) | ZC | ZC | ZC | AUP | |
| Wholesale Activities | ZC | ZC | ZC | AUP | |
| Other Miscellaneous Uses | | | | | |
| Art/Craft Studio | ZC* [10] | ZC [10] | ZC* [10] | AUP [11] | 23.206.040.A |
| ATM, Exterior and Attached to Bank | AUP | AUP | - | AUP | |
| ATM, Interior or Exterior and Not With Bank | AUP | AUP | AUP | AUP | |
| Circus/Carnival | NP | NP | UP(PH)* | UP(PH) | 23.206.040.D |
| Drive-in Uses | NP | NP | NP | NP | |
| Live/Work | NP | NP | See 23.312 | | |
| Parking Lot/Structure | See 23.302.070.G | | | | |
| Public Market, Open Air | - | - | UP(PH)* [15] | - | 23.206.080.B.8 |
| Public Market, Enclosed | - | - | AUP [5] | - | |
| Short-Term Rental | - | - | - | ZC* | 23.314 |
| Urban Agriculture, Low-Impact | ZC | ZC | ZC | ZC | |
| Urban Agriculture, High-Impact | AUP | AUP | AUP | AUP | |
| Notes: | | | | | |
| [1] Requires an AUP for uses 20,000 sq. ft. to 30,000 square feet. Requires a Use Permit for uses more than 30,000 sq. ft. | | | | | |
| [2] Not permitted 20,000 sq. ft. or more. | | | | | |
| [3] Requires a Use Permit if 5,000 sq. ft. or more | | | | | |
| [4] Requires a Use Permit for uses more than 20,000 sq. ft. | | | | | |
| [5] Not permitted over 2,000 sq. ft. | | | | | |

| ZC = Zoning Certificate AUP = Administrative Use Permit UP(PH) = Use Permit -- = Permitted with an AUP, see 23.206.020(B) NP = Not Permitted [#] = Floor Area Permit Requirement * Use-Specific Standards Apply | MANUFACTURING DISTRICTS | | | | Use-Specific Standards Applies to uses with an asterisk following the permit requirement (e.g., ZC*) |
|--|-------------------------|----|-------|------|--|
| | M | MM | MU-LI | MU-R | |
| [6] Not permitted over 3,000 sq. ft. [7] Requires a Use Permit for uses more than 40,000 sq. ft. [8] Requires a Use Permit for uses 20,000 sq. ft. to 40,000 square feet. [9] Requires an AUP for uses 20,000 sq. ft. to 40,000 square feet. Requires a Use Permit for uses more than 40,000 sq. ft. [10] Requires an AUP for uses 10,000 sq. ft. to 20,000 square feet. Requires a Use Permit for uses more than 20,000 sq. ft. [11] Allowed with Zoning Certificate if under 1,000 sq. ft.. Requires Use Permit if over 20,000 sq. ft. [12] Requires an AUP for uses more than 20,000 sq. ft. [13] Not permitted 1,500 sq. ft. or more. [14] Requires a Use Permit for sales area 1,501 to 3,000 sq. ft. Not permitted over 3,000 sq. ft. [15] Requires Use Permit for markets over 5,000 sq. ft. | | | | | |

- B. **Unlisted Land Uses.** Any use not listed in Table 23.206-1 is permitted with an AUP. To approve the AUP, the Zoning Officer must find that the use is compatible with the purposes of the district where it is located. Any use found to be incompatible with the purposes of the district is not permitted.
- C. **Use-Specific Regulations.** Uses subject to supplemental regulations are shown in in Table 23.206-1 with an asterisk (*) following the permit requirement (e.g., ZC*). The Use-Specific Standards column in Table 23.206-1 identifies the location of these standards in the Zoning Ordinance.

23.206.030 – Additional Permit Requirements

- A. **New Floor Area.** A project that creates new floor area for any use requires additional permits as shown in Table 23.206-1. Creation of new floor area includes:
 1. Construction of new main buildings or accessory buildings;
 2. Additions to existing buildings; or
 3. The installation of new floor or mezzanine levels within or onto existing buildings.

TABLE 23.206-2: NEW FLOOR AREA PERMIT REQUIREMENTS

| District/New Gross Floor Area | Permit Required for New Floor Area |
|------------------------------------|------------------------------------|
| M, MM | |
| Less than 20,000 sq. ft. | ZC |
| 20,000 to less than 40,000 sq. ft. | AUP |
| 40,000 sq. ft. or more | UP(PH) |
| MU-LI | |
| Less than 10,000 sq. ft. | ZC |
| 10,000 to less than 20,000 sq. ft. | AUP |
| 20,000 sq. ft. or more | UP(PH) |
| MU-R | |
| Less than 5,000 sq. ft. | ZC |
| 5,000 to less than 10,000 sq. ft. | AUP |
| 10,000 sq. ft. or more | UP(PH) |

B. Tenant Space Reconfiguration.

1. Reconfiguration of tenant space in an existing building in the M, MM, and MU-LI districts requires a permit as listed in Table 23.206-3.

2. In the MU-R district, tenant space reconfiguration projects affecting 5,000 square or more require a Use Permit.
3. As used in this section, tenant reconfiguration means any physical change to an existing building's walls separating leased spaces so as to change:
 - a. The number of lease spaces for commercial businesses; or
 - b. The square footage of leasable floor area of an existing commercial lease space.

TABLE 23.206-3: TENANT SPACE RECONFIGURATION REQUIREMENTS IN THE M, MM, AND MU-LI DISTRICTS

| Tenant Space Reconfiguration Project | Permit Required for Tenant Space Reconfiguration Project |
|--|--|
| Previously separated spaces combined into a larger space | ZC |
| Creating 2 to 5 separate new tenant spaces | ZC |
| Creating 6 to 9 separate new tenant spaces | AUP |
| Creating 10 or more separate new tenant spaces | UP(PH) |

4. **MM District Findings.** To approve an AUP or Use Permit for a tenant reconfiguration project in the MM district, the review authority must find that the conversion is necessary to implement the purpose of the district.
5. **MU-LI District Findings.** To approve a Use Permit for a tenant reconfiguration project in the MU-LI district, the review authority must find that the reconfiguration would not create or contribute to a shortage of industrial spaces in West Berkeley for spaces of the size being converted and either:
 - a. The reconfiguration can be reasonably expected to better serve the purposes of the district than leaving the space intact; or
 - b. The reconfiguration would create spaces which could cross-subsidize larger industrial spaces.

C. Major Residential Additions.

1. **Where Allowed/Required Permits.**
 - a. Major residential additions in the MU-R district require an AUP.
 - b. Major residential additions are not permitted in MU-LI district.

- c. Major residential additions in the M and MM districts are subject to the requirement in Section 23.324 (Nonconforming Uses, Structures, and Buildings).
 - 2. **Findings.** To deny an AUP for a major residential addition in the MU-R district, the review authority must find that:
 - a. The proposed addition would unreasonably interfere with existing or reasonably foreseeable adjacent land uses in the M or MM district; or
 - b. Existing or reasonably foreseeable adjacent land uses in the M and/or MM district would have a material adverse effect on the use of the proposed addition.
 - 3. **Recorded Acknowledgement.** For a residential addition in the MU-R district, the residential property owner shall record an acknowledgement on the title that existing or reasonably foreseeable adjacent land uses in the M and/or MM District may create noise, dust, odors, light/glare, and other impacts that shall not be considered a nuisance if they are developed and conducted pursuant to the standards of the district.
- D. **Langendorf Building.** The following applies to the property occupied by the Langendorf Building (2929 Seventh Street, APN 053-0164300102):
- 1. Commercial physical and biological laboratories are allowed with a Use Permit if at least 6,000 square feet of gross floor area is occupied by a permitted use.
 - 2. Retail, office, and food and alcohol service uses allowed in the C-W district are allowed in the MU-LI portion of the property if the total gross floor area of these uses are less than 10,000 square feet.
- E. **Changes to Nonconforming Structures.** See Section 23.324.050 (Nonconforming Structures and Buildings) for permits required to modify structures that do not conform to setback, height, and other development standards.
- F. **Accessory Structures.** For accessory structure permit requirements, see the following:
- 1. Section 23.304.060 (Accessory Buildings and Enclosed Accessory Structures).
 - 2. Section 23.304.070 (Unenclosed Accessory Structures in Residential Districts).
 - 3. Section 23.304.080 (Fences).

23.206.040 – Use-Specific Regulations

- A. **Art/Craft Studios in the M and MU-LI Districts.** Art/craft studios are allowed in the M and MU-LI districts only as workspaces. Live/work is not permitted.

B. Child Care Centers in the MU-LI and MU-R Districts. Table 23.206-4 shows permit requirements for child care centers in the MU-LI and MU-R districts.

TABLE 23.206-4: MU-LI AND MU-R CHILD-CARE CENTER PERMIT REQUIREMENTS

| Use Characteristic | Permit Required |
|--|-----------------|
| Incidental Use | |
| Providing childcare for employees only | ZC |
| Providing childcare for non-employees | AUP |
| Principal Use | UP(PH) |

C. Child-Serving Uses in the MU-LI and MU-R Districts.

1. As used in this section, “child-serving use” means a school, child care center, family day care, or park/recreational facility used by children.
2. Before acting on an application to establish or expand a child-serving use in the MU-LI or MU-R districts, the applicant shall prepare and submit to the City an appropriate risk analysis or risk assessment, as determined by the City, that evaluates the risk to children in the use from other activities near the site.
3. All child-serving uses in the MU-LI and MU-R districts must notify in writing, on a form approved by the City, all parents of children in the child-serving use that the use is in the MU-LI or MU-R district, light manufacturing is a permitted activity in the district, and that primary production manufacturing or construction products manufacturing may be permitted uses in adjacent districts. The child-serving use must require each parent or guardian to confirm in writing that they have read and understood this information. Written confirmations shall be returned to the child-serving use and maintained at the use for City review.
4. To approve an AUP or Use Permit to establish or expand a child-serving use, the review authority must find that:
 - a. The child-serving use is not incompatible with adjacent and nearby uses, including industrial uses;
 - b. The risk analysis or risk assessment shows that there is not significant risk to children in the use from other activities near the site; and
 - c. The applicant has made adequate provisions to comply with the parent/guardian notification requirement in Paragraph (3) above.

D. Circuses and Carnival in the MM and MU-LI Districts. Circuses and carnivals are allowed in the MM and MU-LI districts only as a temporary use.

- E. **Club and Lodges in the M, M-M, and MU-LI Districts.** Clubs and lodges are allowed in the M, M-M, and MU-LI districts only for persons working in the district.
- F. **Manufacturing Uses in the M, MM, and MU-LI Districts.** For manufacturing uses in the M, MM, and MU-LI districts otherwise allowed with a Zoning Certificate, an AUP is required to establish the use within 150 feet of a residential use in a Residential District or in the MU-R district.
- G. **Non-Vehicle Repair Service in the M, MM, and MU-LI Districts.** Retail sales associated with a non-vehicle repair service are not permitted in the M, MM, and MU-LI districts.
- H. **Recycled Materials Processing in the M and MM Districts.** For recycled materials processing facilities under 10,000 square feet in the M and MM districts, an AUP is required if processing occurs outside of a building.
- I. **Retail Sale of Goods Manufactured On-Site.** The following requirements apply to incidental retail sales in all Manufacturing Districts:
 1. The size and character of signs for the retail use shall clearly indicate that the retail use is not the primary use of the site
 2. Maximum retail floor area: 10 percent of total gross floor area.
 3. Outdoor sales or food service is not permitted.
- J. **Storage, Wholesale, Manufacturing as Incidental Use.** If a storage, wholesale, or manufacturing use is allowed in the M, MM, and MU-R district with a Zoning Certificate, the use is allowed incidental to another permitted use without the need to obtain an AUP or Use Permit.
- K. **Noise.** For purposes of the Noise Ordinance, Municipal Code Chapter 13.40, the Manufacturing Districts are considered Industry Districts.

23.206.050 – Protected Uses

- A. **Protected Industrial Uses in the MM and MU-LI Districts.** The industrial use protections in this subsection apply in the MM and MU-LI districts.
 1. **Uses Subject to Protection.** Table 23.206-5 identifies protected industrial uses in the MM and MU-LI districts and when the requirements in this subsection apply to these uses. Protections apply only to legally-established uses.

TABLE 23.206-5: PROTECTED INDUSTRIAL USES

| Zoning District | Protected Industrial Uses | Applicability of Requirements |
|-----------------|---|---|
| MM | Manufacturing, warehousing, wholesale trade | Ground-level protected uses on or after January 1, 1988 [1] |

| | | |
|---|---|--|
| MU-LI | Material recovery enterprise, manufacturing, warehousing, wholesale trade | Buildings with 33% protected use on or after January 1, 1996 [1] |
| <p><u>Note:</u> [1] Includes protected uses that were previously used on or after this date but now vacant.</p> | | |

- a. In the MM district, requirements in this subsection apply if protected use space is used, or has been used, for the manufacture, assembly, processing, repair, testing (including prototype manufacturing), storage, display (other than in retail stores) or distribution of goods. Requirements do not apply in the MM district if the protected use is or was demonstrably ancillary to another use.
- 2. **Permits Required.** Table 23.206-6 identifies permits required if a protected industrial use is changed to any use that is not a protected industrial use.

TABLE 23.206-6: PERMITS REQUIRED FOR CHANGES TO PROTECTED LAND USES

| Zoning District | Change to Protected Use | Permit Required |
|-----------------|---|-----------------|
| MM | Change any amount of ground-floor protected use to a non-protected use | UP(PH) |
| MU-LI | Change 20,000 sq. ft. or less and 25% of protected use to a non-protected use | AUP |
| | Change over 20,000 sq. ft. or 25% of protected use to a non-protected use | UP(PH) |

- 3. **Permit Findings.**
 - a. To approve a permit required by Table 23.206-6 for changes to a protected industrial use in the MM and MU-LI districts, the review authority must find that replacement space is provided as required by Paragraph 4 (Replacement Space) below.
 - b. To approve a Use Permit for a change of 25 percent more to a protected use in the MU-LI district, the Zoning Adjustments Board (ZAB) must also find that either:
 - i. The City has approved necessary Use Permits to provide comparable quality replacement space in Berkeley at a comparable rent that will be available before the demolition or change of use of the space; or
 - ii. Both of the following:

1. As a result of lawful business and building activities, there are exceptional physical circumstances (exclusive of the presence of hazardous materials in the building(s), soil or groundwater) found at the building not generally found in industrial buildings in the MU-LI district which make it financially infeasible to reuse the building for any of protected industrial uses permitted in the district. The analysis of the financial feasibility effects (which shall be verified by the City) of these physical circumstances shall consider those costs necessary to make the building meet current minimum standards for manufacturing, wholesale trade or warehouse buildings.
2. Appropriate mitigation has been made for loss of the protected industrial use space in excess of 25 percent of that space through providing such space elsewhere in the City, payment into the West Berkeley Building Acquisition Fund, or by other appropriate means.
4. **Replacement Space.** Floor area occupied by a protected industrial use that is changed to a non-protected use must be replaced, in the West Berkeley Plan area, by a comparable space devoted to one or more of protected industrial uses.
5. **Minimum Protected Use Floor Area – MM District.** For properties in the MM district where 25 percent or more of the total gross floor area was occupied by a protected industrial use as of January 1, 1996, protected industrial uses may not be reduced to less than 25 percent of the total gross floor area on the property.
6. **Cumulative Limitations – MU-LI District.** Permit requirements for changes to protected industrial uses in the MU-LI district are cumulative.
7. **Exceptions.** Changes to protected industrial uses in the MM and MU-LI districts described below are exempt from the requirements in Paragraphs 2-6 above.
 - a. **Changes to R&D Uses.**

A protected warehouse or wholesale trade use established before January 1, 2010 may be changed to a research and development (R&D) use with the permits shown in Table 23.206-7.

TABLE 23.206-7: PERMITS FOR CHANGES FROM PROTECTED TO R&D USES

| Change in Protected Use Gross Floor Area | Permit Required |
|---|-----------------|
| 20,000 square feet or less | AUP |
| Over 20,000 square feet | UP(PH) |

- i.* A maximum of 150,000 square feet of protected warehouse or wholesale trade space occupied on or after August 1, 2011 may be converted to R&D. This maximum applies regardless of whether or not the protected warehouse or wholesale trade space was legally established.
- b. Changes to Warehouse-Based Non-Store Retail, Art/Craft Studio, and Contractor Uses.** A protected industrial use may be changed to a warehouse-based non-store retail, art/craft studio, or contractor use with the permit required by Section 23.206.020 (Allowed Land Uses and Permit Requirements).
- c. Langendorf Building.** Protected industrial uses in the Langendorf Building (2929 Seventh Street) may be changed to a non-protected use if at least 30,000 square feet of total gross floor area remains as a protected industrial use.
- d. MU-LI Lots with Multiple Owners.** Protected industrial uses in the MU-LI district may be changed to a non-protected use if:
 - i.* The protected industrial use is on a lot or group of abutting and confronting lots under single ownership and with more than one building; and
 - ii.* 25 percent or less of the total gross floor area in all buildings on the lot(s) remains as a protected industrial use.
- e. Prior Protections Remain.** Establishing a new non-protected use under 23.206.050.A.7 (Exceptions) does not eliminate any protections for the prior protected use and such protections will remain if the new non-protected use ceases.

8. Reports to City Council.

- a.** The Planning and Development Department will report to the City Council once a cumulative total of 50,000 square feet in the MM and MU-LI districts of protected warehousing or wholesale trade use is converted to a R&D use (or at the end of one year, whichever occurs first). The Department will provide additional reports in the same increments after this first report. The reports will include the gross square footage of building space converted and the number and type of jobs expected to be created.
- b.** No later than April 15, 2016, the City Manager will provide a cumulative report to the City Council and schedule an action item for the Council's consideration so that it can provide direction as to what, if any, modifications it wishes to make to this section.

B. Protected Industrial Uses in the MU-R District.

1. **Protected Industrial Uses Defined.** Manufacturing, warehousing, and wholesale trade are protected industrial uses in the MU-R district. Protections apply only to legally-established uses.
2. **Permit Required.** Except as allowed by Section 23.206.050.B.4 (Exempt from Permit Requirement), a Use Permit is required to change a protected industrial use to any use that is not a protected industrial use.
3. **Permit Findings.** To approve a Use Permit when required by Section 23.206.050.B.2 (Permit Required), the review authority must find that:
 - a. The change of use will not have a materially detrimental impact on the character of the MU-R district as a light industrial district, with particular reference to the character of the blocks and parts of blocks in the part of the district that is contiguous with the site; and
 - b. Appropriate mitigation has been made for loss of the manufacturing, wholesale trade, or warehouse space in excess of 25 percent of that space through providing such space elsewhere in Berkeley, payment into the West Berkeley Building Acquisition Fund, or by other appropriate means.
4. **Exempt from Permit Requirement.** A protected industrial use may be changed to an art/craft studio or contractor use with the permit required by Section 23.206.020 (Allowed Land Uses and Permit Requirements). Approval of an art/craft studio or contractor use within a protected industrial space does not eliminate any protections for the prior protected use and such protections will remain if the new non-protected use ceases.

C. Protected Non-Industrial Uses in the MU-LI and MU-R Districts.

1. **Protected Non-Industrial Uses Defined.** A use in the MU-LI or MU-R districts listed in Table 23.206-8 is classified as a protected non-industrial use, provided the use:
 - a. Was legally established as of July 6, 1989; and
 - b. Exists as a single stand-alone use or is combined with residential use in a live/work unit.

TABLE 23.206-8: PROTECTED NON-INDUSTRIAL USES

| Category | Protected Uses |
|-------------------|--|
| Category 1 | Art/craft studio |
| Category 2 | 1) Art galleries, ancillary to art/craft studios and when located in the same building 2) Child care facility 3) Family day care home 4) Fine arts performance, instruction and rehearsal studios |

| | |
|--|--|
| | (dance, music, theater) 5) Theaters, stage performance, but excluding motion picture theaters |
|--|--|

2. Permit Required for Change of Use.

- a. Table 23.206-9 shows permits required to change a protected non-industrial use.

TABLE 23.206-9: PERMITS REQUIRED FOR CHANGE TO PROTECTED NON-INDUSTRIAL USE

| Existing Protected Use Gross Floor Area | New Use | | |
|---|--------------------------------------|---|---|
| | A protected use in the same category | A protected use in a different category | A non-protected use that occupies all of the non-residential floor area in the building |
| Less than 5,000 sq. ft. | ZC | AUP | AUP |
| 5,000 sq. ft. or more | AUP | UP(PH) | UP(PH) |

- 3. **Owner-Occupied Exemption.** A protected non-industrial use which is owner-occupied and occupies all of the non-residential floor area in a building is exempt from the requirements of this section.

4. Findings.

- a. To approve a permit required by Table 23.206-9, the review authority must find that space occupied by the existing non-industrial protected use will be replaced with a comparable space in the West Berkeley Plan area, which is reserved for use by any protected use in the same category. Such replacement space may not qualify for exemption under Paragraph 3 (Owner-Occupied Exemption) above or by reason of having been established after July 6, 1989.
- b. When making additional findings required by Chapter 23.406 (Specific Permit and Approval Requirements), the review authority may only consider the potential detriment associated with the new use. Dislocation of any specific previous occupant or use may not be a basis for finding detriment.

23.206.060 – M Manufacturing District

A. District Purpose. The purpose of the Manufacturing (M) district is to:

- 1. Implement the West Berkeley Plan Manufacturing District designation;

2. Encourage development of a general manufacturing district for the full range of manufacturers, including larger scale materials processing manufacturers sometimes known as heavy manufacturers;
3. Consistent with other goals expressed in these purposes, encourage development of a manufacturing district dedicated to manufacturing and industrial uses, so that manufacturers and industrial businesses will not be interfered with by incompatible uses;
4. Encourage the creation and continuation of well-paid (often unionized) industrial jobs for people without advanced degrees;
5. To the greatest degree possible and consistent with other goals expressed in these purposes, retain the stock of manufacturing and industrial buildings and/or sites, especially large buildings and sites, for manufacturing and industrial uses;
6. Support the development of industrial businesses which contribute to the maintenance and improvement of the environment;
7. Maintain and improve the quality of the West Berkeley environment, while allowing the lawful and reasonable operation of the full range of manufacturers;
8. Support the development of retail automobile sales uses because they contribute to the economic viability of the area and provide sales tax revenues for the City; and
9. Provide opportunities for vehicle sales uses when it will not unduly interfere with manufacturing uses.

B. Land Use Regulations.

1. **Allowed Land Uses.** See Table 23.206-1: Allowed Land Uses in Manufacturing Districts.
2. **Dry Cleaning and Laundry Plants.** Retail service at a dry cleaning and laundry plant in the M district is not permitted.
3. **Vehicle Sales.** The following standards apply to both new and used vehicle sales in the M district.
 - a. Permits required for vehicle sales in the M district is determined by size of lot, not floor area.
 - b. Vehicle sales are not permitted on City-owned land used for a materials recovery enterprise or solid waste transfer station as of January 1, 2008.
 - c. When a project results in construction of a new building with more than 10,000 square feet of new gross floor area, the following standards apply to the new building:

- i.* A minimum building frontage of 40 percent of the project's primary street frontage is required within 25 feet of the public right-of-way. The primary street frontage is the frontage towards which the primary building entrance is oriented.
 - ii.* Along Gilman Street a minimum building frontage of 50 percent of the Gilman Street frontage is required within 25 feet of the public right-of-way.
 - iii.* The minimum building height is 20 feet within 25 feet of the public right-of-way along the primary street frontage.
- d. Adequate landscaping and/or fencing shall be used to screen views from street level of dealership operations that are not located within a building. Outdoor vehicle storage and display does not need screening. Such screening is not required to obscure all visibility of interior activities but shall provide some filtering of outdoor dealership operations.
- e. For the purposes of this section and Design Review, areas used for outdoor vehicle storage and display are not considered parking areas.
- f. Appropriate site design measures shall be installed to the maximum extent practicable to ensure clean water standards are met. Permanent stormwater best management practices and on-site storm water treatment shall be used for all runoff generated by new impermeable surfaces. Runoff from automobile washing and maintenance activities shall be properly collected and treated, consistent with the requirements of the Public Works Department and the Toxics Management Division of the Planning Department. When new paving is proposed, pervious paving shall be used where feasible and shall be reviewed and approved by the Public Works Department and Office of Transportation.
- g. All noise-generating activities and equipment, such as vehicle repair, shall be shielded by noise-attenuating construction or equipment. Outdoor amplification is not permitted.
- h. Exterior light standards and fixtures shall not be taller than 20 feet, light cutoffs shall be used to control light spillover onto adjacent properties, and low energy light fixtures consistent with Berkeley's goals for energy efficiency shall be used.
- i. Vehicle test drives shall not be conducted in adjacent Residential Districts.
- j. Facilities for the loading and unloading of deliveries shall be provided on-site and may not occupy street parking or block public or private streets. On-street unloading is permitted with an AUP. To approve the AUP, the Zoning Officer must find that:

- i.* On-street loading will not be unreasonably disruptive or detrimental to activities in the vicinity; and
 - ii.* On-site deliveries are not feasible due to specific site or roadway constraints.
- k. To approve an AUP or Use Permit for an automobile sales use in the M district, the review authority must find that:
 - i.* The project will not result in unreasonable impacts on circulation and parking on adjacent streets or in the immediate neighborhood;
 - ii.* The project will not result in a substantial adverse impact on existing uses in the immediate vicinity;
 - iii.* The project will not generate objectionable odors or excessive levels of noise;
 - iv.* Site design reflects the urban form of the surrounding area and new construction, materials and/or building forms reflect the area’s industrial character;
 - v.* New construction along Gilman Street reflects the importance of a defined street wall along this main entry corridor to the city; and
 - vi.* The project will not materially interfere with the activities of the City-owned solid waste center.

C. **Additional Permit Requirements.** See Section 23.206.030 (Additional Permit Requirements).

D. **Development Standards.** See Table 23.206-10 for development standards in the M district.

TABLE 23.206-10: M DEVELOPMENT STANDARDS

| BASIC STANDARDS | | SUPPLEMENTAL STANDARDS |
|--|----------------|-------------------------------|
| Lot Area, Minimum | 20,000 sq. ft. | 23.304.020– Lot Requirements |
| Usable Open Space Per Dwelling Unit, Minimum | n/a | |
| Floor Area Ratio, Maximum | 2.0 | |
| Main Building Height, Maximum | 45 ft. | 23.304.050– Building Height |
| Lot Line Setbacks, Minimum | | 23.304.030– Setbacks |

| | | |
|------------------------------|------------|--|
| Front | No minimum | |
| Rear | No minimum | |
| Interior Side | No minimum | |
| Street Side | No minimum | |
| Building Separation, Minimum | No minimum | |
| Lot Coverage, Maximum | 100% | |

E. **Permit Findings.** See – Permit Findings (Permit Findings).

23.206.070 – MM Mixed Manufacturing District

A. **District Purpose.** The purpose of the Mixed Manufacturing (MM) district is to:

1. Implement the West Berkeley Plan MM designation;
2. Encourage development of a general manufacturing district for the full range of manufacturers, including larger scale materials processing manufacturers sometimes known as heavy manufacturers;
3. Encourage development of a manufacturing district targeted to manufacturing and industrial uses, so that manufacturers and industrial businesses will not be interfered with by incompatible uses;
4. Encourage the creation and continuation of well paid (often unionized) jobs for men and women without advanced degrees;
5. Provide an appropriate location for the development of compatible industries which can provide high quality employment for people at all educational levels, and add significantly to the tax base, such as the biotechnology industry;
6. Allow reuse of upper story industrial space as offices to facilitate use of upper story space;
7. Maintain and improve the quality of the West Berkeley environment, while allowing the lawful and reasonable operation of the full range of manufacturers; and
8. Support the development of industrial businesses which contribute to the maintenance and improvement of the environment.

B. **Land Use Regulations.**

1. **Allowed Land Uses.** See Table 23.206-1: Allowed Land Uses in Manufacturing Districts.
2. **Office Uses.**

- a. Office uses are allowed in the MM district only above the ground floor. Ground floor office uses are not permitted unless ancillary to a permitted use.
- b. If the office use is established above a non-manufacturing use or replaces an existing manufacturing, warehousing or wholesale trade use, an AUP is required.

C. **Additional Permit Requirements.** See Section 23.206.030– Additional Permit Requirements.

D. **Development Standards.** See Table 23.206-11 for development standards in the MM district.

TABLE 23.206-11: MM DEVELOPMENT STANDARDS

| BASIC STANDARDS | | SUPPLEMENTAL STANDARDS |
|--|----------------|------------------------------|
| Lot Area, Minimum | 20,000 sq. ft. | 23.304.020– Lot Requirements |
| Usable Open Space Per Dwelling Unit, Minimum | n/a | |
| Floor Area Ratio, Maximum | 2.0 | |
| Main Building Height, Maximum | 45 ft. | 23.304.050– Building Height |
| Lot Line Setbacks, Minimum | | 23.304.030– Setbacks |
| Front | No minimum | |
| Rear | No minimum | |
| Interior Side | No minimum | |
| Street Side | No minimum | |
| Building Separation, Minimum | No minimum | |
| Lot Coverage, Maximum | 100% | |

E. **Permit Findings.** See Section 23.206.100– Permit Findings.

23.206.080 – MU-LI Mixed Use-Light Industrial District

A. **District Purpose.** The purpose of the Mixed Use-Light Industrial (MU-LI) district is to:

- 1. Implement the West Berkeley Plan Light Manufacturing District designation;

2. Encourage development of a mixed use-light industrial area for a range of compatible uses;
3. Encourage development of an area where light manufacturers can operate free from the economic, physical and social constraints caused by incompatible uses;
4. Encourage the creation and continuation of well-paid jobs which do not require advanced degrees;
5. Provide for the continued availability of manufacturing and industrial buildings for manufacturing uses, especially of larger spaces needed by medium sized and larger light manufacturers;
6. Provide opportunities for office development when it will not unduly interfere with light manufacturing uses and/or the light manufacturing building stock;
7. Provide the opportunity for laboratory development in appropriate locations;
8. Support the development of businesses which contribute to the maintenance and improvement of the environment;
9. Allow on-site ancillary retail as a tool to maintain and enhance the economic viability of manufacturers in the district; and
10. Maintain and improve the quality of the West Berkeley environment, while allowing the lawful and reasonable operation of light industrial uses.

B. Land Use Regulations.

1. **Allowed Land Uses.** See Table 23.206-1: Allowed Land Uses in Manufacturing Districts.
2. **Use Permit Not Required.** An existing use in the MU-LI district may be modified or intensified without a Use Permit if:
 - a. A Use Permit is not required by this chapter; and
 - b. The Zoning Officer determines that the modification or intensification of the use can reasonably be expected not to increase any impact regulated under environmental performance standards.
3. **Alcoholic Beverage Retail Sales.** Alcoholic beverage retail sales are allowed in the MU-LI district only when incidental to food product stores.
4. **Bus/Cab/Truck/Public Utility Depot.** A Use Permit is required for a bus/cab/truck/public utility depot in the MU-LI district if the lot is over 20,000 square feet, regardless of use floor area.
5. **Commercial Physical or Biological Laboratories.** Commercial physical or biological laboratories using Class 3 organisms are not permitted the MU-LI district. Use of Class 2 organisms are permitted only in locations at least 500 feet from a Residential District or a MU-R district.

6. **General Retail.** Allowed general retail uses the MU-LI district are limited to food product stores and building materials and garden supply stores. Other types of general retail uses are not permitted.
7. **Pharmaceuticals Manufacturing.** Pharmaceuticals manufacturing is allowed in the MU-LI district only in locations at least 500 feet from a Residential District or the MU-R district.
8. **Public Market, Open Air.** Open air markets in the MU-LI district with 5,000 square feet or less of lot area are allowed with AUP.
9. **Recycling Facilities.** Recycled materials processing and recycling redemption centers are allowed in the MU-LI district only on lots greater than 20,000 square feet.
10. **Theaters.** Only live stage performances are allowed in a theater in the MU-LI district. Motion picture theaters are not permitted.
11. **Vehicle Wrecking.** Permits required for vehicle wrecking the MU-LI district is determined by size of lot, not floor area.
12. **Vocational Schools.** A vocational school in the MU-LI district must provide training for occupations and/or industries found in the West Berkeley Plan area.
13. **Wholesale Trade Proximity to Residential Use.** For wholesale trade use in the MU-LI district otherwise allowed with a Zoning Certificate, an AUP is required to establish the use within 150 feet of a residential use in a Residential District or in the MU-R district.

C. **Additional Permit Requirements.** See Section 23.206.030– Additional Permit Requirements.

D. **Outdoor Recreation Sub-Zone.**

1. An Outdoor Recreation Sub-zone may be designated by the City Council, upon recommendation of the Planning Commission. In an Outdoor Recreation Sub-zone, parks and outdoor recreational uses are permitted with a Use Permit.
2. Properties designated as an Outdoor Recreation Sub-zone must be:
 - a. Designated specifically for outdoor recreational use in the West Berkeley Plan;
 - b. Owned or under acquisition by a public agency which is subject to the Zoning Ordinance;
 - c. At least 5 contiguous acres in area;
 - d. Not primarily occupied by a conforming use as designated in the West Berkeley Plan; and

- e. At least 1,000 feet from any other Outdoor Recreation Sub-zone.
- 3. The initial designation of an Outdoor Recreation Sub-zone expires five years from the designation date. To permit outdoor recreational uses after that date, the Council must renew the Outdoor Recreation Sub-zone designation.

E. Development Standards. See Table 23.206-12 for development standards in the MU-LI district.

TABLE 23.206-12: MU-LI DEVELOPMENT STANDARDS

| BASIC STANDARDS | | SUPPLEMENTAL STANDARDS |
|--|------------|------------------------------|
| Lot Area, Minimum | No minimum | 23.304.020– Lot Requirements |
| Usable Open Space Per Dwelling Unit, Minimum | n/a | |
| Floor Area Ratio, Maximum | 2.0 | |
| Main Building Height, Maximum | 45 ft. | 23.304.050– Building Height |
| Lot Line Setbacks, Minimum | | 23.304.030– Setbacks |
| Front | No minimum | |
| Rear | No minimum | |
| Interior Side | No minimum | |
| Street Side | No minimum | |
| Building Separation, Minimum | No minimum | |
| Lot Coverage, Maximum | 100% | |

F. Permit Findings. See Section 23.206.100– Permit Findings

23.206.090 – MU-R Mixed Use-Residential District

A. District Purpose. The purpose of the Mixed Manufacturing (MU-R) district is to:

- 1. Implement the West Berkeley Plan Mixed Residential District designation;
- 2. Support the continued development of a mixed-use district which combines residential, live/work, light industrial, arts and crafts and other compatible uses;
- 3. Strengthen residential concentrations which exist within the district;
- 4. Provide appropriate locations for a broad range of live/work activities to occur;
- 5. Provide a transitional district between the Residential Districts to the east of the district and the Manufacturing Districts to the west of the district;

6. Encourage light manufacturers and wholesalers which are compatible with a mixed use-residential district;
7. Support the development of businesses of all types which contribute to the maintenance and improvement of the environment;
8. Protect residents from unreasonably detrimental effect of nonresidential uses, such as noise, vibration, odors, smoke, fumes, gases, dust, heat and glare, to the extent possible and reasonable within a mixed-use West Berkeley context;
9. To the extent feasible, protect industrial uses, particularly light industrial uses, from unreasonable intrusions on their ability to operate lawfully; and
10. Permit retail and food service activities which are either limited and small scale, primarily serving persons living and/or working in the district, but not a citywide or regional clientele, or which are ancillary and designed to maintain and enhance the economic viability of manufacturers in the district.

B. Land Use Regulations.

1. **Allowed Land Uses.** See Table 23.206-1: Allowed Land Uses in Manufacturing Districts.
2. **Alcoholic Beverage Retail Sales.** Alcoholic beverage retail sales are allowed in the MU-R district only as ancillary sale of products produced or bottled on site with a Use Permit.
3. **Community Care Facility.** Community care facilities are allowed in the MU-R district only as a change of use. New construction is not permitted.
4. **General Retail.** Allowed types of general retail uses the MU-R district are limited to food product stores, building materials and garden supply stores, and arts and craft supplies. Other types of general retail uses are not permitted.
5. **Manufacturing Use Findings.** To approve an AUP or Use Permit to establish or expand a manufacturing use abutting one or more dwelling units located in the MU-R District, the review authority must find:
 - a. The manufacturer is capable of meeting all applicable performance standards; and
 - b. Permit conditions will specify all reasonable steps to minimize noise, odors, dust, vibration, glare and any other potential impacts on the abutting dwelling units.
6. **Mortuaries and Crematories.** Only mortuaries are permitted in the MU-R district. Crematories are not allowed.
7. **Multi-Family Dwellings.** Table 23.206-13 shows permits required for multi-family dwellings in the MU-R district.

TABLE 23.206-13: MU-R MULTI-FAMILY DWELLING PERMIT REQUIREMENTS

| NUMBER OF UNITS | PERMIT REQUIRED |
|-----------------|-----------------|
| 3 or 4 | AUP |
| 5 or more | UP(PH) |

8. Residential Uses.

- a. A Use Permit is required to establish a dwelling unit, group living accommodation, or live/work unit MU-R that is within 150 feet of:
 - i. An M or MM district; or
 - ii. A construction product manufacturing or primary product manufacturing use.
- b. To deny a Use Permit required by Paragraph (a) above, the ZAB must find that:
 - i. The proposed residential use would unreasonably interfere with existing or reasonably foreseeable adjacent land uses in the M or MM district; or
 - ii. Existing or reasonably foreseeable adjacent land uses in the M or MM district would have a material adverse effect on the proposed residential use.
- c. As a condition of approval for a Use Permit required by Paragraph (a) above, the residential property owner shall record an acknowledgement that existing or reasonably foreseeable adjacent land uses in the M or MM district may create noise, dust, odors, light/glare, and other impacts that will not be considered a nuisance if they are developed and conducted pursuant to the standards of the district.

9. **Residential Mixed-Use.** To approve an AUP or Use Permit to establish or expand of a residential mixed-use building in the MU-R district, the review authority must find that the specific combination of proposed residential and non-residential uses will not be hazardous or detrimental to persons living and/or working on the site or within the project vicinity.

C. **Additional Permit Requirements.** See Section 23.206.030– Additional Permit Requirements.

D. **Development Standards.** See Table 23.206-14: MU-R Development Standards for development standards in the MU-R district.

TABLE 23.206-14: MU-R DEVELOPMENT STANDARDS

| BASIC STANDARDS | SUPPLEMENTAL STANDARDS |
|-----------------|------------------------|
|-----------------|------------------------|

| | | |
|--|--------------------------|--|
| Lot Area, Minimum | | 23.304.020– Lot Requirements 23.304.020 |
| New Lot | No minimum | |
| Per Dwelling Unit or Live/Work Unit | 1,250 sq. ft. [1] | |
| Lot Width, Minimum | | 40 ft. |
| Usable Open Space, Minimum | | 23.304.090– Usable Open Space |
| Per Dwelling Unit | 150 sq. ft. | |
| Per Live/Work Unit | 40 sq. ft. | |
| Floor Area Ratio, Maximum | | 1.0 [2] |
| Main Building Height, Maximum | | 23.304.050– Building Height |
| Live/work | 28 ft. and 3 stories [3] | |
| Residential or mixed-use [4] | 35 ft. and 3 stories | |
| All other uses | 35 ft. and 2 stories [5] | |
| Lot Line Setbacks, Minimum | | 23.304.030– Setbacks |
| Front | 5 ft. | |
| Rear | No minimum [6] | |
| Interior Side | No minimum | |
| Street Side | 5 ft. | |
| Building Separation, Minimum | | No minimum |
| Lot Coverage, Maximum | | 100% |
| Notes: | | |
| [1] One additional dwelling unit allowed for remaining lot area between 750 and 1,250 square feet. | | |
| [2] Maximum 1.5 for buildings with 50 percent or more residential or live/work floor area | | |
| [3] Maximum 35 ft. with a Use Permit. | | |
| [4] Mixed use is defined here as a building with 50 percent or more of gross floor area used for residential (including live/work) purposes. | | |
| [5] Maximum 3 stories for arts/craft studios and light manufacturing (with no other non-residential uses) on a block without dwelling units. | | |
| [6] Minimum 5 ft. if rear of lot abuts a street. | | |
| [7] Setbacks required when abutting or confronting a Residential District. See 23.304.030.C.2. | | |

E. **Permit Findings.** See Section 23.206.100– Permit Findings.

23.206.100 – Permit Findings

- A. All Manufacturing Districts. To approve an AUP or a Use Permit in a Manufacturing District, the review authority must find that the project:
 1. Is consistent with the purposes of the district;
 2. Is compatible with the surrounding uses and buildings;
 3. Complies with the adopted West Berkeley Plan; and
 4. Meets any applicable performance standards for off-site impacts.
- B. **Additional Findings.** In addition to the findings in Section 23.206.100.A (All Manufacturing Districts), the review authority must also make the following findings to approve an AUP or Use Permit in each of the Manufacturing Districts.
 1. **M and MM Districts.** The project:
 - a. Is unlikely, under reasonably foreseeable circumstances, to induce a substantial change of use in buildings from manufacturing, wholesale trade, or warehousing uses; and
 - b. Is designed in such a manner to be supportive of the industrial character of the district. Such physical compatibility shall include materials used; facade treatments; landscaping; lighting; type, size and placement of awnings, windows, and signs; and all other externally visible aspects of the design of the building and site.
 2. **MU-LI District.** The project:
 - a. Is unlikely, under reasonably foreseeable circumstances, to induce a substantial change of use in buildings from manufacturing, wholesale trade, or warehousing uses;
 - b. Is designed in such a manner to be supportive of the industrial character of the district. Such physical compatibility shall include materials used; facade treatments; landscaping; lighting; type, size and placement of awnings, windows, and signs; and all other externally visible aspects of the design of the building and site; and
 - c. If the building and/or site is split between the MU-LI district and the C-W district, there are clear and appropriate distinctions in all design aspects between the portions of the building and site within the MU-LI district and the portions within the C-W district.
 3. **MU-R District.** The project:
 - a. Is unlikely, under reasonably foreseeable circumstances, to either induce or contribute to a cumulative change of use in buildings away from residential, live/work, light industrial, or arts and crafts uses; and

b. Is designed to be supportive of the character and purposes of the district.

23.208 SPECIAL PURPOSE DISTRICTS

Sections:

23.208.010– Specific Plan District

23.208.020– Unclassified District

23.208.010 – Specific Plan District

- A. **Purpose.** The Specific Plan (SP) district establishes allowed use and permit requirements in areas subject to an adopted Specific Plan.
- B. **Allowed Uses.** Allowed uses and permit requirements in the SP district are as established in the applicable Specific Plan.
 - 2. If the applicable Specific Plan is silent on a use allowed in another district, the use is allowed with a Use Permit.
- C. **Required Permits.**
 - 1. Before approving a permit application in a SP district, the City must approve a Master Development Plan Permit consistent with the applicable Specific Plan. To approve a Master Development Plan Permit, the review authority must make all findings required by the Specific Plan.
 - 2. Applications for a Master Development Plan Permit and subsequent required permits shall be submitted and processed in accordance with Section 23.404—Common Permit Requirements and 23.406—Specific Permit Requirements.

23.208.020 – Unclassified District

- A. **Purpose.** The purpose of the Unclassified (U) district is to:
 - 1. Implement the General Plan designations for areas included in the U district zoning classification; and
 - 2. Provide a district designation until such areas are classified into a residential, commercial, or manufacturing district.
- B. **Allowed Uses.**
 - 1. All uses not prohibited by law are permitted in the U district.
 - 2. A Use Permit is required to establish any use, consistent with the procedures in this section.
- C. **Use Permit Procedures.** The City shall review and act on Use Permit applications in the U district as follows:
 - 1. Each application shall be first submitted to the Planning Commission with the Planning Commission making a report to the ZAB. If the Planning Commission

fails to take an action on the report within 30 days after a Use Permit application is deemed complete, the ZAB will consider the application without a Planning Commission report.

2. After Planning Commission review, the ZAB shall take an action to approve, conditionally approve, or deny the application. The ZAB's decision is not effective until after action by the City Council. ZAB decisions may not be appealed.
 3. The ZAB will send a report of its decision, including findings and any conditions, together with the Planning Commission report, to the City Clerk within 14 days of final action.
 4. The City Council will review and act on the application within 30 days of the ZAB decision.
 5. The Council may affirm, reverse, or modify the ZAB decision.
- D. **Development Standards.** All development standards in the U District shall be set forth in the Use Permit, including lot size, density, building height, setbacks, building separation, lot coverage, floor area ratio (FAR), usable open space, and off-street parking.
- E. **Use Permit Findings.** To approve a Use Permit in the U district, the ZAB, Planning Commission, and City Council must all make the findings in Section 23.406.030.F—Administrative Use Permits (Findings for Approval).

23.210 OVERLAY ZONES

Sections:

23.210.010– Purpose of Overlay Zones

23.210.020– Hillside Overlay Zone

23.210.030– Civic Center District Overlay Zone

23.210.010 – Purpose of Overlay Zones

- A. **General.** An overlay zone is a defined geographic area shown on the Zoning Map where special requirements or limitations apply, in addition to the underlying base district requirements.
- B. **Conflicting Requirements.** Whenever a requirement of an overlay zone conflicts with a requirement of the underlying base district, the overlay zone requirement controls.

23.210.020 – Hillside Overlay Zone

- A. **Purpose.** The purpose of the Hillside (H) overlay zone is to:
 - 1. Implement General Plan policies for hillside development;
 - 2. Protect the safety and health of residents where steep topography, unusual street conditions and proximity to the wildland-urban interface create severe risk from wildfire.
 - 3. Protect the character of Berkeley’s hillside areas and their immediate environs;
 - 4. Give reasonable protection to views yet allow appropriate development of all property;
 - 5. Allow modifications in standard setback and height requirements when justified because of steep topography, irregular lot pattern, unusual street conditions, or other special aspects of the hillside areas.
- B. **Allowed Uses.**
 - 1. **General.** Allowed uses in the H overlay zone are the same as the underlying base district except as provided in this subsection.
 - 2. **Multiple Dwellings in R-2.** When the H overlay zone is combined with the R-2 district, multiple dwellings on a single property are not permitted.
- C. **Development Standards.**
 - 1. **General.** Development standards in the H overlay zone are the same as the underlying base district except as provided in this subsection.
 - 2. **Main Building Height.**

- a. Table 23.210-1 shows the maximum allowed building height in the H overlay zone.
- b. The Zoning Officer may approve an AUP to increase the allowed average and maximum main building height upon finding the project is consistent with the purpose of the H overlay zone as stated in 23.210.020.A (Purpose).

TABLE 23.210-1: H OVERLAY ZONE MAXIMUM ALLOWED HEIGHT

| UNDERLYING BASE DISTRICT | ALLOWED HEIGHT | | MAXIMUM STORIES |
|-------------------------------|--|---------|-----------------|
| | AVERAGE | MAXIMUM | |
| New Buildings | | | |
| R-1, R-1A, R-2, R-2A | 28 ft. | 35 ft. | 3 stories |
| R-3, R-4, R-5, R-S, C-N, C-NS | 35 ft. | 35 ft. | 3 stories |
| Residential Additions | As required by the base district or the highest existing portion of the roof, whichever is lower | 20 ft. | N/A |

- c. For a residential addition located above the lowest existing story that is partially or fully above grade, not habitable, and projects beyond the footprint of the habitable portion of the building, the average height is measured from the floor plate of the lowest habitable story. Maximum height is measured from grade in all cases.
- d. Height provisions in Section 23.304.050– Building Height apply in the H overlay zone.

3. Accessory Building Height.

- a. Accessory buildings are limited to 12 feet in average height and one story.
- b. The Zoning Officer may approve an AUP to increase the allowed height and/or stories upon finding that the proposed accessory building:
 - i. Will not be detrimental to the light, air, privacy, and view of adjacent property; and
 - ii. Is consistent with the purpose of the H overlay zone as stated in Section 23.210.020.A – Hillside Overlay Zone (Purpose).

4. **Setbacks and Building Separation.**

- a. The Zoning Officer may approve an AUP to reduce the minimum required main building lot line setbacks and the minimum required building separation in the underlying base district upon finding that the reduction is consistent with the purpose of the H overlay zone as stated in 23.210.020.A (Purpose).
- b. Setback provisions in Section 23.304.030– Setbacks apply in the H overlay zone.

23.210.030 – Civic Center District Overlay Zone

A. Purpose.

1. **General.** The general purpose of the Civic Center District (CCD) overlay zone is to implement General Plan Policy LU-22 to "Maintain the Civic Center as a cohesively designed, well-maintained, and secure place for community activities, cultural and educational uses, and essential civic functions and facilities" and Downtown Area Plan Policy LU-1.4 to "Focus City government and civic activity in the Civic Center area, and recognize Downtown's central role in providing community services."
2. **Specific.** The specific purpose of the CCD overlay zone is to:
 - a. Preserve and protect the integrity of the City of Berkeley Historic Civic Center through preservation of existing buildings and open space listed in the Civic Center Historic District;
 - b. Allow a set of uses, which are civic in nature, and support active community use;
 - c. Promote uses, which combined or individually will maintain public access to the historic buildings and resources;
 - d. Promote appropriate uses which respect the Civic Center's historic significance in unifying the community and forming a link to Berkeley's past;
 - e. Promote the cultural and architectural heritage of the Civic Center;
 - f. Preserve the Civic Center District as a place for government functions, community activities, cultural and educational uses, and civic functions and facilities; and
 - g. Promote uses which could financially support the goal of upgrading and preserving the existing historic buildings and resources.

- B. Applicability.** The CCD overlay zone boundaries are coterminous with the Civic Center Historic District designated under Municipal Code Chapter 3.24 and apply to the following parcels:

1. APN 057 201701601 (Old City Hall/Courthouse/Public Safety Building)
2. APN 057 202202000 (Veterans Memorial Building)
3. APN 057 202200600 (State Farm Insurance Building/City offices, 1947 Center Street)
4. APN 057 202100200 (Civic Center Park)
5. APN 057 202100100 (Civic Center Building)
6. APN 057 202601500 (Downtown Berkeley YMCA)
7. Portion of APN 057 202000503 which contains the Berkeley Community Theater/Florence Schwimley Little Theater
8. APN 057 202000400 (Berkeley High School)
9. APN 057 202700500 (Berkeley Main Post Office)

C. **Definitions.** The following definitions apply only in the CCD overlay zone:

1. **Live Performance Theatre.** An establishment that has a permanent stage for the presentation of live performances and entertainment and which contains an audience viewing hall or room with fixed seats.
2. **Museum.** A non-profit, permanent institution in the service of society and its development, open to the public, which acquires, conserves, researches, communicates, and exhibits the tangible and intangible heritage of humanity and its environment for the purposes of education, study, and enjoyment.
3. **Public Market.** An open air or enclosed marketplace, including a farmer's market, with multiple owner operated and/or independent merchants selling retail food items and handcrafted goods from local and regional producers, so long as:
 - a. At least 75 percent of retail space is devoted to the sale of general or specialized food products; and
 - b. No more than 25 percent of retail space is devoted to one or more of the following incidental uses:
 - i.* Owner operated and/or independent food service establishment selling food from local and regional producers; and
 - ii.* Sales of retail products from local and regional produce.

D. **Allowed Uses.**

E. Table 23.210-2 shows allowed uses and permit requirements in the CCD overlay zone. All properties in the CCD overlay zone are restricted to the uses in

F. Table 23.210-2, regardless of uses permitted in the underlying base district.

TABLE 23.210-2: CCD OVERLAY ZONE ALLOWED USES

| ALLOWED USE | REQUIRED PERMIT |
|--|------------------------|
| Libraries | UP(PH) |
| Judicial Courts | AUP |
| Museums | UP(PH) |
| Parks and Playgrounds | ZC |
| Public Safety and Emergency Services | UP(PH) |
| Government Agencies and Institutions | AUP |
| Public Schools/Educational Facilities | UP(PH) |
| Non-Profit Cultural, Arts, Environmental, Community Service and Historical Organizations | UP(PH) |
| Live Performance Theatre | UP(PH) |
| Public Market | UP(PH) |

G. Development Standards.

1. **General.** Development standards in the CCD overlay zone are the same as the underlying base district except as provided in this subsection.
2. **Building Height.** All new buildings and building additions are subject to a maximum building height of 50 feet.

DIVISION 3: CITYWIDE PROVISIONS

23.302: Supplemental Use Regulations

- 23.302.010– Purpose
- 23.302.020– General Use Regulations
- 23.302.030– Temporary Uses and Structures
- 23.302.040– Home Occupations
- 23.302.050– Bed and Breakfast Establishments in Residential Districts
- 23.302.060– Sidewalk Cafe Seating
- 23.302.070– Use-Specific Regulations

23.304: General Development Standards

- 23.304.010– Purpose
- 23.304.020– Lot Requirements
- 23.304.030– Setbacks
- 23.304.040– Building Separation in Residential Districts
- 23.304.050– Building Height
- 23.304.060– Accessory Buildings and Enclosed Accessory Structures
- 23.304.070– Unenclosed Accessory Structures in Residential Districts
- 23.304.080– Fences
- 23.304.090– Usable Open Space
- 23.304.100– Site Features in Residential Districts
- 23.304.110– Dormers
- 23.304.120– Lot Coverage
- 23.304.130– Non-Residential Districts Abutting a Residential District
- 23.304.140– Area Plans

23.306: Accessory Dwelling Units

- 23.306.010– Purposes
- 23.306.020– Applicability
- 23.306.030– Permit Procedures

23.308: Emergency Shelters

- 23.308.010– Chapter Purpose
- 23.308.020– Applicability and Nonconformities
- 0– Required Permits
- 23.308.030– Standards for Emergency Shelters

23.310: Alcoholic Beverage Sales and Service

- 23.310.010– Chapter Purpose
- 23.310.020– General Requirements Excluding Incidental Beer and Wine Service
- 23.310.030– Alcoholic Beverage Service When Incidental to Food Service

23.312: Live/Work

- 23.312.010– Chapter Purpose
- 23.312.020– Applicability
- 23.312.030– Required Permits
- 23.312.040– Standards for Live/Work
- 23.312.050– Findings

23.314: Short-Term Rentals

- 23.314.010– Chapter Purpose
- 23.314.020– Definitions
- 23.314.030– Applicability
- 23.314.040– General Regulations
- 23.314.050– Operating Standards and Requirements
- 23.314.060– Violations and Remedies

23.316: Percentage for Public Art on Private Projects

- 23.316.010– Chapter Purpose
- 23.316.020– Applicability
- 23.316.030– Definitions
- 23.316.040– General Requirements
- 23.316.050– Required Permits
- 23.316.060– In-Lieu Fees
- 23.316.070– Administrative Regulations (Guidelines)

23.318: Urban Agriculture

- 23.318.010– Chapter Purpose
- 23.318.020– Applicability
- 23.318.030– Urban Agriculture Uses and Levels of Discretion
- 23.318.040– Thresholds
- 23.318.050– Operation Standards
- 23.318.060– Complaints

23.320: Cannabis Uses

- 23.320.010– Chapter Purpose
- 23.320.020– Cannabis Retail
- 23.320.030– Commercial Cannabis Cultivation
- 23.320.040– Cannabis Manufacturers, Testing Labs, and Distributors

23.320.050– Microbusinesses

23.322: Parking and Loading

23.322.010– Chapter Purpose

23.322.020– Applicability

23.322.030– Required Parking Spaces

23.322.040– General Requirements

23.322.050– Parking Reductions

23.322.060– C-DMU Parking and Transportation Demand Management

23.322.070– Off-Street Parking Maximums for Residential Development

23.322.080– Parking Layout and Design

23.322.090– Bicycle Parking

23.322.100– On-site Loading Spaces

23.322.110– Parking Lots in Residential Districts

23.322.120– Transportation Services Fee

23.324: Nonconforming Uses, Structures, and Buildings

23.324.010– Chapter Purpose

23.324.020– General

23.324.030– Nonconforming Lots

23.324.040– Nonconforming Uses

23.324.050– Nonconforming Structures and Buildings

23.324.060– Exemptions

23.326: Demolition and Dwelling Unit Control

23.326.010– Chapter Purpose

23.326.020– General Requirements

23.326.030– Eliminating Dwelling Units through Demolition

23.326.040– Eliminating Dwelling Units through Conversion and Change of Use

23.326.050– Private Right of Action

23.326.060– Elimination of Residential Hotel Rooms

23.326.070– Demolitions of Non-Residential Buildings

23.326.080– Building Relocations

23.326.090– Limitations

23.328: Inclusionary Housing

23.328.010– Chapter Purpose and Applicability

23.328.020– General Requirements

23.328.030– Payment of In-Lieu Fees as an Alternative to Providing Inclusionary Units

23.328.040– Requirements Applicable to All Inclusionary Units

23.328.050– Inclusionary Unit Requirements for Rental Housing Projects

23.328.060– Inclusionary Unit Requirements for Ownership Projects

- 23.328.070– Special Requirements for Avenues Plan Area
- 23.328.080– Administrative Regulations
- 23.328.090– Fees

23.330: Density Bonus

- 23.330.010– Chapter Purpose
- 23.330.020– Definitions
- 23.330.030– Application Requirements
- 23.330.040– Density Bonus Calculations and Procedures
- 23.330.050– Incentives and Concessions
- 23.330.060– Waivers and Reductions
- 23.330.070– Qualifying Units
- 23.330.080– Regulatory Agreements

23.332: Wireless Communication Facilities

- 23.332.010– Chapter Purpose and Applicability
- 23.332.020– Definitions
- 23.332.030– General Requirements
- 23.332.040– Minimum Application Requirements
- 23.332.050– Location Requirements
- 23.332.060– Height Requirements
- 23.332.070– Design Requirements
- 23.332.080– Operation and Maintenance Standards
- 23.332.090– Public Information Requirements
- 23.332.100– Certification Requirements
- 23.332.110– Permits and Findings Required for Approval
- 23.332.120– Cessation of Operations

23.334: Transportation Demand Management

- 23.334.010– Chapter Purpose
- 23.334.020– Applicability
- 23.334.030– Transportation Demand Management Program Requirements
- 23.334.040– Monitoring, Reporting and Compliance

23.302 SUPPLEMENTAL USE REGULATIONS

Sections:

- 23.302.010– Purpose
- 23.302.020– General Use Regulations
- 23.302.030– Temporary Uses and Structures
- 23.302.040– Home Occupations
- 23.302.050– Bed and Breakfast Establishments in Residential Districts
- 23.302.060– Sidewalk Cafe Seating
- 23.302.070– Use-Specific Regulations

23.302.010 – Purpose

This chapter establishes land use regulations that apply in addition to regulations in Chapter 23.202—23.210 Zoning Districts.

23.302.020 – General Use Regulations

A. Accessory Uses.

1. **Long-Term Rental of Rooms in a Dwelling Unit.** Renting rooms and/or providing board in a dwelling unit to persons not living as a household is permitted by right as an accessory use in all Residential Districts. The room rental/boarding must comply with the following requirements:
 - a. Minimum time period for rental: 14 days.
 - b. Maximum number of renters: four persons.
 - c. A rented room:
 - i. Must be fully integrated within the dwelling unit such that it has interior access to the rest of the dwelling unit;
 - ii. May not have a separate kitchen; and
 - iii. May not have separate assigned street addresses.
 - d. All requirements for off-street parking must be met.
2. **Non-Processed Edibles.** The sale or donation of non-processed edibles grown or raised on the premises is permitted by right as an accessory use in all residential districts. All sale and donation activities must comply with the following requirements:
 - a. Sales and donations must be directly to the end consumer of the non-processed edibles.
 - b. Sales and donation-related activities must occur between the hours of 8am and 8pm.

- c. Sales and donation-related activities must be located either indoors or in an area generally shielded from view from the public right-of-way to the extent practical based on the accessibility of the subject lot.
- d. The sale or donation of non-processed edibles may not involve hazardous materials or processes or create offensive or objectionable noise, vibration, odors, heat, dirt, or electrical disturbance perceptible by the average person beyond the lot line of the subject lot.
- e. The sale or donation of non-processed edibles may not involve more than ten customer visits to the premises in one day.

3. Chair Massage.

- a. Chair massage is permitted by right as an accessory use when incidental to a retail use in the commercial districts and the MU-R district.
- b. No additional parking is required.

4. Commercial Uses in Residential Districts. A commercial use is allowed in a Residential District as an accessory use only if the use is specifically allowed by the Zoning Ordinance.

B. Hours of Operation.

1. **Allowed Hours.** Table 23.302-1: Allowed Hours of Operation shows allowed hours of operation for commercial uses in the commercial districts and the MU-R district.

Exceptions. The City may allow extended hours of operations with the approval of a permit as shown in Table 23.302-1.

2. **Alcohol Sales in C-T District.** A Use Permit is required in the C-T district for a business selling alcohol for off-site consumption to remain open past midnight. The Use Permit may be approved only if the business’s ABC license does not require sales of alcohol for off-site consumption to cease by midnight. The Zoning Adjustments Board (ZAB) may approve the Use Permit only upon finding that the extended hours will not generate excessive noise, traffic or parking problems affecting the well-being of the residents of the district.

TABLE 23.302-1: ALLOWED HOURS OF OPERATION

| DISTRICT | ALLOWED HOURS OF OPERATION | PERMIT REQUIRED TO EXTEND HOURS |
|---|----------------------------|---------------------------------|
| C-C, C-U | 7:00 a.m. – 12:00 midnight | AUP |
| C-N, C-E, C-NS, C-SO, C-W outside nodes | 7:00 a.m. – 11:00 p.m. | UP |

| | | |
|--|--|-----|
| C-W nodes | 6:00 a.m. – 12:00 midnight with Zoning Certificate | UP |
| C-SA | 7:00 a.m. – 12:00 midnight Sundays through Thursdays 7:00 a.m. – 12:00 Fridays and Saturday | UP |
| C-AC | 7:00 a.m. – 12:00 midnight Sundays through Thursdays 7:00 a.m. – 2:00 a.m. Fridays and Saturday | UP |
| C-T between Bancroft Way and the north side of Dwight Way | 24 hours per day 7 days a week | N/A |
| C-T between the south side of Dwight Way and Parker Street | 7:00 a.m. – 12:00 midnight | AUP |
| C-DMU | 6:00 a.m. and 2:00 a.m. | AUP |
| MU-R | 6:00 a.m. and 10:00 p.m. | AUP |

3. **C-T District Findings.** The Zoning Officer may approve an AUP to extend hours of operation in the C-T district upon finding that the extended hours will not generate excessive noise, traffic, or parking problems affecting the well-being of the residents of the district.

4. **Hours of Operation Defined.**

- a. For retail or customer-serving office commercial uses, hours of operation are those times that the business is open to customer access.
- b. For food service establishments, hours of operation include the time that the business is open for customer access to the departure of the last patron. These limitations do not apply to:
 - i. The delivery, maintenance, security, product preparation and other pre-opening activities, and
 - ii. Cleanup, shutdown, and other post-closure activities which do not involve presence of customers.
- c. For other commercial and manufacturing uses which do not involve customer access, hours of operation are those times that employees are present who are engaged in non-maintenance or security activities.

C. **Indoor Storage of Goods.** In the Commercial Districts, an AUP is required for the indoor storage of goods as an incidental use occupying over 25 percent of the gross floor area.

D. **Live Entertainment.**

Permits Required. Live entertainment incidental to a permitted use is allowed as shown in

Table 23.302-2.

TABLE 23.302-2: PERMIT REQUIREMENTS FOR LIVE ENTERTAINMENT

| ZONES | PERMIT REQUIRED | |
|--|-----------------|---------------|
| | AMPLIFIED | UNAMPLIFIED |
| C-C, C-U, C-SA, C-T, C-SO, C-DMU, C-AC | AUP | ZC |
| C-N, C-NS, C-W | UP(PH) | ZC |
| C-E | Not Permitted | ZC |
| M, MM | Not Permitted | Not Permitted |
| MU-LI, MU-R | UP(PH) | UP(PH) |

1. Allowed Activities.

- a. In the S-O district, food service establishments may have no live entertainment other than unamplified music, poetry reading, comedy or other quiet activities.
- b. In the C-NS district, food service establishments may have no live entertainment other than unamplified background music, unless a Use Permit is obtained.

E. Outdoor Uses.

- 1. **Applicability.** This subsection applies to outdoor uses including but not limited to exterior service windows, outside automatic teller machines, and the outside storage of goods, containers and/or materials.
- 2. **General.** Commercial and manufacturing uses shall be conducted solely within an interior of a building unless:
 - a. The permit as required by Paragraph 3 (Permits Required) is obtained; or
 - b. the outdoor use is specifically allowed by the Zoning Ordinance.
- 3. **Permits Required.**
- 4. Table 23.302-3: Permit Requirements for Outdoor Uses shows permits required for uses outside of a building in the Commercial and Manufacturing Districts.

TABLE 23.302-3: PERMIT REQUIREMENTS FOR OUTDOOR USES

| DISTRICT/USE CHARACTERISTICS [1] | PERMIT REQUIRED |
|---|-----------------|
| All Commercial Districts Except for C-W | |
| Not abutting a residential district | AUP |
| Abutting a residential district | UP(PH) |
| C-W | |
| Not abutting a residential district and less than 10,000 s. ft. | AUP |
| Abutting a residential district | UP(PH) |
| 10,000 sq. ft. or more | UP(PH) |
| M, MM [2] | |
| Less than 20,000 sq. ft. | ZC |
| 20,000 sq. ft. or more | AUP |
| MU-LI | |
| Less than 20,000 sq. ft. | ZC |
| 20,000 to 30,000 sq. ft. | AUP |
| More than 30,000 sq. ft. | UP(PH) |
| MU-R | |
| Not abutting a residential district | AUP |
| Abutting a residential district | UP(PH) |
| Notes: [1] Size is measured as the lot area of the outdoor activity or storage [2] In the M and MM district permits are required only for activity or storage not ancillary to a permitted use. | |

5. **C-W District.** In the C-W district, uses outside of a building must be permitted or incidental to permitted use in the district.
6. **M, MM, MU-LI Districts.** Outside uses in the M, MM, and MU-LI districts may not abut a residential district.

23.302.030 – Temporary Uses and Structures

A. Permitted By Right.

1. **Temporary Uses.** The following temporary uses are permitted by right:

- a. Using a dwelling, school, church, community center, or other facility as a polling or voting place for an election conducted by the City or other government agency.
- b. Conducting a garage, yard, or rummage sale on a residential property or a block sale of several properties. A sale may not exceed two days and is limited to one sale in any month's period of time.
- c. Temporary sidewalk sales conducted adjacent to, and in conjunction with, an approved commercial retail lease space, when all other City regulations are met.
- d. The use of a property as temporary parking during football games in the University of California Memorial Stadium under the provisions of Ordinance # 2435-N.S.
- e. A temporary retail use where:
 - i. The temporary sales are on the same property with an established commercial business holding a valid City business license; and
 - ii. The temporary sales conform with the approved permit for the commercial business.

2. **Temporary Structures.** The following accessory and temporary structures are permitted by right as long as they do not change the character of, and are in keeping with the purposes of the district in which they are located:

- a. Lines, wires, poles and devices to transmit electricity, telephone/telecommunications or cable television, including pipelines, conduits and appurtenances to containing such wires and devices. Allowed activities include installing, maintaining, undergrounding, and repairing such facilities. A Use Permit or AUP is required for wireless telecommunication antennas other than those located within the public right-of-way.
- b. Pipelines or conduits and appurtenances to transport oil, gas, sewage or water.
- c. Temporary construction offices, scaffolding, utility connections, on-site construction material yards and/or debris containers for not more than the time period authorized in a valid building permit.

B. AUP Required.

- 1. **When Required.** An AUP is required to establish, maintain, or operate a temporary use or structure not identified in Subsection A (Permitted By Right) above.

2. **Scope of Approval.** An AUP for a temporary use or structure applies only to the circumstances of the temporary use or structure existing at the time the application is granted.
 3. **Seasonal Product Sales.** Temporary seasonal product sales activity may not exceed a 45-day period and may not be established in any Residential district.
 4. **Time Period.**
 - a. The AUP shall specify the time period for the temporary use or structure, including a required ending date.
 - b. A time extension is not allowed unless approved by the Zoning Officer.
 5. **Findings.** To approve the AUP, the Zoning Officer must make the findings in Section 23.406.030.F– Administrative Use Permits (Findings for Approval). When making this finding, the Zoning Officer shall consider whether the temporary nature of the use or structure will make it not detrimental.
 6. **Appeals.**
 - a. An AUP decision for seasonal product sales of pumpkins and Christmas trees, including the temporary use of a structure for an office, may not be appealed.
 - b. All other AUP decisions for a temporary uses and structures may be appealed as provided in Chapter 23.410—Appeals and Certifications.
- C. **Violations.** Permits for temporary uses may be revoked for non-compliance with any conditions of approval and the Zoning Officer may issue an immediate cease and desist order.
- D. **Temporary Outdoor Uses on Private Property -- COVID-19 Local Emergency.**
1. **Applicability.**
 - a. This subsection is valid during and up to 90 days after a locally-declared state of emergency related to COVID 19.
 - b. An eligible business must:
 - i. Have a valid City of Berkeley Business License;
 - ii. Be located on private property in one of the following districts:
 1. Any commercial zoning district; or
 2. The Manufacturing (M) District, the Mixed Manufacturing (MM) district, or the Mixed-Use Light Industrial (MU-LI) district; and

- d. Permits issued pursuant to this subsection must be posted in plan view within the commercial establishment for which the permit has been issued.

4. Operating Standards.

- a. A business must comply with State and local regulations for normal business operations, including previously-imposed conditions of approval related to hours of operation and other conditions of approval not in conflict with the allowances in this subsection, in addition to State regulations for outdoor operations.
- b. A business must follow the Governor's Executive Orders, Public Health Orders, and the City of Berkeley Public Health Orders, including Appendices.
- c. A business must comply with American with Disabilities Act (ADA) requirements and the Berkeley Building Code.
- d. A Temporary Outdoor Use must maintain a 10-foot setback adjacent to any property in a residential district.
- e. A Food Service Establishment with incidental beverage service must comply with all applicable regulations of the California Department of Alcohol Beverage Control and obtain a COVID-19 temporary catering authorization.
- f. Operating Hours for a Temporary Outdoor Use are limited to 9 a.m. to 9 p.m. Operating Hours include the time that the business is open for customer access to the departure of the last patron.
 - i. Operating Hours limitations do not apply to delivery, maintenance, security, product preparation and other pre-opening activities, and cleanup, shutdown and other post-closure activities which do not involve the presence of customers.
- g. Temporary Outdoor Uses must be conducted in a manner that protects the residential character of surrounding neighborhoods from adverse impacts, including, but not limited to, commercial noise and offensive odors.
- h. Smoking is prohibited in areas designated for Temporary Outdoor Uses (BMC Section 12.70.030).
- i. Temporary outdoor lighting fixtures must be oriented in a manner to direct light away from adjacent parcels.

5. Sanitation.

- a. A business must provide garbage, recycling and compost services in accordance with the Alameda County Mandatory Recycling Ordinance.
- b. A Food Service Establishment must provide restrooms and sanitation during hours of operation.

- c. A Food Service Establishment must comply with BMC Ch. 11.64 (Single Use Foodware and Litter Reduction).
6. **Existing Parking and Loading.** Non-residential parking and loading requirements on private property are temporarily suspended if a Temporary Outdoor Use displaces areas designated for these purposes.
7. **Temporary Fixtures and Structures.**
- a. Movable fixtures such as tables and chairs, umbrellas, heaters, generators, trucks or trailers must be stored in a secure place on private property when not in use.
 - b. Fixed structures, such as semi-permanent tents, shipping containers, portable sinks and toilets, must occupy no more than 50% of the outdoor space dedicated to a Temporary Outdoor Use, in order to allow for social distancing.
 - c. The location, type and operation of Temporary Fixtures and Structures must comply with requirement of, and be inspected by, the Building and Safety Division, Health Department, Fire Department, Police Department and/or Public Works Department, as applicable.
8. **Safety.**
- a. If a Temporary Outdoor Use is located within an active parking lot, a business must provide temporary barriers to separate vehicle traffic from pedestrians and commercial activity.
 - b. If a Temporary Outdoor Use fully occupies a parking lot, a business must provide temporary barriers to prevent vehicle traffic from entering the parking lot.
9. **Remedies.**
- a. A Zoning Certificate for a Temporary Outdoor Use may be revoked for non-compliance with any conditions in this subsection, and the Zoning Officer may issue a cease and desist order immediately.
 - b. A Temporary Outdoor Use that meets the nuisance criteria set forth in 23.414.404.B (Nuisances Prohibited) is subject to abatement, a set forth in 23.414 (Nuisance Abatement).

23.302.040 – Home Occupations

A. Definitions.

1. **Home Occupation.** A home occupation is a business use conducted on property developed with Residential use, which is incidental and secondary to the residential use, does not change the residential character of the residential use, is limited so as not to substantially reduce the residential use of the legally

established dwelling, accessory dwelling unit, accessory building, or group living accommodation room and is operated only by the residents of the subject residence. There are three classifications of Home Occupations. For the purposes of this section, a “customer” is considered a single paying customer, but may include more than one person receiving the services at the same time:

- a. **Class I Home Occupations.** A Class I home occupation involves no more than five customer visits per day, with no more than four persons receiving services at a time. This class does not allow shipping of goods directly from the subject residence.
- b. **Class II Home Occupations.** A Class II home occupation involves no more than ten customer visits per day, with no more than four persons receiving services at a time and no more than one non-resident engaging in business-related activities on-site. This class does not allow shipping of goods directly from the subject residence.
- c. **Class III Home Occupation.** A Class III home occupation involves one or both of the following:
 - i. More than ten customer visits per day, with no more than four persons receiving services at a time and no more than one non-resident engaging in business-related activities on-site.
 - ii. Shipping of goods directly from the subject residence regardless of the number of customer visits per day.

2. **Permits Required.** Table 23.302-4 shows permits required for home occupations.

TABLE 23.302-4: PERMIT REQUIREMENTS FOR HOME OCCUPATIONS

| HOME OCCUPATION | PERMIT REQUIRED |
|--|-----------------|
| Class I | ZC |
| Class II | AUP |
| In the Hillside Overlay | Not Permitted |
| ES-R District | Not Permitted |
| Class III | |
| All Commercial Districts and MU-R District | UP (PH) |
| All other Districts, and in the Hillside Overlay | Not Permitted |

3. **Additional Findings -- Class II and Class III Home Occupations.** To approve an AUP for a Class II home occupation or a Use Permit for a Class III home

occupation, the Zoning Officer or the ZAB must make the permit findings in Section 23.406 (Specific Permit Requirements) and find that, based on the circumstances of the specific use and property:

- a. The degree of customer visits will not cause a significant detrimental impact on the availability of parking spaces in the immediate vicinity of the home occupation; and
- b. The degree of shipping and delivery activity to and from the subject residence will be compatible with surrounding residential uses and will not cause a significant detrimental impact on pedestrian and bicyclist safety or the availability of parking spaces in the immediate vicinity of the home occupation; and
- c. If the proposed home occupation will require a loading space on a regular basis, such loading space will be available on the subject property or the use of an on-street loading space will not cause a significant detrimental impact on pedestrian and bicyclist safety or the availability of parking spaces in the immediate vicinity of the home occupation; and
- d. The degree of customer visits and shipping and delivery activities shall not cause a detrimental impact to public safety, as determined by the Fire Marshall.

B. General Provisions.

1. **Where Allowed.** A home occupation is allowed in any dwelling unit, accessory dwelling unit, accessory building, or group living accommodation room.
2. **Incidental Use.** A home occupation in compliance with this section is considered a lawful incidental use of a primary residence and is not considered a change of use thereof.

C. Standards for All Home Occupations. The following standard apply to all home occupations.

1. A home occupation is allowed as an incidental use within a dwelling unit, accessory dwelling units, accessory building, or group living accommodation room.
2. No firearm/munitions business may operate as a home occupation
3. Customer visits are not allowed in the ES-R district.
4. A Home Occupation may occupy no more than the greater of: 400 square feet or 20 percent of the gross floor area of the dwelling unit, accessory dwelling units, accessory building, or group living accommodation room from which it operates.

5. Only residents of the subject dwelling unit, accessory dwelling units, accessory building, or group living accommodation room, who live in the unit or room full-time, may operate a home occupation business.
6. Customer visits may occur only between the hours of 10am and 8pm.
7. Storage, services, repairs and other business activities, other than permitted arrival and departure of customers and goods in transit, may not be conducted outdoors.
8. A home occupation shall not involve hazardous materials or waste as defined by Municipal Code Section 15.08.060 (Hazardous Materials or Waste), or any other materials or waste that is deemed by the Hazardous Material Manager (or their designee or successor) to be inappropriate or unsafe in a residential setting.
9. A home occupation shall not create offensive or objectionable noise, vibration, odors, smoke, heat, dirt, electrical or other disturbance perceptible by the average person beyond the unit in which the home occupation is permitted.
10. No on-site signs identifying or advertising the home occupation are allowed.
11. The operator of a Home Occupation shall pay gross receipts tax pursuant to the City's business license tax ordinance in Municipal Code Chapter 9.04 (Business Licenses).
12. A lessee in possession of a property may apply for a permit without the property owner's signature; however, home occupations are not exempt from conditions in rental and lease agreements which may limit or prohibit home occupations.

D. Complaints and Imposition of Conditions.

1. **General.** Home occupations are subject to review, the imposition of conditions, or revocation. Violations may be addressed by issuing an administrative citation pursuant to Chapter 1.28.
2. **Class I and Class II Home Occupations.** The Zoning Officer shall review documented complaints, business operations, and other factors when reviewing Class I and Class II home occupations, and may impose conditions as may be necessary to prevent detrimental effects, or may revoke the permit if adequate conditions of approval are not available.
3. **Class III Home Occupations.** The ZAB shall review documented complaints, business operations, and other factors when reviewing Class III home occupations and may impose conditions as may be necessary to prevent detrimental effects, or may revoke the permit if adequate conditions of approval are not available.

23.302.050 – Bed and Breakfast Establishments in Residential Districts

A. Section Purpose.

1. The purpose of this section is to sanction the time-limited continued operation of bed and breakfast establishments (B&Bs) in residential districts that meet the requirements in this section.
2. This section is intended solely to alleviate the hardship that might occur if the owners of B&Bs were required to cease operation immediately, as would otherwise be required by the Zoning Ordinance.
3. The purpose of this section is not to permanently legalize such B&Bs.

B. Continued Operation

1. **Eligibility.** B&Bs in operation in Berkeley as of December 13, 2003 are eligible for continued operation subject to this section if, and only so long as, they satisfy the following conditions:
 - a. The B&B has been in consistent operation since January 1, 2003.
 - b. The building or buildings of which the B&B consists are legally constructed and comply with all applicable building, fire and housing code requirements, or are brought into compliance with those requirements within a reasonable time, as determined by the City.
 - c. The B&B complies with all laws related to food service and food handling.
 - d. There is no City record of complaints about the B&B within the three years before January 1, 2003.
2. **Application.** To be granted continued operation under this section, owners of eligible B&Bs must:
 - a. Apply for continued operation no later than 90 days after November 13, 2003;
 - b. Identify all owners and operators of the B&B; and
 - c. Pay all transient occupancy and business license taxes, penalties and interest due and owing, as determined by the City Council.

C. Regulations. B&Bs that are allowed to continue in operation under Subsection B (Continued Operation) above shall comply with the following requirements.

1. The owner of the property on which the B&B is located must live there as their primary residence and must be the primary operator of the B&B.
2. No part of a B&B may be rented for social events or functions.
3. A B&B may not be expanded beyond the number of rooms or units in existence as of January 1, 2003.

4. Food service, if provided by the operator, may be provided only to paying guests.
5. A B&B shall comply with all applicable laws, ordinance and regulations concerning the preparation and service of food.
6. A B&B shall comply with all applicable disability access requirements.
7. A B&B shall pay all transient occupancy and business license taxes as they become due.

D. Determinations by City Manager.

1. The City Manager or his/her designee shall make the determinations required by this section, and their decision shall be final.
2. The City Manager may give applicants under this section a reasonable period, but not to exceed six months, in which to bring the B&B into compliance with the requirements of Subsections B (Continued Operation) and C (Regulations).

E. Status of B&B Uses Under This Section.

1. Any continued operation allowed under this section does not constitute a permit and shall not run with the land, but is limited to the owner(s)/operator(s) thereof identified under Subsection B.2 (Application) and is subject to the requirements in this section.
2. A B&B sanctioned by this section shall be treated as a lawful nonconforming use, subject to automatic termination of the B&B use as provided in this section.
3. The owner shall file a deed restriction with the County Recorder, in a form approved by the City's Zoning Officer, notifying purchasers of the effect of this section.

F. Future Regulations Applicable. By seeking and accepting continued operation under this section, and thereafter operating a B&B, owners of B&Bs expressly agree that they will be subject to any and all additional regulations that may be adopted by the City to permit and regulate new B&Bs, to the extent the City so requires.

G. Automatic Repeal. If the limitation of Subsection E (Status of B&B Uses Under This Section) above is declared unlawful or invalidated by any court of competent jurisdiction, this section shall be deemed automatically repealed, and all B&B uses sanctioned by it shall immediately terminate.

23.302.060 – Sidewalk Cafe Seating

A. Section Purpose and Intent.

1. This section establishes a process to terminate an AUP previously issued for sidewalk cafe seating and identifies new permits required for this use.

2. It is the intent of the City to discontinue issuance of new and terminate existing AUPs for sidewalk cafe seating because the City did not intend to create a land use entitlement which ran with the land for this use, which occurs on the public right-of-way. The City also intends to eliminate the discretionary aspect of permit issuance for sidewalk cafe seating and to simplify the permit process by incorporating specific, identifiable standards for issuance of permits.

B. Termination of AUPs for Sidewalk Cafe Seating.

1. **Automatic Termination.** Without any action required by the City, an AUP for sidewalk cafe seating terminates upon:
 - a. The abandonment, revocation, or termination of the food service establishment which the sidewalk cafe seating serves;
 - b. The replacement of the food service establishment with another use; or
 - c. The transfer of ownership of the food service establishment.
2. **Termination by Zoning Officer.**
 - a. After providing reasonable notice and an opportunity to be heard, the Zoning Officer may terminate an AUP for sidewalk cafe seating upon determining that the permit holder has not complied with the terms of the AUP or any applicable requirement of the Zoning Ordinance.
 - b. A decision by the Zoning Officer to terminate an AUP for sidewalk cafe seating may be appealed in accordance with Chapter 23.410 (Appeals and Certification).

C. New Permit Required.

1. After an AUP for sidewalk cafe seating is terminated, the sidewalk cafe seating may continue or resume only after the food service establishment obtains a permit under Municipal Code Chapter 14.48 (Miscellaneous Use of Streets and Sidewalks).
2. Any sidewalk cafe seating that does not obtain required permits is a prohibited encroachment under Municipal Code Chapter 16.18 (Right-Of-Way Encroachments and Encroachment Permits).

23.302.070 – Use-Specific Regulations

A. Adult-Oriented Businesses.

1. **General Limitations.** An adult-oriented business may not be established:
 - a. Within 300 feet of the boundary of a Residential District, as measured along the public right-of-way;
 - b. Within a radius of 1,000 feet from any other adult-oriented business; or

c. Within a radius of 600 feet of any public park, public health clinic, public library, school or religious assembly use.

2. **District Limitations.** Adult-oriented businesses are not permitted:

- a. On lots with frontage on San Pablo Avenue in the C-W district; and
- b. On public-serving frontages in the C-DMU district.

B. Amusement Devices Arcade.

- 1. **Distance from Schools.** An amusement device arcade may not be established within a radius of 600 feet of a primary or secondary school.
- 2. **Incidental Use.** Table 23.302-5 shows permits required and maximum number of amusement devices allowed as an incidental use in the non-residential districts.

TABLE 23.302-5: PERMIT REQUIREMENTS FOR AMUSEMENT DEVICES AS INCIDENTAL USES

| DISTRICT | PERMIT REQUIRED | MAXIMUM NUMBER |
|-------------------------|-----------------|----------------|
| C-C, C-U, C-N, C-T, C-W | AUP | 3 |
| C-E, C-NS, C-SA, C-SO | UP(PH) | 3 |
| MU-LI | AUP | No max. |
| MU-R | AUP | 3 |
| M, MM | Not Permitted | |

C. Columbaria. Columbaria require the permits shown in Table 23.302-6.

TABLE 23.302-6: COLUMBARIA PERMIT REQUIREMENTS

| PROJECT | PERMIT REQUIRED |
|---|-----------------|
| Columbaria that are incidental to a community and institutional use, limited to 400 niches, no more than 5% of the subject property area, and located in the main building. | ZC |
| All other columbaria | AUP |

D. Firearms/Munitions Business. In all districts, a firearms/munition business is not permitted on a property containing a residential use.

E. Food Service Establishments.

- 1. **Maximum Size in R-SMU.** Food service establishments in the R-SMU district may not exceed 1,200 square feet.

2. **Permits Required in Commercial Districts.** Table 23.302-7 shows permits required for food service establishments in the commercial districts.

TABLE 23.302-7: PERMIT REQUIREMENTS FOR FOOD SERVICE ESTABLISHMENTS

| DISTRICT/USE SIZE | PERMIT REQUIRED |
|--|-----------------|
| C-C, C-U, C-T, C-W | |
| Under 1,500 sq. ft | ZC |
| 1,500 sq. ft. or more | AUP |
| C-N, C-NS, C-SA, C-SO | |
| Under 1,000 sq. ft | ZC |
| 1,000 sq. ft. or more | AUP |
| C-AC, South Shattuck and North Adeline Subareas | |
| 3,000 sq ft or less | ZC |
| Over 3,000 sq ft | AUP |
| C-AC, South Adeline Subarea | |
| 1,500 sq ft or less | ZC |
| Over 1,500 sq ft | AUP |
| C-E | AUP [1] |
| C-DMU | |
| Under 3,000 sq. ft outside the Arts District Overlay | ZC |
| 3,000 sq. ft. or more | AUP |
| Any size within the Arts District Overlay | AUP [2] |
| Notes: | |
| [1] All food service uses in the C-E district require an AUP and may not be considered as an incidental use except when accessory to a food product store. | |
| [2] See 23.204.130.D.3 for required findings. | |

3. **Notification of Decision.** Food service establishments requiring an AUP in the C-N, C-E, C-NS, C-SA, C-SO districts must provide public notification of decision (NOD) within a 300-foot radius of the subject property.
4. **Carry Out Limitations in C-U District.** Food service establishments in the C-U district that exclusively sell food for offsite consumption are not permitted at any location on University Avenue between Oxford Street and Martin Luther King Jr. Way until a Downtown Retail Plan is adopted by the City Council.

5. Outdoor Cafe Seating.

- a. Outdoor cafe seating on private property outside of the public right-of-way is allowed in the commercial districts with the following permits:
 - i.* Zoning Certificate when seating does not abut a residential district.
 - ii.* AUP when seating abuts a residential district.
- b. Outdoor seating is not permitted for food service establishments in the MU-LI District.
- c. Sidewalk cafe seating within the public right-of-way is subject to 23.302.060 (Sidewalk Cafe Seating).

6. Building Openings – C-E and C-NS Districts. Food service establishments in the C-E and C-NS districts may have no openings, other than fixed windows and required fire exits, within 50 feet of a residential district.

7. C-W District Requirements.

- a. Food service drive-through is not permitted on properties fronting San Pablo Avenue.
- b. To approve a Use Permit for a food service establishment on a lot with frontage on San Pablo Avenue, the ZAB must find that:
 - i.* The project does not conflict with the goals and policies of the C-W district;
 - ii.* The location, size, appearance and signage of the project will not adversely affect the San Pablo Avenue corridor;
 - iii.* The project supports pedestrian-oriented development;
 - iv.* The project is designed to protect the residential character of surrounding neighborhoods from the adverse impacts of fast food development, including, but not limited to increased traffic, litter, and noise; and
 - v.* For projects which include construction of new buildings, the project design:
 - 1. Provides intensity of development which does not underutilize the property; especially at or near intersections of major streets;
 - 2. Provides pedestrian scale and siting; and
 - 3. Incorporates continuity in street facades.

8. Permits Required in Manufacturing Districts. Table 23.302-8 shows permits required for food service establishments in the manufacturing districts.

TABLE 23.302-8: PERMIT REQUIREMENTS FOR FOOD SERVICE ESTABLISHMENTS IN MANUFACTURING DISTRICTS

| USE TYPE AND SIZE | DISTRICT | | | |
|--|----------|-----------|---------|---------|
| | M | MM | MU-LI | MU-R |
| Incidental Use | | | | |
| Under 20,000 sq. ft. | AUP [1] | AUP [1,2] | AUP [1] | AUP [1] |
| 20,000 sq. ft. or more | - | - | - | AUP |
| Carry Out Food Service (Primary Use) | | | | |
| Under 5,000 sq. ft. | - | - | AUP | AUP |
| 5,000 sq. ft. or more | - | - | UP | UP |
| Quick Service Restaurant (Primary Use) | | | | |
| Under 5,000 sq. ft. | - | - | AUP | AUP |
| 5,000 sq. ft. or more | - | - | UP | UP |
| Full-Service Restaurant (Primary Use) | | | | |
| | - | - | UP | UP |
| Notes: [1] Outdoor food service is not permitted. [2] Limited to food or beverage for immediate consumption. | | | | |

9. MU-LI and MU-R District – Findings.

- a. To approve an AUP or Use Permit to establish or expand a food service establishment in the MU-LI or MU-R district, the review authority must find that the establishment of the use, given its size, location, physical appearance and other relevant characteristics, will not have a significant detrimental impact on the industrial character of the area.
- b. To approve an AUP for a food service establishment less than 5,000 square feet, the Zoning Officer must find that a substantial portion of the food consists of goods manufactured on site.

F. Non-Chartered Financial Institutions.

- 1. No more than four non-chartered financial institutions are permitted in the city.
- 2. Non-chartered financial institutions may not be located within a radius of 1,320 feet of another non-chartered financial institutions.

G. Parking Lot/Structure.

- 1. **Permits Required.**

2. Table 23.302-9 shows required permits for the exclusive or primary use of a lot for off-street parking spaces.

TABLE 23.302-9: PERMIT REQUIREMENTS FOR PARKING LOTS/STRUCTURES

| DISTRICT | PERMIT REQUIRED |
|--|--|
| Residential Districts | |
| R-3 | Use Permit for all parking lots and structures. [1] |
| R-S, R-SMU | Use Permit for parking structures only. Parking lots are not permitted. |
| All other residential districts | Use Permit for all parking lots and structures. |
| Commercial Districts | |
| C-C, C-U | Zoning Certificate for parking lots and structures with 5 spaces or fewer. Use Permit for more than 5 spaces. |
| C-SO | AUP for parking lots and structures with 5 spaces or fewer. Use Permit for more than 5 spaces. |
| C-DMU | AUP for parking lots with 8 spaces or fewer. Use Permit for all parking structures. Lots with more than 8 spaces not permitted. |
| C-N, C-E, C-NS, C-SA | Use Permit for all parking lots and structures. |
| C-T | Use Permit for all parking structures. All parking lots not permitted. |
| C-W | AUP for parking lots and structures with 10 spaces or fewer. Use Permit for parking lots and structures with more than 10 spaces. |
| Manufacturing Districts | |
| M, MM | AUP for parking lots and structures with 10 or fewer spaces exclusively for uses in the district. Use Permit for parking lots and structures with any number of spaces not exclusively for uses in the district. |
| MU-LI | Zoning Certificate for parking lots and structures with 10 or fewer spaces exclusively for uses in the district. AUP for parking lots and structures with 11 spaces or more exclusively for uses in the district. Use Permit for parking lots and structures with any number of spaces not exclusively for uses in the district. |
| MU-R | Zoning Certificate for parking lots and structures exclusively for uses in the district. Use Permit for parking lots and structures not exclusively for uses in the district. |
| Notes: [1] Parking lots and structures in the R-3 district are not permitted within the Southside | |

Plan area

3. **Residential District Standards.** See 23.322.110– Parking Lots in Residential Districts for standards that apply to the exclusive or primary use of a lot for off-street parking spaces in a residential district.

H. **Senior Congregate Housing.** Table 23.302-10 shows permits required for senior congregate housing.

TABLE 23.302-10: PERMIT REQUIREMENTS FOR SENIOR CONGREGATE HOUSING

| PROJECT | PERMIT REQUIRED |
|--|-----------------|
| Change of use from an existing dwelling unit to accommodate six or fewer people | ZC |
| Change of use from an existing dwelling unit to accommodate seven or more people | AUP |
| New construction to accommodate any number of people | UP(PH) |

I. **Smoke Shops.** In all districts, smoke shops are not permitted within 1,400 feet of a school or public park.

J. **Warehouse Storage for Retail Use.**

1. In all districts where retail uses are allowed, on-site storage of goods is allowed as an accessory use to a primary retail use on the lot.
2. The storage of goods for a contiguous and directly accessible retail space is allowed in the MU-LI and MU-R districts subject to the following:
 - a. An AUP is required for storage 3,000 square feet or less; a Use Permit is required for storage more than 3,000 square feet.
 - b. Except for food product stores in the MU-LI district, the storage is permitted only for uses within the district. Storage for retail uses wholly or partially outside the district is not permitted.

23.304 GENERAL DEVELOPMENT STANDARDS

Sections:

- 23.304.010– Purpose
- 23.304.020– Lot Requirements
- 23.304.030– Setbacks
- 23.304.040– Building Separation in Residential Districts
- 23.304.050– Building Height
- 23.304.060– Accessory Buildings and Enclosed Accessory Structures
- 23.304.070– Unenclosed Accessory Structures in Residential Districts
- 23.304.080– Fences
- 23.304.090– Usable Open Space
- 23.304.100– Site Features in Residential Districts
- 23.304.110– Dormers
- 23.304.120– Lot Coverage
- 23.304.130– Non-Residential Districts Abutting a Residential District
- 23.304.140– Area Plans

23.304.010 – Purpose

This chapter contains development standards that apply generally in Berkeley.

23.304.020 – Lot Requirements

A. All Districts.

1. **Lot Changes.** A lot may not be subdivided or reduced in size and a lot line may not be adjusted or redrawn in a manner that conflicts with the Zoning Ordinance or:
 - a. Reduces the lot area, lot width, or lot depth below the district minimum requirement;
 - b. Reduces the area per dwelling unit, area for off-street parking spaces, or usable open space area below the district minimum requirement;
 - c. Reduces the setback or driveway dimension below minimum district requirements for any existing building; or
 - d. Creates a building site where setbacks or driveways for a new building would require a Use Permit or Variance.
2. **Transactions Contrary to Minimum Lot Size Requirements.** Any deed of conveyance, sale or contract to sell made contrary to the minimum lot size requirements of the Zoning Ordinance is voidable at the sole option of the grantee, buyer or person contracting to buy, their heirs, personal representative or trustee in insolvency or bankruptcy within one year after the date of execution of the deed of conveyance, sale, or contract.

3. **Front Lot Line Determination for Corner Lots.** For the purpose of determining lot frontage and setback requirements, the shorter of the two intersecting lot lines along the rights-of-way of a corner lot is considered the front of the lot. For lots with equal frontage, or for irregularly shaped corner lots, the Zoning Officer shall designate the front lot line in a manner to best promote the orderly development of the immediate area.
4. **Condominium Lots.** For condominium projects with a common area, all buildings and the common area together are treated as a single lot for the purpose of calculating minimum lot size, setback, density, FAR, coverage, usable open space and off-street parking requirements.
5. **Projections Over Lot Lines.** A building or structure may not project over a lot line except that:
 - a. Awnings and other architectural features may project over a lot line into the public right-of-way, and
 - b. Fences may be erected on shared lot lines.

B. Residential Districts.

1. **Lot Line Designations for Flag and Irregular Lots.** The Zoning Officer shall designate the front, side, and rear lot line for flag lots and irregular interior lots in a manner to best protect light, air, and privacy.

23.304.030 – Setbacks

- A. **All Districts.** A building or structure may not project into a required setback area except as specifically permitted by the Zoning Ordinance.

B. Residential Districts.

1. **Corner Lots with a Rear Lot Line Abutting a Key Lot.** For corner lots in the R-1, R-1A, R-2 and R-2A districts with a rear lot line abutting a key lot, the minimum street side setback is either:
 - a. One-half the front setback required or existing on the key lot, whichever is less; or
 - b. Four feet if the corner lot maintains 50 feet or more rear setback.
2. **Setback Reductions.** Lot line setback reductions are only permitted as shown in Table 23.304-1. Otherwise, they are not permitted.

TABLE 23.304-1: ALLOWED SETBACK REDUCTIONS IN RESIDENTIAL DISTRICTS

| DISTRICT WHERE ALLOWED | WHEN ALLOWED | MINIMUM SETBACK WITH REDUCTION | REQUIRED PERMIT | REQUIRED ADDITIONAL FINDINGS [1] |
|---------------------------------|--|--------------------------------|-----------------|---|
| Front Setback Reductions | | | | |
| ES-R | On any lot | No minimum. | UP(PH) [2] | The reduced setback is: 1) necessary to allow economic use of property due to the size, shape of the lot or the topography of the site; and 2) consistent with the ES-R district purpose. |
| R-S; R-SMU | On any lot | No minimum | AUP | The reduced setback is appropriate given the setbacks and architectural design of surrounding buildings |
| R-SMU | For either: 1) a main building with dwelling units or group living accommodations; or 2) any building north of Durant Avenue | No minimum | AUP | The reduced setback is appropriate given the setbacks and architectural design of surrounding buildings |
| Rear Setback Reductions | | | | |
| ES-R [3] | On any lot | No minimum | UP(PH) [2] | The reduced setback is: 1) necessary to allow economic use of property due to the size, shape of the lot or the topography of the site; and 2) consistent with the ES-R district purpose. |
| R-1, R-1A | On a lot less than 100 ft. deep | 20% of lot depth | ZC | None |

| DISTRICT WHERE ALLOWED | WHEN ALLOWED | MINIMUM SETBACK WITH REDUCTION | REQUIRED PERMIT | REQUIRED ADDITIONAL FINDINGS [1] |
|--------------------------------------|--|---|-----------------|---|
| R-1A | To construct a dwelling unit | 12 ft. | AUP | The unit would not cause a detrimental impact on emergency access; or on light, air or privacy for neighboring properties. |
| R-2, R-2A, R-3, R-4, R-5, R-S, R-SMU | On a lot with two or more main buildings with dwelling units | No minimum | AUP | No additional findings |
| R-SMU | For either: 1) a main building with dwelling units or group living accommodations; or 2) any building north of Durant Avenue | No minimum | AUP | The reduction is appropriate given the setbacks and architectural design of surrounding buildings |
| Side Setback Reductions | | | | |
| ES-R [3] | Any lot | No minimum | UP(PH) [2] | The reduced setback is: 1) necessary to allow economic use of property due to the size, shape of the lot or the topography of the site; and 2) consistent with the ES-R district purpose. |
| R-1, R-1A | Lot width less than 40 ft. [4] | 10% of lot width or 3 ft., whichever is greater | ZC | None |
| R-1A | West of San Pablo Avenue to construct a dwelling unit | No minimum | AUP | The unit would not cause a detrimental impact on emergency access; or on light, air or privacy for neighboring properties. |

| DISTRICT WHERE ALLOWED | WHEN ALLOWED | MINIMUM SETBACK WITH REDUCTION | REQUIRED PERMIT | REQUIRED ADDITIONAL FINDINGS [1] |
|------------------------|--|---|-----------------|---|
| R-2, R-2A | Lot width less than 40 ft. | First and second stories: 10% of lot width or 3 ft., whichever is greater; Third story: 5 ft. | ZC | None |
| R-SMU | For either: 1) a main building with dwelling units or group living accommodations; or 2) any building north of Durant Avenue | No minimum | AUP | The reduced setback is appropriate given the setbacks and architectural design of surrounding buildings |

Notes:

[1] Findings are in addition to any AUP or Use Permit findings required in 23.406-Specific Permit Requirements.

[2] Fire Department must review and approve reduced setbacks in respect to fire safety.

[3] For lots less than 5,000 square feet, reductions are not allowed for property lines abutting a property under different ownership.

[4] Not permitted for rear main buildings in the R-1A district.

3. **Allowed Building Projections.** Table 23.304-2 shows building features which may project into a required setback. All projecting features must maintain a minimum 3-foot distance from an interior side lot line.

TABLE 23.304-2: ALLOWED BUILDING PROJECTIONS

| BUILDING FEATURE | MAXIMUM PROJECTION INTO REQUIRED SETBACK (MUST MAINTAIN 3 FT MINIMUM FROM INTERIOR SIDE LOT LINE) | | | |
|---|--|---------|---------------|-------------|
| | FRONT | REAR | INTERIOR SIDE | STREET SIDE |
| Chimneys, Water Heater Enclosures, Flues, Heating and Cooling Equipment | 2.5 ft. | 2.5 ft. | 1.5 ft. | 2.5 ft. |

| | | | | |
|--|---------|---------|---------|---------|
| Eaves, Cornices, Canopies, Awnings and Bay Windows [1] | 2.5 ft. | 2.5 ft. | 1.5 ft. | 2.5 ft. |
| Uncovered decks, porches, landings and stairs when 30 inches or more above grade at any point [2] | 6 ft. | 6 ft. | 1.5 ft. | 2.5 ft. |
| Balconies and fire escapes [1] | 6 ft. | 6 ft. | 1.5 ft. | 2.5 ft. |
| <p>Notes:</p> <p>[1] Projecting bay windows and balconies may not exceed 25% of the length of building wall to which its attached.</p> <p>[2] Uncovered decks, porches, landings and stairs less than 30 inches in height are not subject to minimum setback requirements.</p> | | | | |

4. **Accessibility for Persons with Disabilities.** Wheelchair ramps, lifts, and other structures to accommodate persons with disabilities may project into a required setback area with approval of a reasonable accommodation request. See Section 23.406.090 (Reasonable Accommodation). Preferred designs would comply with the following:
 - a. One side yard with a pedestrian pathway of at least 3 feet in width that provides access to the rear yard shall be maintained on the lot.
 - b. The projection may not block access to or encroach into any required off-street parking space or driveway leading to such space.

5. **Building Groups.** Where two or more main buildings are constructed as part of a single project, the Zoning Officer may approve an AUP to reduce the minimum side setback requirement if:
 - a. Each building is constructed on a separate contiguous lot; and
 - b. Each building satisfies the requirements of the Berkeley Fire Code and Berkeley Building Code.

6. **Subterranean Structures.**
 - a. A subterranean structure may project into required front, side, and rear setbacks if:
 - b. The structure has a roof;
 - c. The roof elevation does not exceed 3 feet above finished grade; and
 - d. The roof is landscaped and developed so as to qualify as usable open space in conformance with 23.304.090 (Usable Open Space).

- e. A subterranean structure that projects into a required setback must be setback at least 6 feet from the front, side, and rear lot lines.
7. **Solar Energy Equipment.** The Zoning Officer may approve an AUP for solar energy equipment to project into a required setback upon finding that:
- a. The projection is necessary to install the solar energy equipment;
 - b. The proposed structures and equipment are installed with the primary purpose to collect, store, and use solar energy; and
 - c. The building served by the solar energy equipment complies with the Residential Energy Conservation Ordinance (RECO).

C. Non-Residential Districts.

- 1. **Single-Use Residential Development.** Allowed setback reductions and projections in 23.304.030.B (Residential Districts) also apply to single-use residential development in a Non-Residential District.
- 2. **Lots Adjacent to Residential Districts.**
 - a. **Standards.** Table 23.304-3 shows minimum setbacks on lots in a Non-Residential District that abut or confront one or more lots in a Residential District. Required setbacks apply to structures occupied by any use, including residential-only buildings.

TABLE 23.304-3: SETBACKS ADJACENT TO RESIDENTIAL DISTRICTS

| District | Minimum Lot Line Setback when Lot Line Abuts or Confronts a Lot in a Residential District | | | |
|--|---|--|---------------|---|
| | Front | Rear | Interior Side | Street Side |
| All Commercial Districts, MU-LI | Same as required in adjacent Residential District [1] | 10 feet or 10% of the lot depth, whichever is less | 5 ft. | Same as required in adjacent Residential District [1] |
| MU-R | 10 ft. [1] | 10 feet or 10% of the lot width, whichever is less [2] | | |
| <p><u>Notes:</u></p> <p>[1] In the MU-LI and MU-R districts, setback may be reduced to the smaller of front setbacks on abutting lot with an AUP.</p> <p>[2] This applies to lots that abut or confront a lot either in a Residential District or containing one or more dwelling units.</p> | | | | |

- b. **Modifications in Commercial Districts.** For lots in a Commercial District that abut or confront one or more lots in a Residential District, the Zoning

Adjustments Board (ZAB) may approve a Use Permit to allow setbacks smaller than required in Table 23.304-2 upon finding that the reduced setback would provide greater privacy or improved amenities to a lot in the Residential District.

23.304.040 – Building Separation in Residential Districts

A. Table 23.304-4 shows permits required to reduce to minimum building separation standards in Residential Districts, and when these reductions are allowed.

TABLE 23.304-4: PERMITS REQUIRED FOR BUILDING SEPARATION REDUCTIONS IN RESIDENTIAL DISTRICTS

| DISTRICT WHERE ALLOWED | WHEN ALLOWED | PERMIT REQUIRED | FINDINGS [1] |
|--------------------------------------|---|-----------------|---|
| R-1A | On a lot with two or more main buildings with a dwelling unit | AUP | The unit would not cause a detrimental impact on emergency access; or on light, air or privacy for neighboring properties. |
| R-2, R-2A, R-3, R-4, R-5, R-S, R-SMU | On a lot with two or more main buildings with a dwelling unit | AUP | No additional findings |
| ES-R [2] | Any lot | UP(PH) | 1) The reduced building separation is necessary to allow economic use of property for residential purposes; 2) the development complies with all other applicable setback, coverage, and floor requirements; and 3) the reduced building separation is consistent with the ES-R district purpose. |

Notes:

[1] Findings in addition to AUP or Use Permit findings required in in 23.406.

[2] Fire Department must review and approve reduced setbacks in respect to fire safety.

23.304.050 – Building Height

A. **Projections Above Height Limits.** Table 23.304-5 shows features that may project above allowed height limits. For rules that apply to wireless telecommunication facilities, see Chapter 23.332 (Wireless Telecommunication Facilities).

TABLE 23.304-5: ALLOWED PROJECTIONS ABOVE HEIGHT LIMIT

| Structures Allowed Above Height Limit | Maximum Projection Above Height Limit | | Limitations | | Permit Required |
|--|---|---------------------------|--|---------------------------|-----------------|
| | Residential Districts | Non-Residential Districts | Residential Districts | Non-Residential Districts | |
| Towers, antennas, poles used for the transmission of electricity, telephone, cable television or other messages | No maximum | | None | | None |
| Flag poles, skylights, solar energy equipment, and similar structures | No maximum | | None | | None |
| Chimneys, water tanks, heating and air conditioning equipment, vents, pipes and necessary mechanical roof appurtenances | 4 ft. or the minimum height required by the Building Code [1] | No maximum | Maximum 3 ft. in width [1] | No additional limitations | None |
| Other building and site features, including but not limited to, mechanical penthouses, elevator equipment rooms and cupolas, domes, turrets and other architectural elements | No maximum | | May not exceed 15% of the average floor area of all of the building's stories. No tower or similar structure may be used as habitable space or for any commercial purpose, other than the mechanical needs of the building | | AUP |

Notes:

[1] May exceed allowed height and width with an AUP.

- B. **Rooftop Structures in Residential Districts.** Decks, railings, trellises, pergolas, and other similar structures may be built above a roof but less than the residential addition height limit of the district. These structures may exceed the residential addition height limit with an AUP.

23.304.060 – Accessory Buildings and Enclosed Accessory Structures

- A. **Applicability.** This section applies to accessory buildings and enclosed accessory structures as defined in 23.502 (Glossary). See Section 23.304.070 (Unenclosed Accessory Structures in Residential Districts) and Section 23.304.080 (Fences) and for requirements that apply to other unenclosed accessory structures and fences.

B. **All Districts.**

1. **Attached or Close to Main Building.** An accessory building or enclosed accessory structure, other than a subterranean structure, that is attached to or within 3 feet of a wall of a main building, is considered a part of the main building for the purposes of setback requirements.
2. **Demolition.** See 23.326.030.C (Accessory Buildings) and 23.326.070.B (Accessory Buildings) for permits required to demolish accessory buildings.

C. **Residential Districts.**

1. **Permits Required.** Table 23.304-6 shows permits required for accessory buildings and accessory structures in Residential Districts.

TABLE 23.304-6: PERMIT REQUIREMENTS FOR ACCESSORY BUILDINGS AND ENCLOSED ACCESSORY STRUCTURES

| District Location and Building/Structure Type | Permit Required |
|---|-----------------|
| All Residential Districts Except ES-R | |
| New accessory buildings | AUP |
| Alterations to existing accessory buildings | ZC |
| Enclosed accessory structures on a lot with a main building | ZC |
| Enclosed accessory structures on a vacant lot without a main building | AUP |
| Horse stables | AUP [1] |
| Accessory buildings and structures with Urban Agriculture | ZC |
| ES-R District | |
| Under 100 sq. ft. | ZC |

| | |
|--|--------|
| 100 sq. ft. or more | UP(PH) |
| On a vacant lot without a main building | UP(PH) |
| Notes: | |
| [1] Horse stables are not permitted in the R-S and R-SMU districts | |

2. Development and Use Standards.

- a. Development Standards.** Table 23.304-7 shows development standards for accessory buildings and enclosed accessory structures in Residential Districts.

TABLE 23.304-7: ACCESSORY BUILDING AND ENCLOSED ACCESSORY STRUCTURE STANDARDS IN RESIDENTIAL DISTRICTS

| Building/Structure Feature | Standards |
|--|--|
| Average Height, Maximum | |
| Less than 4 ft. from lot line | 10 ft. |
| 4 ft. to less than 10 ft. from lot line | 12 ft. |
| 10 ft. or more from lot line | 24 ft. |
| Setbacks, Minimum | |
| Front of Interior Lot | 50% of lot dept |
| Front of Through Lot | 25% of lot dept |
| Front of Corner Lot | The setback existing or required on the adjacent lot, whichever is smaller, <u>and</u> the existing setback of main building on the lot |
| Street Side, Corner Lot | The existing setback of main building on the lot |
| Interior Side | 4 ft. for building/structures within 75 feet of front lot line; as required by Berkeley Building Code for buildings/structures 75 feet or more from front lot line |
| Edge of Alley | 5 ft. |
| Building Length [1] | 24 ft. |
| Notes: | |
| [1] Applies to building walls generally parallel to a side lot line. | |

b. Deviation from Standards.

- i.* In all Residential Districts except for the ES-R district, the Zoning Officer

may approve an AUP to allow an accessory building or enclosed accessory structure to deviate from the standards in Table 23.304-7. In the ES-R district, deviations require ZAB approval of a Use Permit.

- ii.* To approve the deviation, the review authority must find that the proposed building or structure will not be detrimental to the light, air, privacy, and view of adjacent properties.
- c. Bathroom and Kitchen Facilities.** An accessory building may contain a full bathroom, including handwashing sink, toilet, and tub or shower, as well as cooking facilities, as long as the cooking facilities do not constitute a kitchen.
- d. Rentals.** An accessory building may be rented only as a short-term rental as allowed in Section 23.314—Short-Term Rentals.

2. Rebuilding and Replacement.

- a.** Notwithstanding the setback standards in this section and the coverage area standards in Chapter 23.202—Residential Districts, an accessory building or enclosed accessory structure may be constructed to replace a pre-existing lawful accessory building or enclosed accessory structure, if the replacement building or structure is in the same location and has the same or smaller footprint as the previous structure. However, any such replacement structure may not exceed the average height as the previous building or structure; otherwise an AUP is required.
- b.** Such replacement buildings and structures are permitted as of right only if an application for a building permit for their construction is submitted at the same time as an application for a building permit for the demolition of the pre-existing building or structure.
- c.** The demolition of any accessory building proposed for replacement under this section is subject to Municipal Code Chapter 3.24 (Landmark Preservation Commission).

D. Non-Residential Districts. The following requirements apply to accessory buildings and enclosed accessory structures in Non-Residential Districts.

1. Permits Required.

- a.** Accessory buildings and enclosed accessory structures in a Non-Residential District require the same permits as a main building in the district, except as provided in paragraphs (b) and (c) below.
- b.** Accessory buildings and structures with urban agriculture are allowed with a Zoning Certificate.
- c.** In a Commercial District, an accessory building or enclosed accessory structure associated with a residential-only project requires the same permits

as in all Residential Districts except ES-R as shown in Table 23.304-7: Accessory Building and Enclosed Accessory Structure Standards in Residential Districts.

2. Development Standards.

- a. Accessory buildings and enclosed accessory structures must comply with the same development standards that apply to main buildings in the district.
- b. A detached accessory building or enclosed accessory structure may not be erected or expanded within 5 feet of an alley.

23.304.070 – Unenclosed Accessory Structures in Residential Districts

A. Applicability. This section applies to unenclosed accessory structures as defined in 23.502 Glossary in a Residential District, excluding fences which are addressed in 23.304.080– Fences.

B. Placement on Lot. Unenclosed accessory structures require an AUP if placed on the ground within a required setback.

C. Height.

1. For unenclosed accessory structure within a required setback, allowed height shall be specified in the AUP.
2. No height limitations apply to unenclosed accessory structures outside of required setbacks.
3. The height of an unenclosed accessory structure is measured as the vertical distance from the lowest existing grade point within a 3-foot radius of any point of the structure to the highest point of the structure.

D. Hot Tubs, Jacuzzis, and Spas.

1. An unenclosed outdoor hot tub, jacuzzi, or spa located anywhere on a lot requires:
 - a. An AUP in all Residential Districts except for the ES-R district; and
 - b. A Use Permit in the ES-R district.
2. Any pump associated with an unenclosed outdoor hot tub, jacuzzi, or spa shall be mounted and enclosed so that its sound is not audible on an adjacent lot.

23.304.080 – Fences

A. Permits Required. Table 23.304-8 shows permits required for fences in all districts.

TABLE 23.304-8: PERMITS REQUIRED FOR FENCES

| District Location and Fences Height/Location | Permit Required |
|--|-----------------|
| All Districts Except ES-R | |
| 6 ft. in height or less | None required |
| More than 6 ft in height and on lot line or within required lot line setbacks for main building | AUP |
| ES-R District | |
| 4 ft. in height or less | None required |
| More than 4 ft. in height and on lot line or within required lot line setbacks for main building | AUP [1] |
| Notes: [1] Requires Fire Department review and comment. | |

B. Height Measurement. The height of a fence is measured as the vertical distance from the lowest existing grade point within a 3-foot radius of any point of the structure to the highest point of the structure.

C. Prohibited Materials in Residential Districts.

1. A fence in a Residential District may not contain strands of barbed or razor wire, sharp or jagged glass, sharp or jagged metal components (e.g., razor-spikes), or similar materials.
2. Prohibited fence materials on an existing fence may not be expanded or repaired. Table 23.304-9 shows the date by which existing non-conforming prohibited fence materials must be removed.

TABLE 23.304-9: REMOVAL OF PROHIBITED FENCE MATERIALS

| ADJUSTED MARKET VALUE OF PROHIBITED FENCE MATERIAL | REQUIRED REMOVAL DATE |
|--|---|
| \$1,500 or less | October 16, 2004 or within one year from the date such feature became non-conforming, whichever date is earlier |
| More than \$1,500 | October 16, 2005 or within one year from the date such feature became non-conforming, whichever date is earlier |

3. For purposes of this section, the adjusted market value of the existing non-conforming prohibited fence feature is calculated as follows:
 - a. The "original cost" of the fence feature is the likely cost of substantially similar fence features at the time the fence feature was initially installed plus the likely costs of installation at that time.
 - b. The "original cost" is reduced by 10 percent for each year since the fence feature was installed, until the year that this section became effective. This reduced is considered the "adjusted market value."
4. If a property owner shows that the period of time in Table 23.304-9 is unreasonable as applied to a particular fence feature, the City may extend the period within which removal of such feature is required, after weighing the harm to the public interest from continued maintenance of the fence and other relevant factors. Any such determination will be made in the course of the proceedings to abate pursuant to Municipal Code Chapter 1.24 (Abatement of Nuisances).

D. Barbed or Razor Wire in Non-Residential Districts.

1. A fence adjacent to a street, sidewalk, path, or other public right-of-way in a Non-Residential District may have strands of barbed or razor wire if:
 - a. The lowest strand is more than 5 feet above the ground; and
 - b. The strands are at least 6 inches inside the property line of a privately-owned lot.
2. A fence on a lot line that abuts a Residential District must comply with 23.304.080.D– Fences (Prohibited Materials in Residential Districts).

E. MU-R District.

1. Abutting Residential Uses.

- a. If the side or rear of a lot in the MU-R district with a residential use abuts another lot with a residential use, a fence over six feet in height must be setback at least either:
 - i.* Eight feet from any main residential building on the abutting lot; or
 - ii.* Four feet from the property line if the main residential building on the abutting lot is less than 4 feet from the abutting lot line.
- b. This requirement does not apply when two lots sharing the lot line are under the same ownership.

2. Manufacturing/Residential Buffers.

- a. If a development project in the MU-R district results in a lot with a manufacturing use abutting the side or rear of a lot with a residential use, an

8-foot minimum fence with sound absorbent material is required between the manufacturing and residential uses.

- b. The Zoning Officer may approve an AUP to allow for an alternative method to provide a buffer between the manufacturing and residential uses.

23.304.090 – Usable Open Space

A. **Applicability.** The standards in this section apply to areas used to satisfy minimum usable open space requirements as shown in Chapters 23.202–23.202.110 (Zoning Districts).

B. **Standards.**

1. **Accessibility and Use.** Usable open space shall be accessible to the occupants of the building for active or passive recreation use.
2. **Assignment to Unit.** An area which is accessible and/or usable only by the occupants of a particular dwelling unit may satisfy the usable open space area requirements only for that particular dwelling unit.
3. **Minimum Dimensions.** Except for balconies, a usable open space area must have a minimum width and length of 10 feet.
4. **Balconies.**
 - a. A maximum of 50 percent of the total required usable open space area may be satisfied by balconies.
 - b. A balcony must have a minimum width and length of 6 feet.
 - c. At least one exterior side must be open and unobstructed except for required railings.
5. **Uncovered.** Except for balconies, usable open space shall be at least 75 percent open to the sky.
6. **Slope.** Usable open space must have a slope of 8 percent grade or less.
7. **Landscaping.**
 - a. At least 40 percent of the total required usable open space area, exclusive of balconies above the ground floor, shall be landscaped.
 - b. A landscaped area may not include off-street parking spaces, driveways, paved walkways and paths, patios and other surfaces covered by concrete or asphalt.
 - c. For multiple dwelling uses, required landscaped areas shall incorporate automatic irrigation and drainage facilities adequate to assure healthy growing conditions for plants.

8. **Amenities.** Usable open space which is not planted shall be developed to encourage outdoor active or passive recreational use and shall include such elements as decks, sports courts, outdoor seating, decorative paved areas and walkways which do not serve as entrance walkways.
 9. **Access Features Not Included.** Usable open space may not contain area designated for off-street parking and loading, service areas, driveways, required walkways or other features used for access to dwelling units.
- C. **Other Open Space Areas.** Areas of the lot which do not qualify as usable open space and which are not designated as driveways, off-street parking spaces or required walkways, shall be retained as landscaped areas.

23.304.100 – Site Features in Residential Districts

- A. **Applicability.** The standards in this section apply in all Residential Districts.
- B. **Garbage Cans.** All garbage cans shall be effectively screened from view from the public right-of-way and surrounding properties.
- C. **Utility Meters.** For buildings with two or more units, all utility meters shall be effectively screened from view from the public right-of-way and surrounding properties.
- D. **Pedestrian Walkway for Multiple Dwellings.**
 1. All multi-family dwellings shall have an unobstructed walkway for pedestrian access from the public right-of-way to the building.
 2. The required walkway shall be separated and physically protected from a driveway or off-street parking spaces with a minimum 2-foot wide landscaped strip.
- E. **Exterior Lighting.**
 1. All exterior lighting shall be shielded and directed downward and away from lot lines to prevent excessive glare beyond the property on which the light is located.
 2. Lights on motion sensors may not be triggered by movement or activity located off the property on which the light is located.

23.304.110 – Dormers

- A. **Wall Setback.** All features of a dormer shall be set back at least 3 feet from the exterior of the wall below, with the exception of the dormer's eaves, which may project horizontally not more than two feet from the exterior face of the dormer.
- B. **Placement Below Roof.** A dormer must be below the ridge of the portion of the building's roof where the dormer is located.

C. Horizontal Dimension. The total horizontal dimension of the dormer(s) facing the side of a building, as measured parallel to that side, may not exceed 25 percent of the length of the exterior wall, as shown in Figure 23.304-1: Dormers.

D. Excluded from Average Height Calculation. Dormers complying with this section are not included in the average building height calculation.

FIGURE 23.304-1: DORMERS

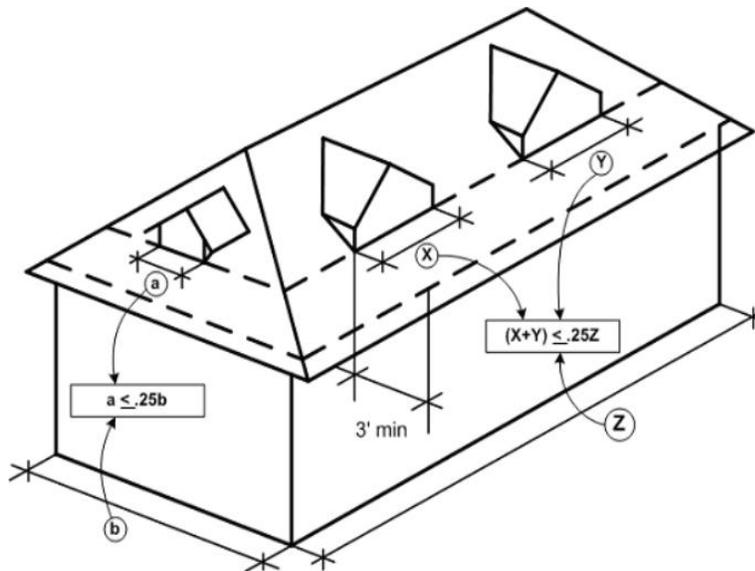

23.304.120 – Lot Coverage

- A. **Maximum Requirement.** A lot may not exceed the maximum lot coverage required in a district except as specifically permitted by the Zoning Ordinance.
- B. **Exception.** Solar energy equipment and wheelchair ramps and lifts in compliance with the Zoning Ordinance may exceed the maximum allowed lot coverage.

23.304.130 – Non-Residential Districts Abutting a Residential District

- A. **Applicability.** The standards in this section apply to lots in a Non-Residential District that abut or confront a lot in a Residential District.
- B. **Conflicting Provisions.** If the standards in this section conflict with a standard in Chapters 23.202–23.210 (Zoning Districts), the Chapters 23.202–23.210 standard governs.
- C. **Standards.**

1. **Display Window Orientation.** Display windows and customer entrances, other than required exits, shall not face abutting lots in a Residential District.
 2. **Exterior Lighting.** Exterior lighting shall be shielded in a manner which avoids direct glare onto abutting lots in a Residential District.
 3. **Lot Line Screening.** To provide screening, a solid wall or fence, measuring 6 feet in height from existing grade, shall be erected at the lot line of an abutting lot in a Residential District.
 4. **Exhaust Air Ducts.**
 - a. Exhaust air ducts shall be located or oriented to direct vented air flows away from a Residential District.
 - b. Exhaust air ducts shall include equipment to mitigate odors.
- D. **Modifications.** The ZAB may approve a Use Permit to reduce or waive the requirements of this section upon finding that requirement is unnecessary to minimize the effects of commercial uses on a lot in the Residential District.

23.304.140 – Area Plans

- E. **Downtown Area Plan.** Projects in the Downtown Area Plan boundaries are subject to the applicable mitigation measure in the adopted Mitigation Monitoring Program of the Downtown Area Plan Final EIR.
- F. **Southside Plan.**
1. **Mitigation Measures.** Projects in the Southside Plan boundaries are subject to the applicable mitigation measures in the adopted Mitigation Monitoring Program of the Southside Plan Final EIR.
 2. **Permit Findings.** To approve an AUP or Use Permit for a project in the Southside Plan boundaries, the review authority must find that the project complies with the Southside Plan's adopted Mitigation Monitoring Program (MMP).
- G. **West Berkeley Plan.** Projects in the West Berkeley Plan boundaries are subject to the applicable mitigation measure in the adopted Mitigation Monitoring Program of the West Berkeley Plan Final EIR.
- H. **Adeline Corridor Plan.** Projects in the Adeline Corridor Plan boundaries are subject to the applicable mitigation measure in the adopted Mitigation Monitoring Program of the Adeline Corridor Plan Final EIR.

23.306 ACCESSORY DWELLING UNITS

Sections:

- 23.306.010– Purposes
- 23.306.020– Applicability
- 23.306.030– Permit Procedures

23.306.010 – Purposes

The purposes of this chapter are to:

- A. Implement California Government Code Section 65852.2 and 65852.22.
- B. Increase overall supply and range of housing options in Berkeley.
- C. Expedite small-scale infill development.
- D. Support Housing Element goals of facilitating construction of accessory dwelling units and increasing the number of housing units that are more affordable to Berkeley residents.
- E. Encourage development of accessory dwelling units in zoning districts with compatible land uses and infrastructure.

23.306.020 – Applicability

- A. The provisions of this chapter apply to all lots with at least one existing or proposed dwelling unit.

23.306.030 – Permit Procedures

Zoning Certificates will be issued for Accessory Dwelling Units and Junior Accessory Dwelling Units per California Government Code Section 65852.2 and 65852.22.

23.308 EMERGENCY SHELTERS

Sections:

- 23.308.010– Chapter Purpose
- 23.308.020– Applicability and Nonconformities
- 0– Required Permits
- 23.308.030– Standards for Emergency Shelters

23.308.010 – Chapter Purpose

This chapter establishes standards for emergency shelters that ensure compatibility of shelter activities with surrounding uses and provide a safe place for individuals and families to obtain temporary shelter

23.308.020 – Applicability and Nonconformities

- A. **Applicability.** This chapter applies to all emergency shelters established after January 1, 2014.
- B. **Nonconformities.**
 1. Emergency shelters established before January 1, 2014 may continue to operate consistent with:
 - a. The conditions in those approvals and permits;
 - b. All other applicable provisions of the Zoning Ordinance; and
 - c. Any limitations and requirements imposed as a condition of funding.
 2. Except in the MU-LI district, such existing emergency shelters shall be treated as a lawful nonconforming use under Chapter 23.324(Nonconforming Uses, Structures, and Buildings). Existing shelters in the MU-LI district are not considered a nonconforming use and may add floor area with a Use Permit.

– Required Permits Table 23.308-1 shows permits required for emergency shelters.

TABLE 23.308-1: PERMIT REQUIREMENTS FOR EMERGENCY SHELTERS

| DISTRICTS | PERMIT REQUIRED [1] |
|--|---------------------|
| Residential Districts | |
| R-1, R-1A, ES-R, R-2, R-2A, R-3 | Not Permitted |
| R-4, R-5, R-S, and R-SMU | |
| 15 beds or fewer [1] | ZC |
| More than 15 beds | UP(PH) |
| Commercial Districts | |
| C-C, C-U, C-N, C-E, C-NS, C-SA, C-T, C-SO, C-W, C-AC | |

| | |
|---|---------------|
| 25 beds or fewer | ZC |
| More than 25 beds | UP(PH) |
| C-DMU | |
| 60 beds or fewer | ZC |
| More than 60 beds | UP(PH) |
| Manufacturing Districts | |
| M, MM, MU-LI, MU-R | Not Permitted |
| Notes: [1] See also permit requirements based on floor area of use in Table 23.308.040-1 | |

23.308.030 – Standards for Emergency Shelters

A. **All Districts.** The following standards apply to emergency shelters in all districts.

1. No individual or household may be denied emergency shelter because of an inability to pay.
2. No emergency shelter shall be located within 300 feet of another emergency shelter, except when a Use Permit is approved to allow less of a buffer distance.
3. When abutting a Residential District, all areas for shelter activities and uses, including but not limited to waiting and intake, personal storage, facility storage, and recreation, shall be located indoors.
4. The following emergency shelter facilities are required:
 - a. An area for onsite client intake equal to one-quarter of the area provided for client beds. This may be a multi-use area.
 - b. Showers and restroom facilities.
5. The following emergency shelter facilities are optional:
 - a. Secure personal storage.
 - b. Daytime services.
 - c. Meal services.
 - d. Communal kitchen.
 - e. Laundry equipment for clients.
 - f. Child care.
 - g. Vehicle and/or bicycle parking.

6. Lighting shall be provided in all exterior areas, including pathways, parking areas, courtyards, rear yard areas, and spaces between structures. Lighting shall be directed in a manner that does not cast light onto neighboring properties.
7. On-site management shall be provided at all times the facility is in operation and at least one hour before and after facility operation hours.
8. The shelter operator shall prepare and implement a Shelter Safety and Management Plan. The Plan shall be available to the public upon request and shall address the following:
 - a. Client congregation outside of the shelter facility to prevent queuing within the public right-of-way.
 - b. Eligibility criteria, enforcement rules, and procedures for disruptive clients.
 - c. Number and responsibilities of on-site support staff, training standards, other management procedures, and a primary and secondary contact person.
 - d. Bed bug prevention.
 - e. Refuse collection.
 - f. Security procedures.
 - g. Separation of sleeping areas and restrooms by gender and for families.
 - h. Consistency with the Alameda County-Wide Homeless Continuum of Care: Health, Safety and Accessibility Standards for Shelter Facilities in Alameda County.
9. The shelter provider shall conduct a community meeting after giving notice to all owners and occupants on record with the Alameda County Assessor within a 100-foot radius of the proposed shelter location. A community meeting shall not be required when the target population of the proposed shelter requires privacy due to safety concerns as determined by the Zoning Officer.

B. Seasonal Emergency Shelters.

1. **Seasonal Emergency Shelter Defined.** A seasonal emergency shelter is an emergency shelter that may operate only during the wet weather season from November 15 through April 15, unless the City Manager determines in any given year that the wet season has begun earlier or extended later than these dates.
2. **Standards in Residential Districts.** In addition to the standards in Subsection A (Standards for All Emergency Shelters) above, the following standards apply to seasonal emergency shelters in a residential district.
 - a. A seasonal emergency shelter must be incidental to a community and institutional use.

- b. Table 23.308-2 shows permits required based on the percentage of the community and institutional use occupied by the seasonal emergency shelter.

TABLE 23.308-2: FLOOR AREA PERMIT REQUIREMENTS IN RESIDENTIAL DISTRICTS

| PERCENT OF COMMUNITY AND INSTITUTIONAL USE FLOOR AREA OCCUPIED BY EMERGENCY SHELTER | PERMIT REQUIRED |
|---|-----------------|
| 25% or less | ZC |
| More than 25% to less than 50% | UP(PH) |
| 50% or more | Not allowed |

C. **Findings.** To approve a Use Permit for an emergency shelter under Section 23.304.030(Required Permits) or 23.308.030(Standards in Residential Districts), the Zoning Adjustments Board (ZAB) must find that:

1. A larger shelter facility will help meet the City’s goals pertaining to emergency housing of the homeless;
2. The circumstances of the subject property make the larger facility appropriate;
and
3. Design features will minimize impacts on the surrounding area.

23.310 ALCOHOLIC BEVERAGE SALES AND SERVICE

Sections:

23.310.010– Chapter Purpose

23.310.020– General Requirements Excluding Incidental Beer and Wine Service

23.310.030– Alcoholic Beverage Service When Incidental to Food Service

23.310.010 – Chapter Purpose

This chapter establishes general requirements for alcoholic beverage sales or service and permit requirements and standards for alcoholic beverage service when incidental to a food service establishment.

23.310.020 – General Requirements Excluding Incidental Beer and Wine Service

A. Applicability.

1. This section applies to any application to begin or increase alcoholic beverage sales or service, excluding beer and wine service incidental to a food service establishment in a Commercial District (see 23.310 (Alcoholic Beverage Service When Incidental to a Food Service)).
2. As used in this section, an increase in alcoholic beverage sales or service includes, but is not limited to:
 - a. Adding the sales or service of distilled spirits to any existing sales or service of beer and/or wine;
 - b. Extending the hours of operation of any establishment that sells or serves any alcoholic beverage; and
 - c. Adding to the capacity, floor area, or shelf space devoted to alcoholic beverages of any establishment that sells or serves any alcoholic beverages.
3. An increase in alcoholic beverage sales or service does not include extending the hours of operation of any food service establishments with incidental beer and/or wine service.

B. Permit Required. A Use Permit is required to begin or increase alcoholic beverage sales or service in any way.

C. Application – List of Nearby Establishments. As part of an application to begin or increase alcoholic beverage sales or service, the applicant must provide a list of all establishments within a 1,000-foot radius which are in the same category of alcoholic beverage sales or service, as defined by the California Department of Alcoholic Beverage Control.

D. Findings of Public Convenience or Necessity. If the proposed use is within a 1,000-foot radius of the site of a use that is in the same category of alcoholic beverage sales or service, excluding food service establishments with incidental

service of beer and/or wine, the Zoning Adjustments Board (ZAB) may approve the application only if it makes all of the following findings:

1. The proposed establishment will promote the City's economic health, contribute to General Plan or area plan policies, or further the district purpose.
2. The economic benefits associated with the establishment could not reasonably be achieved without the proposed alcohol sales or service.
3. If the applicant has operated a licensed establishment that has been the subject of violations regarding alcohol in the State of California, or violations of public safety or nuisance statutes or regulations in Berkeley as verified by the Police Department, such violations do not indicate a high likelihood of further violations and/or detrimental impacts from the proposed establishment. In making this finding, the ZAB may consider the number, frequency, and severity of prior violations, the time elapsed since the last violation, and other relevant factors.
4. If the proposed establishment is within 1,000 feet of any public park or public school, the ZAB has taken into consideration the effect of the proposed establishment upon such sensitive public uses.
5. The Police Department has reported that the proposed establishment would not be expected to add to crime in the area.

23.310.030 – Alcoholic Beverage Service When Incidental to Food Service

A. **Permits Required.** Table 23.310-1 shows permits required for alcoholic beverage service when incidental to a food service establishment.

TABLE 23.310-1: PERMITS REQUIRED FOR ALCOHOLIC BEVERAGE SERVICE

| District | Permit Required Based on Type of Beverages Served When Incidental to Food Service | |
|---------------------------------------|---|-------------------|
| | Beer and Wine | Distilled Spirits |
| R-SMU | UP(PH) | UP(PH) |
| All Commercial Districts, except C-AC | ZC | UP(PH) |
| C_AC | ZC | AUP |
| MU-LI, MU-R | UP(PH) | UP(PH) |

B. Use Limitations.

1. **R-SMU District.** In the R-SMU district, alcoholic beverage service is allowed only for full-service restaurants. Alcoholic beverage service is not allowed for carry out food stores and quick-service restaurants.

2. **Commercial Districts.** In Commercial Districts, beer and wine service is allowed by right when for on-site consumption with seated food service.
3. **C-NS District.** In the C-NS district, distilled spirit service is allowed only for full-service restaurants. Distilled spirit service is not allowed for carry out food stores and quick-service restaurants.
4. **C-T and C-SO Districts.** In the C-T and C-SO districts, distilled spirit service is allowed only for on-site consumption with seated food service.
5. **C-AC District.** In the C-AC district, distilled spirit service is allowed along Adeline Street south of Ashby Avenue only for on-site consumption with seated food service.

C. **Incidental Beer and Wine Service Standards.** The following standards apply to beer and wine service incidental to a food service establishment in a Commercial District.

1. **Licensing.**

- a. The food service establishment shall comply with all applicable regulations of the California Department of Alcoholic Beverage Control.
- b. An operator of the licensed establishment may not have a prior licensed establishment that was the subject of verified complaints or violations regarding alcohol, public safety, or nuisance statutes or regulations before issuance or transfer of a business license at this location.

2. **Service.**

- a. Beer and wine beverage service shall be incidental to the primary food service use.
- b. Beer and wine service incidental to seated food service shall only be allowed at a bona fide eating place making actual and substantial sales of meals as determined and required by the California Department of Alcohol Beverage Control.
- c. The sale of beer and wine for off-site consumption is not permitted.
- d. Employees may not serve beer or wine to patrons who appear to be inebriated or otherwise unable to behave in an orderly manner upon consuming alcohol.
- e. All beer and wine served to patrons must be served in durable restaurant tableware. Beer or wine may not be distributed in its original bottle or can, or in any other potentially disposable container.

- f. There shall be no bar or lounge area upon the licensed premises maintained for the sole purpose of sales, service, or consumption of alcoholic beverages directly to patrons for consumption.
- g. Hours of operation are subject to review and amendment by the ZAB as necessary to avoid detriment to the neighborhood or to achieve conformance with revised City of Berkeley standards or policies.

3. Operation.

- a. The food service establishment must operate at least five days a week.
- b. The service of beer and wine shall be limited to normal meal hours (per California Department of Alcoholic Beverage Control) during the food service establishment's hours of operation.
- c. During operating hours, 100 percent of the service area shall be designed and used for meal service and must possess the necessary utensils, and condiment dispensers with which to serve meals to the public.
- d. At no time shall the operator rent the restaurant space to a third-party.
- e. The owner or operator of the establishment shall take reasonable measures to prevent disturbances by patrons in the immediate vicinity. Such measures shall include:
 - i. Signs reminding patrons of nearby residences and requests not to congregate or loiter near such residences nor operate vehicles in a noisy manner on residential streets; and
 - ii. Surveillance to public areas near the establishment, keeping public areas free of trash and litter, providing lighting, and otherwise preventing conduct that might disturb the peace and quiet of residences in the vicinity.
- f. The operator shall assume reasonable responsibility for ensuring that patrons do not block the entrance or interfere with pedestrian activity on the adjacent public sidewalk.
- g. The applicant shall establish cash handling procedures to reduce the likelihood of robberies and theft.

4. Advertising.

- a. There shall be no exterior advertising or sign of any kind or type, including advertising directed to the exterior from within, promoting or indicating the availability of alcoholic beverages. Interior displays of alcoholic beverages or signs which are clearly visible to the exterior constitute a violation of this requirement.

- b. Alcohol-dispensing facilities and signs advertising alcoholic beverages may not be visible from the public right-of-way.

5. Training.

- a. The operator shall finish a Crime Prevention through Environmental Design (CPTED) survey before beginning alcohol service.
- b. All employees selling and/or serving beer and wine, or directly supervising such sales and/or service, shall comply with Municipal Code Section 9.84.030 (Responsible Beverage Service Training) and finish the Licensee Education on Alcohol and Drugs (LEAD) program, or another equivalent program offered or certified by the California Department of Alcoholic Beverage Control within 90 days of employment at the establishment. Employees who have finished the course within the last 12 months are exempt from this requirement.

23.312 LIVE/WORK

Sections:

- 23.312.010– Chapter Purpose
- 23.312.020– Applicability
- 23.312.030– Required Permits
- 23.312.040– Standards for Live/Work
- 23.312.050– Findings

23.312.010 – Chapter Purpose

This chapter establishes live/work standards that:

- A. Provide for the appropriate development of units which incorporate both living and working space;
- B. Provide flexibility as needed for the development of live/work units, particularly within existing buildings;
- C. Provide locations where appropriate new businesses can start up;
- D. Provide opportunities for people to live in mixed-use industrial and commercial areas where compatible with existing uses;
- E. Protect existing and potential industrial uses from conflicts with nearby residential uses;
- F. Protect existing and potential residential uses from conflicts with nearby industrial uses;
- G. Permit live/work units that function predominantly as workspaces and secondarily as residences;
- H. Ensure that the division of space between living and working space within these units reflects the priority of workspace; and
- I. Ensure that the exterior design of live/work buildings is compatible with the exterior design of commercial, industrial, and residential buildings in their area, while remaining consistent with the predominantly workspace character of live/work buildings.

23.312.020 – Applicability

This chapter applies to all live/work units in any district in Berkeley.

23.312.030 – Required Permits

- A. **General Requirement.** A permit is required for a live/work unit and/or for a business that makes up the work portion of the unit.
- B. **Residential Districts.** Live/work units are not permitted in all residential districts.
- C. **Commercial Districts.**
 - 1. **All Commercial Districts Except C-SA and C-W.** In all commercial districts except the C-SA and C-W districts, live/work units are allowed with a Zoning Certificate. Special circumstances that require a Use Permit are identified in Section 23.312.040 (Standards for Live/Work).
 - 2. **C-SA District.** A Use Permit is required for all live/work units in the C-SA district.
 - 3. **C-W District.**
 - a. An AUP is required for live/work units in the C-W district when:
 - i.* Nine or fewer live/work units are created; and
 - ii.* A dwelling unit is not changed into a live/work unit.
 - b. A Use Permit is required when the AUP requirements in Paragraph (a) above are not met.
- D. **Manufacturing Districts.**
 - 1. **M and MM Districts.** Live/work units are not permitted in the M and MM districts.
 - 2. **MU-LI District.**
 - a. An AUP is required for live/work units in the MU-LI district when:
 - i.* No new floor area is created; and
 - ii.* A dwelling unit is not changed into a live/work unit.
 - b. A Use Permit is required when the AUP requirements in Paragraph (a) above are not met.
 - 3. **MU-R District.**
 - a. An AUP is required for live/work units in the MU-R district when:
 - i.* The applicable requirements 23.206.090.D (Development Standards) and 23.322 (Parking and Loading) are satisfied;
 - ii.* Less than 5,000 square feet of gross floor area is added or changed;
 - iii.* Four or fewer live/work units are created; and
 - iv.* A dwelling unit is not changed into a live/work unit.

- b. A Use Permit is required when the AUP requirements in Paragraph (a) above are not met.

23.312.040 – Standards for Live/Work

A. **All Districts.** The following standards apply to live/work units in all districts.

1. **General Standards.**

- a. A cooking space and sanitary facility in conformance with applicable building standards adopted by the City is required.
- b. Adequate and clearly defined working space constituting no less than 50 percent of the gross floor area of the live/work unit is required.
 - i. The working space must be reserved for and regularly used by one or more live/work unit residents and be consistent with City administrative guidelines for live/work design.
 - ii. If the workspace is less than 60 percent (or less than 50 percent in units created by change of use from a dwelling unit), the unit is considered a dwelling unit and is subject to all requirements applicable to dwelling units.
- c. At least 40 square feet of usable open space shall be provided for each live/work unit.
- d. For live/work units established through change of use of an existing building, the Zoning Adjustments Board (ZAB) may approve a Use Permit to substitute interior space accessible to all residents for the required open space in the project, if it finds that it is not practical or desirable to provide exterior open space.

2. **Business License.** At least one resident in each live/work unit shall maintain at all times a valid City Business License and Zoning Certificate or Use Permit for a business on the premises.

3. **Employment, Client, and Customer Visits.**

- a. Except in the C-AC district, persons who do not live in the live/work unit may be employed in a live/work unit if an additional Use Permit is obtained and the required on-site parking space is provided.
- b. Client and customer visits to live/work units are permitted if an additional Use Permit is obtained and the required on-site parking is provided.
- c. In the C-AC district, clients, customers and employees are permitted at the site without a Use Permit.

4. **Unit Rental and Sale.** No portion of a live/work unit may be separately rented or sold as a commercial space for a person or persons not living on the premises, or as a residential space for a person or persons not working on the premises.
5. **Change of Use.**
 - a. To change a dwelling unit to a live/work unit, the findings required by Section 23.326.040 (Elimination of Dwelling Units and Accessory Dwelling Units through Conversion and Change of Use) must be made.
 - b. Establishing or changing the work use of a live/work unit to medical offices or group instruction requires ZAB approval of a Use Permit to subject to Section 23.312.050 (Findings) below.
 - c. In districts other than the MU-LI district, live/work units may be changed to exclusively residential use or the residential floor area increased above 40 percent, only if all requirements for establishing a residential use are met.
 - d. In districts other than the MU-R district, live/work units may be changed to an exclusively commercial use, provided that in the C-W district only ground floor space may be so changed. All such changes are subject to Section 23.326.040 (Elimination of Dwelling Units and Accessory Dwelling Units through Conversion and Change of Use).
6. **Low Income Inclusionary Units.** The following low income inclusionary standards apply to any project that creates five or more live/work units.
 - a. One inclusionary live/work unit shall be provided for each five live/work units in the project, notwithstanding a fraction of a unit.
 - b. Inclusionary live/work units shall be sold or rented at a price or rent affordable to a household with an income of 80 percent of the median income for the Oakland Primary Metropolitan Statistical Area.
 - c. Inclusionary units shall be affirmatively marketed by the developer of a project to income-eligible persons performing a work activity permitted in the district where the project is located whose type of work causes them to have a requirement for a space larger in size than typically found in residential units.
 - d. Inclusionary live/work units shall maintain affordable rents or resale prices in accordance with the standards in Chapter 23.328 (Inclusionary Housing).
 - e. At the applicant's sole discretion, inclusionary live/work units may:
 - i.* Have a lower grade of finishes than other units in the project.
 - ii.* Be located anywhere within the project.
 - iii.* Be smaller than other live/work units in the project as long as they meet the minimum size requirement for live/work units in the district.

B. **C-W District.** In addition to the standards in Subsection A (All Districts) above, the following live/work standards apply in the C-W district.

1. Only ground floor space may be changed to live/work units.
2. The total floor area of the live/work unit must be at least 800 square feet.

C. **MU-LI District.** In addition to the standards in Subsection A (All Districts) above, the following live/work standards apply in the MU-LI district.

1. At least one resident in the live/work unit must be engaged in an art craft studio activity or in an activity which requires space not typically available in a conventional residential setting.
2. The specific activity a live/work resident will engage in must be stated.
3. The total floor area of the live/work unit must be at least 1,000 square feet.

D. **MU-R District.** In addition to the standards in Subsection A (All Districts) above, the following live/work standards apply in the MU-R district.

1. The total floor area of the live/work unit must be at least 1,000 square feet.
2. The live/work unit must meet the location limitations in 23.206.090.B.8 (MU-R Mixed Use-Residential District - Residential Uses).

23.312.050 – Findings

A. **All Districts.**

1. To approve any Use Permit or AUP for a live/work unit in any district, the review authority must find that the proposed project is consistent with the purpose of this chapter.
2. To approve a Use Permit to establish or change the work use of a live/work unit to medical office or group instruction, the ZAB must find that adequate parking for the use has been provided.

B. **C-W District.** In addition to the findings in Subsection A (All Districts) above, the ZAB may approve a Use Permit to change a residential unit to a live/work unit and retain less than 75 percent of the pre-existing residential area as living area within the live/work unit only if it makes all of the following findings:

1. There are special circumstances particular to the application which make it appropriate to retain less than 75 percent of the pre-existing residential area as living space within the live/work unit; and
2. The exterior appearance of the live/work unit has been designed to be compatible with adjacent and nearby residential uses.

- C. **MU-LI District.** In addition to the findings in Subsection A (All Districts) above, the review authority may approve a Use Permit or AUP for a live/work unit in the MU-LI district only if it makes all of the following findings:
1. The applicant has made adequate provisions to ensure that within the live/work units, occupants of the live/work units will only engage in the occupations listed in the definition of art/craft studios.
 2. Development of such live/work units is not incompatible with adjacent and nearby industrial uses.
 3. The applicant has recorded with the County Recorder a statement acknowledging that the live/work unit is being established in a district where manufacturers and other industries operate lawfully and that the applicant will not seek to impede their lawful operation. In addition, the applicant will require any tenants to sign such a statement, and require all persons purchasing live/work units to sign and record such a statement.
- D. **MU-R District.** In addition to the findings listed in Subsection A (All Districts) above, the review authority may approve a Use Permit or AUP to establish or modify a live/work unit in the MU-R district only if it makes all of the following findings:
1. Establishment of a live/work unit will not interfere with the lawful operation of manufacturers and other industries existing in or adjacent to the district and will not impede the lawful future establishment of manufacturers and other industries permitted under the West Berkeley Plan.
 2. The applicant has recorded with the County Recorder a statement acknowledging that the live/work unit is being established in a district where manufacturers and other industries operate lawfully and that he/she will not seek to impede their lawful operation. In addition, the applicant will require any tenants to sign such a statement, and require all persons purchasing live/work units to sign and record such a statement.
 3. If the applicant proposes to change one or more dwelling unit to a live/work unit, the elimination of dwelling unit and the change of use would not be materially detrimental to the housing needs and public interest of the affected neighborhood and the city.
 4. If the applicant proposes to change a residential unit to a live/work unit and retain less than 75 percent of the pre-existing residential area as living area within the live/work unit:
 - a. There are special circumstances particular to the application which make it appropriate to retain less than 75 percent of the pre-existing residential area as living space within the live/work unit; and

- b. The exterior appearance of the live/work unit has been designed to be compatible with adjacent and nearby residential uses.

23.314 SHORT-TERM RENTALS

Sections:

- 23.314.010– Chapter Purpose
- 23.314.020– Definitions
- 23.314.030– Applicability
- 23.314.040– General Regulations
- 23.314.050– Operating Standards and Requirements
- 23.314.060– Violations and Remedies

23.314.010 – Chapter Purpose

This chapter establishes short-term rental standards that:

- A. Prevent long-term rental units from being replaced with short-term rentals and protect affordable housing units from conversion;
- B. Preserve and protect neighborhood character and livability from nuisances that are often associated with short-term rentals;
- C. Generate City revenue to share infrastructure cost and other public expenditures by operation of short-term rentals under established standards; and
- D. Provide alternative forms of lodging.

23.314.020 – Definitions

A. **Terms Defined.** Terms used in this chapter are defined as follows:

1. **Adjacent Properties.** The dwelling units abutting and confronting, as well as above and below, a dwelling unit within which a short-term rental is located.
2. **Host.** Any owner or tenant host. An owner host is a person who is the owner of record of residential real property, as documented by a deed or other such evidence of ownership, who offers their host residence, or a portion thereof, as a short-term rental. A tenant host is a lessee of residential real property, as documented by a lease or other such evidence, who offers their host residence, or portion thereof, as a short-term rental.
3. **Host Present or Host Presence.** The host is living in the host residence during the short-term rental period. In the case of a parcel comprised of a single primary unit and one or more authorized accessory dwelling units and/or accessory buildings, the host is considered present if he or she is present in any unit on such parcel.
4. **Hosting Platform.** A business or person that provides a means through which a host may offer a dwelling unit, or portion thereof, for short-term rentals. A hosting

platform is usually, though not necessarily, provided through an internet-based platform. It generally allows a property owner or tenant to advertise the dwelling unit through a website provided by the hosting platform and provides a means for potential short-term rental transients to arrange short-term rentals, whether the short-term rental transient pays rent directly to the host or to the hosting platform.

5. **Host Residence.** A host's principal place of residence, as defined by whether the host carries on basic living activities at the dwelling place and, whether such dwelling place is the host's usual place of return. Motor vehicle registration, driver's license, voter registration or other evidence as may be required by the City shall be indicia of principal residency.
6. **Local Contact.** A person designated by the host who shall be available during the term of any short-term rental for the purpose of
 - a. Responding within sixty minutes to complaints regarding the condition or operation of the dwelling unit or portion thereof used for Short-Term Rental, or the conduct of Short-Term Rental Transients; and
 - b. Taking appropriate remedial action on behalf of the Host, up to and including termination of the short-term rental, if allowed by and pursuant to the short-term rental agreement, to resolve such complaints.
7. **No Fault Eviction.** An eviction pursuant to the Ellis Act or Sections 13.76.130.A.9 or 10 of the Municipal Code.
8. **Short-Term Rental.** The use of any dwelling unit, authorized accessory dwelling unit or accessory building, or portions thereof for dwelling, sleeping or lodging purposes by short-term rental transients. Excludes tourist hotels and residential hotels.
9. **Short-Term Rental Transient or STR Transient.** Any person who rents a dwelling unit, authorized accessory dwelling unit or accessory building, or portion thereof, for less than 14 consecutive days.

B. **Terms Not Defined.** Terms not defined in this section shall be interpreted to give this chapter its most reasonable meaning and application, consistent with applicable state and federal law.

23.314.030 – Applicability

This chapter applies to the rental of a dwelling unit, accessory dwelling unit or accessory building for a period of less than 14 consecutive days.

23.314.040 – General Regulations

A. **Host Residence.** Short-term rentals are permitted only in the host residence.

- B. **BMR Units.** Short-term rentals are not permitted in below market rate (BMR) units. BMR units for short-term rental purposes refer to dwelling units whose rents are listed as a result of deed restrictions or agreements with public agencies, and whose tenants must be income qualified.
- C. **No-Fault Evictions.** A property containing a unit with a no-fault eviction may not operate a short-term rental for five years from the date of the eviction unless it is a single-family home that has been vacated for purposes of owner occupancy in compliance with the Rent Stabilization Ordinance in Municipal Code Chapter 13.76 (Rent Stabilization and Eviction for Good Cause Ordinance).
- D. **Accessory Buildings.**
 - 1. Short-term rentals are allowed in:
 - a. Accessory buildings; and
 - b. Accessory dwelling units permitted before April 3, 2017 unless the accessory dwelling unit is used for long-term rentals, as defined in Municipal Code Chapter 13.76 (Rent Stabilization and Eviction for Good Cause Ordinance) or has been used for long-term rentals at any time before April 3, 2017.
 - 2. A short-term rental is not allowed in an accessory dwelling unit permitted after April 3, 2017.

23.314.050 – Operating Standards and Requirements

A short-term rental must conform to all of the operating standards and requirements in this section.

A. Proof of Host Residency.

- 1. **Owner-Host.** An owner-host of a short-term rental must provide the Planning and Development Department documentation of owner-host and host residence status and, if applicable, host presence.
- 2. **Tenant-Host.** A tenant-host must provide the Planning and Development Department documentation of lessee status, host residence and host presence, if applicable. In addition, a tenant-host must present written authorization allowing for a short-term rental in the host residence from the building owner or authorized agent of the owner.

B. Allowed Duration and Required Residency Timeframes.

- 1. When the host is present, a short-term rental is allowed for an unlimited number of days during the calendar year.
- 2. When the host is not present, a unit may be used as a short-term rental for no more than 90 days per calendar year.

C. **Number of Occupants.** The maximum number of short-term rental transients allowed for a short-term rental unit is as provided in Municipal Code Chapter 19.40 (Uniform Housing Code).

D. **Notification.**

1. After the City approves a Zoning Certificate and Business License for a short-term rental, a host shall notify residents of all adjacent properties that a short-term rental has been established. Notification shall include host and local contact information.
2. A host shall notify residents of all adjacent properties of updated host, local contact, or other information within one week of changes to such information.

E. **Enforcement Fees.**

1. For the initial enforcement period, while enforcement costs are being determined, the host shall pay an additional enforcement fee in an amount equal to 2 percent of the rents charged by that host, not to exceed the cost of the regulatory program established by this chapter over time.
2. Enforcement fees may be paid by the hosting platform on behalf of the host. After the initial enforcement period, the City Council may revise the enforcement fee by resolution.

F. **Liability Insurance.** Liability insurance is required of the host, or hosting platform on behalf of the host, in the amount of at least \$1 million.

G. **Documents Provided to Short-Term Rental Transients.** The host or hosting platform must provide to short-term rental transients upon booking and arrival electronic or paper copies of:

1. The Community Noise Ordinance in Municipal Code Chapter 13.40 (Community Noise); and
2. The Smoke-Free Multi-Unit Housing Ordinance in Municipal Code Chapter 12.70 (Smoking Pollution Control).

H. **Transient Occupancy Tax.** Either the host or hosting platform must pay the transient occupancy tax.

I. **Housing Code Compliance.** Any building or portion of a building used for short-term rentals shall comply with Municipal Code Section 19.40 (Uniform Housing Code).

J. **Payment of Taxes.** The host shall pay all City taxes and fees owed in a timely manner.

K. **Host Responsibilities.**

1. The host shall list on any rental advertisement the Zoning Certificate number.
2. Upon request, the host must provide both the Business License number, if required by Municipal Code Chapter 9.04 (Business Licenses), and Zoning Certificate for the short-term rental to the City and/or a vendor hired by the City to administer this chapter.

23.314.060 – Violations and Remedies

- A. **Compliance with Second-Response Ordinance.** The host shall comply with the Second Response Ordinance in Municipal Code Section 13.48 (Civil Penalties for Multiple Responses to Loud or Unruly Parties, Gatherings or Other Similar Events). The host is prohibited from operating short-term rentals for one year after issuance of a third violation affidavit.
- B. **Violations and Remedies of this Chapter.**
 1. Violation of this chapter is punishable as set forth in Municipal Code Sections 1.20 (General Penalty) and 1.28 (Administrative Citations).
 2. Violation of this chapter is a public nuisance subject to abatement under Municipal Code Sections 1.24 (Abatement of Nuisances), 1.26 (Violations Declared Public Nuisance), and 23.414 (Nuisance Abatement).
 3. In any enforcement action, the prevailing party is entitled to recover reasonable attorneys' fees and costs; provided that, pursuant to Government Code Section 38773.5, attorneys' fees are only available in an action or proceeding in which the City has elected, at the beginning of such action or proceeding, to seek recovery of its own attorneys' fees. An award of attorneys' fees to a prevailing party may not exceed the amount of reasonable attorneys' fees incurred by the City in the action or proceeding.
 4. Any Berkeley resident may bring a private action for injunctive relief to prevent or remedy a public nuisance. No action may be brought under this subsection unless and until the prospective plaintiff has given the City and the prospective defendant(s) at least 30 days written notice of the alleged public nuisance and the City has failed to initiate proceedings within that period, or after initiation, has failed to diligently prosecute.
 5. The following constitute a public nuisance:
 - a. Any occurrence at a short-term rental unit that creates a substantial disturbance of the quiet enjoyment of private or public property in a significant segment of a neighborhood, such as excessive noise or traffic, obstruction of public streets by crowds or vehicles, public intoxication, the service to or consumption of alcohol by minors, fights, disturbances of the peace, litter or other similar conditions.

- b. Any short-term rental transient of a short-term rental unit where an event is taking place refusing access to, or interfering with access by, Fire Department or other City personnel responding to an emergency call or investigating a situation.
6. Notwithstanding any provision of Municipal Code Chapter 13.48 (Civil Penalties for Multiple Responses to Loud or Unruly Parties, Gatherings or Other Similar Events) to the contrary, a public nuisance as defined in this section is subject to remedies in this subsection.

23.316 PERCENTAGE FOR PUBLIC ART ON PRIVATE PROJECTS

Sections:

- 23.316.010– Chapter Purpose
- 23.316.020– Applicability
- 23.316.030– Definitions
- 23.316.040– General Requirements
- 23.316.050– Required Permits
- 23.316.060– In-Lieu Fees
- 23.316.070– Administrative Regulations (Guidelines)

23.316.010 – Chapter Purpose

The purpose of this chapter is to establish a public art requirement for private developments to provide the following benefits to the community:

- A. Maintain Berkeley’s art and culture for generations.
- B. Recognize the vital importance of the arts to the city as a whole.
- C. Enhance the economic sustainability of artists and arts organizations as a key to the vitality of the city.
- D. Make a lasting contribution to the intellectual, emotional and creative life of the community at large, and to create a more desirable community to live, work, and recreate.

23.316.020 – Applicability

- A. **Districts.** This chapter applies in all districts in Berkeley.
- B. **Uses.** This chapter applies to:
 - 1. New multifamily residential projects of five or more dwelling units;
 - 2. New commercial structures; and
 - 3. New industrial structures
- C. **Project Size.** This chapter applies to all construction of building additions exceeding 10,000 square feet.
- D. **Exceptions.** This chapter does not apply to the following project types:
 - 1. Multifamily housing that has a regulatory agreement with a government agency restricting the rent and limiting tenancy to qualifying households not exceeding specified incomes for at least 60 percent of the units.
 - 2. Buildings with religious assembly uses as defined in Chapter 23.502 (Glossary) and buildings with arts and cultural uses. For purposes of this section, "arts and

cultural use" means buildings that have as their primary purpose the presentation of one or more cultural resources, and that are operated by public entities or nonprofit organizations dedicated to cultural activities available to a broad public.

3. Transitional housing.

23.316.030 – Definitions

A. **Terms Defined.** Terms used in this chapter are defined as follows:

1. **Artist.** An individual independent professional practitioner of the visual, performing, or literary arts, as judged by educational qualifications, a history of creating a body of public or publicly-displayed artwork, critical recognition in publications or online, a record of exhibitions and/or artwork sales. Members of the design team are not artists for on-site publicly accessible art projects. Individuals who have a conflict of interest, including a familial or financial relationship to the developer or design team, are not artists for on-site publicly accessible art projects.
2. **Construction Cost.** The amount determined by the Chief Building Official for purposes of setting the building permit fee in accordance with the most recent building valuation date specified in the building permit fees section of the resolution establishing fees and charges as adopted by the City Council.
3. **Developer.** A person or entity that is financially and legally responsible for the planning, development and construction, or maintenance and operation of any project subject to this chapter.
4. **On-Site Publicly Accessible Art.** An original work by an artist, including, but not limited to, functional art integrated into the building, landscape, or element of infrastructure, including sculpture, monument, mural, painting, drawing, photography, fountain, banner, mosaic, textile, art glass, digital media art, video, earthworks and multi-media installation, that is in a location that is accessible to and available for use by the general public during normal hours of business operation consistent with the operation and use of the premises.
5. **Guidelines.** The guidelines adopted by the City Council pursuant to Section 23.316.070 (Administrative Regulations (Guidelines)).

B. **Terms Not Defined.** Terms not defined in this section shall be interpreted to give this chapter its most reasonable meaning and application, consistent with applicable state and federal law.

23.316.040 – General Requirements

Developers subject to this chapter shall do one of the following:

- A. Include on-site publicly accessible art valued at 1.75 percent of the construction cost. If the value of on-site publicly accessible art as installed is less than 1.75 percent of the construction cost, an amount equal to 80 percent of the difference in value shall be paid to the City as an in-lieu fee.
- B. Pay an in-lieu fee top the City of 0.80 percent of the construction cost.

23.316.050 – Required Permits

- A. **Subject to Laws and Regulations.** On-site publicly accessible art is subject to, and shall comply with, all applicable City ordinances and laws and regulations of other governmental agencies.
- B. **Permits Must Be Obtained.**
 - 1. Before construction, the applicant shall identify and secure all applicable permits from the Building and Safety Division, Public Works Department and other affected City divisions and departments.
 - 2. The process for identifying and securing required permits shall be set forth in the Guidelines.

23.316.060 – In-Lieu Fees

- A. **Alternative to On-Site Art.** As an alternative to providing on-site publicly accessible art, the developer may elect to pay an in-lieu fee to the City as set forth in this section.
- B. **Use of Fees.** Any in-lieu fees paid to the City pursuant to this chapter shall be used for art and cultural services as set forth in the Guidelines.
- C. **Amount of Fee.** The in-lieu fee shall be 0.80 percent of the construction cost.
- D. **Time of Payment.** The in-lieu fee shall be paid at the same time as other building permit fees.

23.316.070 – Administrative Regulations (Guidelines)

- A. **Adoption of Guidelines.** The Civic Arts Commission shall recommend and the Council, by resolution, shall adopt guidelines for the administration and implementation of this chapter.
- B. **Determining Compliance with Guidelines.** The Civic Arts Commission shall be responsible for determining if On-Site Publicly Accessible Art complies with the Guidelines.

23.318 URBAN AGRICULTURE

Sections:

- 23.318.010– Chapter Purpose
- 23.318.020– Applicability
- 23.318.030– Urban Agriculture Uses and Levels of Discretion
- 23.318.040– Thresholds
- 23.318.050– Operation Standards
- 23.318.060– Complaints

23.318.010 – Chapter Purpose

This chapter establishes urban agriculture standards to provide the following community benefits:

- A. Support the local economy and increase access to fresh local produce.
- B. Strengthen the health and social fabric of communities by encouraging and supporting community gardens.
- C. Accomplish the Berkeley Climate Action Plan goal of supporting efforts to build more complete and sustainable local food production and distribution systems.

23.318.020 – Applicability

These regulations supersede definitions of incidental or ancillary uses.

23.318.030 – Urban Agriculture Uses and Levels of Discretion

- A. **Zoning Certificate.** When all of the thresholds in Section 23.318.040 (Thresholds) are met, the use is considered Low-Impact Urban Agriculture (LIUA) and is allowed by right with a Zoning Certificate.
- B. **Administrative Use Permit.** When one or more of the thresholds in Section 23.318.040 (Thresholds) are not met, the use is considered High-Impact Urban Agriculture (HIUA) requires an AUP.

23.318.040 – Thresholds

The levels of discretion for urban agriculture are based on the following thresholds:

- A. Maximum parcel size of 7,500 square feet.
- B. Maximum lot coverage of 20 percent for accessory structures and buildings.
- C. Maximum group classes and workshops of 20 participants per class conducted no more than three times per week.

- D. Hours of operation from 8:00 a.m. to 8:00 p.m., including but not limited to activities related to gardening and planting of horticultural crops, group classes, and sales.
- E. Use of organic pesticides.

23.318.050 – Operation Standards

- A. **Performance Standards.** The growing, production, or sale of urban agricultural products may not involve hazardous materials or processes or create offensive or objectionable noise, vibration, odors, heat, dirt, or electrical disturbance perceptible by a person beyond the lot line of the subject lot.
- B. **Sales and Donations.**
 - 1. Sales and/or donations of urban agricultural products grown and produced on-site are permitted.
 - 2. If selling or donating urban agricultural products to the public, the urban agriculture use shall comply with all applicable food safety laws, including the California Health and Safety Code.
- C. **Garbage and Compost.**
 - 1. Garbage and compost receptacles must be screened from the street and adjacent properties by utilizing landscaping, fencing, or storage structures and all garbage shall be removed from the site weekly.
 - 2. Compost piles and containers must be set back at least 10 feet from residential buildings when an urban agriculture use abuts a residential use.
- D. **Farm Equipment.** Use of mechanized farm equipment is not permitted in Residential Districts and when the urban agriculture use abuts a residential use, with the following exceptions:
 - 1. Heavy equipment may be used initially to prepare the land for agriculture use.
 - 2. Landscaping equipment designed for household use is permitted.
 - 3. Equipment when not in use must be enclosed or otherwise screened from sight.

23.318.060 – Complaints

Uses, activities, or events associated with urban agriculture are subject to Municipal Code Chapters 23.414(Nuisance Abatement) and 12.92 (Anti-Blight) if found to be non-compliant with this chapter.

23.320 CANNABIS USES

Sections:

23.320.010– Chapter Purpose

23.320.020– Cannabis Retail

23.320.030– Commercial Cannabis Cultivation

23.320.040– Cannabis Manufacturers, Testing Labs, and Distributors

23.320.050– Microbusinesses

23.320.010 – Chapter Purpose

This chapter establishes standards for cannabis uses that supplement the regulations in Municipal Code Chapter 12.21 (Cannabis Business: General Regulations) and Chapter 12.22 (Cannabis Business Operating Standards).

23.320.020 – Cannabis Retail

A. **Definitions.** The terms cannabis retailer, storefront retailer, delivery-only retailer, A-Retailer, and M-Retailer are defined in Municipal Code Section 12.21.020 (Definitions).

B. Non-Conforming M-Retailers.

1. A medical cannabis dispensary (M-Retailer) existing and authorized as of January 1, 2010 that does not comply with this section may continue at its current medical cannabis dispensing location as a legal nonconforming use.
2. Notwithstanding Chapter 23.324 (Nonconforming Uses and Structures) or the regulations in this section, the Zoning Officer may approve an AUP to allow the expansion of a lawful nonconforming medical cannabis dispensary onto an adjacent parcel.

C. Location Changes.

1. A cannabis retailer in good standing with state and City regulations, including obtaining all necessary licenses and full payment of all fees and with no outstanding violations, may seek approval for a change in location.
2. An application for a change of location shall be evaluated based on the requirements to operate a cannabis business effective at the time of the proposed change.

D. Storefront Retailers.

1. A storefront retailer is permitted in Commercial Districts with a Zoning Certificate, and must maintain compliance with Municipal Code Chapters 12.21 (Cannabis Business: General Regulations) and 12.22 (Cannabis Business Operating Standards) and security regulations promulgated by the Chief of Police.

2. A storefront retailer shall be approved through the selection process described in Municipal Code Section 12.22.020 (Selection Process).
3. Up to seven storefront retail permits may be issued, one of which is reserved for an equity candidate as defined in Municipal Code Section 12.21.020 (Selection Process). This limit to the number of storefront retailers shall not be reconsidered for a period of three years from March 15, 2020.
4. Expansion of an approved storefront retailer must comply with the development standards for the zoning district in which it is located.
5. Storefront retailers may operate as a retail storefront microbusiness as defined in Municipal Code Chapter 12.21 (Cannabis Business: General Regulations) subject to obtaining all required state and local licenses.
6. **Buffers.**
 - a. A storefront retailer may not be located:
 - i. Within 600 feet of another storefront retailer, a public or private elementary school, or a City-operated community center or skate park; or
 - ii. Within 1,000 feet of a public or private middle school or high school.
 - b. Notwithstanding Paragraph (a) above, a seventh storefront retailer, to be operated by an equity business, may not be located within 600 feet of another storefront retailer or school.

E. Delivery-Only Retailers.

1. Seven delivery-only retailers are permitted citywide, four of which shall be operated by an equity business, and three of which shall be a non-equity business.
2. A delivery-only retailer shall be approved through the selection process described in Municipal Code Section 12.22.020 (Selection Process).
3. Delivery-only retailers are permitted with a Zoning Certificate in all Commercial Districts other than the C-N district.
4. Delivery-only retailers are permitted in the Manufacturing (M) district, shall be evaluated and regulated for zoning purposes in the same way as a warehouse-based non-store retailer, and shall be subject to the numeric and buffer requirements in this section for delivery-only retailers.
5. A delivery-only retailer may not be located within 300 feet of any school or City-operated community center or skate park.
6. A delivery-only retailer may not be located in a street-fronting tenant space in a Commercial District.

F. Lounges.

1. A Lounge, as defined in Municipal Code Section 12.21.020 (Definitions), may be permitted at an approved retailer with a Use Permit.
2. A Lounge must comply with the operational standards established by the City of Berkeley Department of Health, Housing and Community Services.

23.320.030 – Commercial Cannabis Cultivation

A. Definition. The term “commercial cannabis cultivation” as used in this chapter is defined in Municipal Code Chapter 12.21 (Cannabis Businesses: General Regulations).

B. General Requirements.

1. Commercial cannabis cultivation shall comply with Municipal Code Chapter 12.22 (Cannabis Business Operating Standards), security measured required by the Chief of Police, and the requirements of this chapter.
2. Commercial cannabis cultivation may include testing, processing, manufacturing, and food preparation only to the extent expressly permitted by MAUCRSA.

C. Where Allowed. Commercial cannabis cultivation is permitted with a Zoning Certificate in the Manufacturing (M) district, subject to the following limitations:

1. Commercial cannabis cultivation shall only occur at licensed cannabis businesses.
2. Cannabis may not be dispensed and client, patient or member services and retail sales are not permitted at cannabis cultivation facilities.

D. Maximum Canopy Area.

1. The total citywide canopy area of cannabis cultivation facilities may not exceed 180,000 square feet.
2. The total citywide canopy area of all minor cannabis cultivation facilities may not exceed 48,000 square feet plus any area not used by a major cannabis cultivation facility.

E. Different Licenses. Separate spaces used by different licensees may be aggregated at the same location.

F. Outdoor Cultivation Prohibited. Commercial cannabis cultivation is not permitted outside of a building.

G. Cannabis Nurseries. A cannabis nursery as defined in Municipal Code Section 21.21.020 (Definitions) is subject to the same regulations as a commercial cannabis cultivation cannabis cultivation facility.

H. **Buffer.** A commercial cannabis cultivation facility may not be located within 300 feet of a school or City-operated community center or skate park.

I. **Major Cannabis Cultivation Facilities.**

1. No more than six major cannabis cultivation facilities are permitted.
2. A major cannabis cultivation facility may not be approved until the City Council adopts licensing process and standards for such uses.
3. Adopted standards shall require indoor cultivation uses to offset the net increased energy used as compared to a regular industrial facility.
4. Adopted standards also may include whether:
 - a. Cannabis cultivation uses will provide a percentage of all usable product cultivated at no cost to very low-income patients;
 - b. Cannabis cultivation uses will use organic methods in cultivation and processing to the maximum extent reasonable; and
 - c. The form of organization, ownership, and practices of cannabis cultivation uses ensure equity and accountability, low prices, and an adequate supply of high-quality cannabis to customers.

23.320.040 – Cannabis Manufacturers, Testing Labs, and Distributors

A. **Equivalent Uses.** Cannabis manufacturers, testing labs, and distributors shall be evaluated and regulated in the same way as the equivalent non-cannabis uses shown in Table 23.320-1.

TABLE 23.320-1: EQUIVALENT NON-CANNABIS USES

| CANNABIS USE | EQUIVALENT NON-CANNABIS USE |
|---|------------------------------------|
| Manufacturing, processing, food preparation | Light Manufacturing |
| Testing labs | Testing labs |
| Distribution | Wholesale Trade |

B. **Buffer.** Cannabis manufacturers, testing labs and distributors may not be located within 300 feet of a school.

23.320.050 – Microbusinesses

- A. **Definition.** The term “microbusiness” as used in this chapter is defined in Municipal Code Chapter 12.21 (Cannabis Business: General Regulations).
- B. **General.** A microbusiness is subject to the development standards in this chapter for each use on the premises, with the following exceptions:
 - 1. In cases where the development standards and permit thresholds for two or more uses are different, the more restrictive standards apply.
 - 2. Retail nursery microbusinesses are subject to 23.320.050.C (Retail Nursery Microbusinesses).
- C. **Retail Nursery Microbusinesses.**
 - 1. A used in this section, “existing nursery” means a legally established plant nursery in Berkeley established as of March 15, 2020.
 - 2. Up to two existing nurseries may convert to a retail nursery microbusiness. Retail nursery microbusinesses are not subject to the numeric or canopy limitations of other retailers or cannabis cultivators.
 - 3. In a Commercial or Manufacturing District, an existing nursery may convert to a retail nursery microbusiness by right with a Zoning Certificate if each use conducted on the premises complies with the applicable development standards in the Zoning Ordinance.
 - 4. In a Residential District, an existing nursery may convert to a retail nursery microbusiness with a Use Permit for a substantial expansion or change in character to a non-conforming use as provided in Chapter 23.324 (Nonconforming Uses, Structures, and Buildings).
 - 5. The City shall issue the Zoning Certificates and/or Use Permits to existing nurseries on a first-come, first-served basis.
 - 6. The City shall determine the right to retain the allocated Zoning Certificates and/or Use Permits as follows:
 - a. For a Zoning Certificate, the date of issuance of a concurrent business license and establishing and continuously operating the business.
 - b. For a Use Permit is required, the date the Use Permit application is deemed complete so long as the Use Permit is implemented with a business license within 30 days of approval and establishing and continuously operating the business.
 - 7. The 600-foot buffer required between cannabis retailers in 23.320.020 (Cannabis Retail) does not apply between a storefront cannabis retailers and a retail nursery microbusiness.

23.322 PARKING AND LOADING

Sections:

- 23.322.010– Chapter Purpose
- 23.322.020– Applicability
- 23.322.030– Required Parking Spaces
- 23.322.040– General Requirements
- 23.322.050– Parking Reductions
- 23.322.060– C-DMU Parking and Transportation Demand Management
- 23.322.070– Off-Street Parking Maximums for Residential Development
- 23.322.080– Parking Layout and Design
- 23.322.090– Bicycle Parking
- 23.322.100– On-site Loading Spaces
- 23.322.110– Parking Lots in Residential Districts
- 23.322.120– Transportation Services Fee

23.322.010 – Chapter Purpose

This chapter establishes parking and loading standards to:

- A. To efficiently allocate parking spaces in the City;
- B. Regulate the provision of off-street parking spaces within the City; and
- C. Reduce the amount of on-street parking of vehicles, thus increasing the safety and capacity of Berkeley’s street system.

23.322.020 – Applicability

- A. **New Uses and Buildings.** In all districts, off-street parking and loading as required by this chapter shall be provided when:
 - 1. A new building is constructed or moved onto a lot; and
 - 2. A new use is established where no use previously existed.
- B. **Enlargement and Intensification.**
 - 1. Where an existing use or structure is enlarged or intensified, but where there is no change in use, additional off-street parking and loading is required to serve only the enlarged or intensified area. Additional parking is not required to remedy parking deficiencies existing before the expansion or enlargement.
 - 2. As used in this section, enlarging or intensifying a use or structure includes, but is not limited to adding or creating floor area, dwelling units, guest rooms, seats, or employees.
- C. **Changes of Use.**

1. **Commercial Districts.** In the Commercial Districts, off-street parking is required for a change in use only when the structure is expanded to include new floor area.
2. **Manufacturing and R-SMU Districts.**
 - a. In the Manufacturing and R-SMU districts, off-street parking is required for a change in use only when:
 - i. The structure is expanded to include new floor area; and/or
 - ii. The use is changed to one with a numerical parking standard greater than the district minimum.
 - b. If the new use is changed to one with a higher numerical parking standard than the district minimum, the new use must provide the incremental difference between the two numerical parking standards. A higher numerical parking standard may be reduced to the district minimum as provided in Section 23.322.050.A.2 (Change of Use).
 - c. As used in this section, the “district minimum” parking requirement is:
 - i. 2 spaces per 1,000 square feet of floor area in the Manufacturing Districts; and
 - ii. 1 space per 1,000 square feet of floor area in the R-SMU district.
3. **All Other Residential Districts.** In all Residential Districts except for R-SMU, off-street parking spaces are required for all changes in use.

23.322.030 – Required Parking Spaces

A. Residential Districts.

1. **Spaces Required.** Table 23.322-1 shows minimum required off-street parking spaces in the Residential Districts.

TABLE 23.322-1: REQUIRED OFF-STREET PARKING IN RESIDENTIAL DISTRICTS

| Land Use | Number of Required Off-street Parking Spaces |
|--|--|
| Residential Uses | |
| Accessory Dwelling Unit | See Chapter 23.306 |
| Dwellings, including Group Living Accommodations | <u>R-3, R-4, and R-5 Districts (1-9 units):</u> If located on a roadway less than 26 feet in width in the Hillside Overlay: 1 per unit. <u>R-3, R-4, and R-5 District (10 or more units):</u> If located on a roadway less than 26 feet in width in the Hillside Overlay: 1 per 1,000 sq ft of gross floor area |

| Land Use | Number of Required Off-street Parking Spaces |
|---|--|
| | <u>All Other Districts</u> : If located on a roadway less than 26 feet in width in the Hillside Overlay: 1 per unit All Other Locations: None required |
| Dormitories, Fraternity and Sorority Houses, Rooming & Boarding Houses, Senior Congregate Housing | If located on a roadway less than 26 feet in width in the Hillside Overlay: 1 per each 5 residents, plus 1 for manager. All Other Locations: None required. |
| Rental of Rooms | If located on a roadway less than 26 feet in width in the Hillside Overlay: 1 per each two roomers All Other Locations: None required |
| Non-Residential Uses | |
| All non-residential uses except uses listed below | <u>R-SMU District</u> : 1 per 1,000 sq. ft. <u>All Other Residential Districts</u> : See 23.322.030.A.2 |
| Community Care Facility | One per two non-resident employees |
| Food Service Establishment | 1 per 300 sq. ft. |
| Hospital | <u>R-SMU District</u> : 1 per 1,000 sq. ft. <u>All Other Residential Districts</u> : 1 per each 4 beds plus 1 per each 3 employees |
| Library | 1 per 500 sq. ft. of publicly accessible floor area |
| Nursing Home | 1 per 3 employees |
| Medical Practitioners | 1 per 300 sq. ft. |
| Non-Medical Offices | <u>R-SMU District</u> : 1 per 1,000 sq. ft. <u>All Other Residential Districts</u> : 1 per 400 sq. ft. |
| Hotels, Tourist | 1 per 3 guest/sleeping rooms or suites plus 1 per 3 employees |

Notes:

[1] Excludes community care facilities which under state law must be treated in the same manner as a single-family residence.

2. **Other Uses.** If a use requires an AUP or Use Permit and is not listed in Table 23.322-1, the review authority shall determine the required number of off-street

parking spaces based on the amount of traffic generated by the use and the number of spaces required for other similar uses.

3. Offices.

- a. In Residential Districts where offices are allowed, the Zoning Adjustments Board (ZAB) may reduce the parking requirement for non-medical offices to one parking space per 800 square feet of gross floor area.
- b. To approve the reduction, the ZAB must find that the reduction is justified because the amount of direct contact with clients, visitors, or the general public will be less than ordinarily is the case.

4. ES-R Parking Requirement.

- a. For purposes of calculating required parking in the ES-R district, “bedroom” means any habitable space in a dwelling unit or residential accessory structure other than a kitchen or living room that is intended for or capable of being used for sleeping and that is at least 70 square feet in area.
- b. A room identified as a den, library, study, loft, dining room, or other extra room that satisfies this definition is considered a bedroom.
- c. Bathrooms, toilet rooms, closets, halls, storage or utility spaces and similar areas are not considered habitable spaces.
- d. The division of existing habitable space does not require additional parking if there is no net increase in the gross floor area of the building and no more than one additional bedroom is created.

B. Commercial Districts.

- 1. **Spaces Required.** Table 23.322-2 shows minimum required off-street parking spaces in the Commercial Districts, excluding the C-T district.

TABLE 23.322-2: REQUIRED OFF-STREET PARKING REQUIREMENTS IN COMMERCIAL DISTRICTS (EXCLUDING C-T)

| Land Use | Required Parking Spaces |
|--|--|
| Residential Uses | |
| Accessory Dwelling Unit | See Chapter 23.306 |
| Dwellings, including Group Living Accommodations | If located on a roadway less than 26 feet in width in the Hillside Overlay: 1 per unit All Other Locations: None required |
| Hotel, Residential | None required |
| Mixed-Use Residential | None required |

| Land Use | Required Parking Spaces |
|---|---|
| (residential use only) | |
| Senior Congregate Housing | None required |
| Non-Residential Uses | |
| All non-residential uses except uses listed below | C-DMU District: 1.5 per 1,000 sq. ft. All Other Commercial Districts: 2 per 1,000 sq. ft. |
| Hospital | 1 per each 4 beds plus 1 per each 3 employees |
| Library | C-DMU District: 1.5 per 1,000 sq. ft. All Other Commercial Districts: 1 per 500 sq. ft. of publicly accessible floor area |
| Nursing Home | 1 per 3 employees |
| Medical Practitioners | C-DMU District: 1.5 per 1,000 sq. ft. All Other Commercial Districts: 1 per 300 sq. ft. |
| Hotels, Tourist | C-DMU District: 1 per 3 guest/sleeping rooms or suites C-C, C-U, C-W Districts: 1 per 3 guest/sleeping rooms or suites plus 1 per 3 employees All Other Commercial Districts: 2 per 1,000 sq. ft. |
| Motels, Tourist | C-DMU District: 1 per 3 guest/sleeping rooms or suites C-C, C-U, C-W Districts: 1 per guest/sleeping room plus 1 for owner or manager [1] All Other Commercial Districts: 2 per 1,000 sq. ft. |
| Large Vehicle Sales and Rental | C-DMU District: 1.5 per 1,000 sq. ft. C-SA District: 1 per 1,000 sq. ft. All Other Commercial Districts: 2 per 1,000 sq. ft. |
| Small Vehicle Sales and Service | C-DMU District: 1.5 per 1,000 sq. ft. C-SA District: 1 per 1,000 sq. ft. All Other Commercial Districts: 2 per 1,000 sq. ft. |
| Manufacturing | C-DMU District: 1.5 per 1,000 sq. ft. C-W District: 1 per 1,000 sq. ft [1] All Other Commercial Districts: 2 per 1,000 sq. ft. |
| Wholesale Trade | C-DMU District: 1.5 per 1,000 sq. ft. C-W District: 1 per 1,000 sq. ft All Other Commercial Districts: 2 per 1,000 sq. ft. |
| Live/Work | If workers/clients are permitted in work area, 1 per first |

| Land Use | Required Parking Spaces |
|---|---|
| | 1,000 sq. ft. of work area and 1 per each additional 750 sq. ft. of work area |
| <u>Notes:</u> [1] Spaces must be on the same lot as building it serves | |

2. **Exemptions.** Table 23.322-3 shows projects and land uses in the Commercial Districts that are exempt from parking requirements. No Use Permit or other discretionary approval is required for these exemptions.

TABLE 23.322-3: PARKING EXEMPTIONS IN COMMERCIAL DISTRICTS

| District | Projects/Uses Exempt from Parking Requirement |
|----------|--|
| C-SA | First 1,000 square feet of new gross floor area in a development project |
| C-E | Commercial uses with less than 6,000 square feet of gross floor area |
| C-DMU | Additions up to 1,000 square feet of gross floor area or up to 25% of existing gross floor area, whichever is less |

3. **C-T District.**

- a. Off-street parking is not required in the C-T district.
- b. New off-street parking is not permitted on lots abutting Telegraph Avenue exclusively. New off-street parking is only permitted on lots abutting a street other than Telegraph Avenue where access to the parking is from curb cuts existing on July 6, 1989. A Use Permit is required to establish the new parking. To approve the Use Permit, the ZAB must find that traffic from the new parking will not significantly impede pedestrian circulation.

4. **C-W District.**

- a. **Required Parking Determined by Zoning Officer or ZAB.** For the following categories of uses as shown in Table 23.204-1 (Allowed Uses in Commercial Districts), the Zoning Officer or ZAB shall determine the number of required off-street parking spaces in the C-W district based on the amount of traffic generated by the use and the number of spaces required for other similar uses:
 - i. Public and quasi-public uses.
 - ii. Automobile and other vehicle oriented uses.

- iii. Outdoor uses.
 - iv. Residential and related uses.
 - v. Other miscellaneous uses.
 - vi. Other industrial uses.
- b. **Maximum Parking.** The number of parking spaces provided for new commercial floor area in the C-W district shall not exceed:
- i. 5 spaces per 1,000 square feet of gross floor area of food service uses; and
 - ii. 4 spaces per 1,000 square feet of gross floor area for all other commercial uses.

C. Manufacturing Districts.

- 1. **Spaces Required.**
- 2. Table 23.322-4 shows minimum required off-street parking spaces in the Manufacturing Districts.

TABLE 23.322-4: REQUIRED OFF-STREET PARKING IN MANUFACTURING DISTRICTS

| Land Use | Required Parking Spaces |
|---|--------------------------------|
| Residential Uses | |
| Accessory Dwelling Unit | See Chapter 23.306 |
| Dwellings | None required |
| Group Living Accommodation | None required |
| Non-Residential Uses | |
| All non-residential uses except uses listed below | 2 per 1,000 sq. ft. |
| Art/Craft Studio | 1 per 1,000 sq. ft. |
| Community Care Facility | 1 per 2 non-resident employees |
| Food Service Establishment | 1 per 300 sq. ft. |

| Land Use | Required Parking Spaces |
|---|---|
| Library | 1 per 500 sq. ft. of publicly accessible floor area |
| Laboratories | 1 per 650 sq. ft. |
| Nursing Home | 1 per 5 residents, plus 1 per 3 employees |
| Medical Practitioners | One per 300 sq. ft. |
| Large Vehicle Sales and Rental | MU-LI District: 1.5 per 1,000 sq. ft. All Other Districts: 1 per 1,000 sq. ft. of display floor area plus 1 per 500 sq. ft. of other floor area; 2 per service bay |
| Manufacturing | MU-R District: 1.5 per 1,000 sq. ft. All Other Districts: 1 per 1,000 sq. ft. for spaces less than 10,000 sq. ft.; 1 per 1,500 sq. ft. for spaces 10,000 sq. ft. or more |
| Storage, warehousing, and wholesale trade | 1 per 1,000 sq. ft. for spaces of less than 10,000 sq. ft.; 1 per 1,500 sq. ft. for spaces 10,000 sq. ft. or more |
| Live/Work | MU-LI District: 1 per 1,000 sq. ft. of work area where workers/clients are permitted MU-R District: if workers/clients are permitted in work area, 1 per first 1,000 sq. ft. of work area and 1 per each additional 750 sq. ft. of work area |
| <u>Notes:</u> [1] For multiple dwellings where the occupancy will be exclusively for persons over the age of 62, the number of required off-street parking spaces may be reduced to 25% of what would otherwise be required for multiple-family dwelling use, subject to obtaining a Use Permit. | |

3. Required Parking Determined by Zoning Officer or ZAB.

- a. For the following categories of uses as shown in Table 23-206.020-1, the Zoning Officer or ZAB shall determine the number of required off-street parking spaces in the Manufacturing Districts based on the amount of traffic generated by the use and the number of spaces required for other similar uses:
 - i.* Public and Quasi-Public Uses.
 - ii.* Vehicle Sales and Service Uses.
 - iii.* Other Miscellaneous Uses.
 - iv.* Industrial and Heavy Commercial Uses, excluding manufacturing and wholesale trade.

D. Calculating Required Spaces.

1. **Fractional Spaces.** When calculating the number of required off-street parking spaces results in a fractional space, any fraction below one-half is disregarded, and fractions one-half and above are counted as requiring one parking space.
2. **Employees.** Where a parking requirement is based on the number of employees, the number of employees is based upon the shift or employment period when the greatest number of employees are present.
3. **Floor Area.**
 - a. Where a parking requirement is based on floor area, the definition of gross floor area as set forth in 23.502 (Glossary) shall apply.
 - b. In Non-Residential Districts, the floor area calculation for the purpose of determining required parking shall also include outdoor dining areas, garden/building supply yards, customer-serving outdoor areas for retail sales, and other unenclosed areas of the lot.

E. **Additional Required Parking.** If the expected demand for off-street parking spaces is found to exceed the number of spaces required by Table 23.322-1, Table 23.322-2, or

F. Table 23.322-4, additional off-street parking may be required as a condition of approval.

G. **Buildings with Multiple Uses.**

1. When a building contains two or more uses, the total required number of off-street parking spaces is the sum of the requirements for each use computed separately.
2. A required off-street parking spaces for one use may not provide required off-street parking spaces for any other use except as allowed by Section 23.322.040.D (Joint Use of Parking).

H. **Including Existing Uses.** Existing off-street parking spaces shall be counted towards meeting the overall parking requirements where new floor area is added to an existing site or project.

I. **Spaces Serving Existing Uses.**

1. Unless otherwise allowed by this chapter, parking spaces serving an existing use may not be reduced below the number of spaces required by this section. If an existing use has fewer parking spaces than required by this section, the number of spaces serving the use may not be further reduced.
2. In Non-Residential Districts, off-street parking spaces provided in conjunction with a use or structure existing on October 1, 1959, on the same property or on property under the same ownership, may not be reduced below, or if already less

than, may not be further reduced below, the requirements of this chapter for a similar use or structure.

3. Existing parking spaces in a non-residential district may be removed to meet ADA compliance or traffic engineering standards.

J. In-Lieu Parking Fee.

1. General.

- a. In Non-Residential Districts with a public parking fund to create public parking, an applicant may pay a fee in lieu of providing required off-street parking spaces.
 - b. The in-lieu parking fee shall be established by City Council resolution.
 - c. In-lieu payments shall be used for the purposes stated in each ordinance establishing the public parking funds.
 - d. In-lieu fees may, at the applicant's option, be paid in a lump sum or in annual installments as specified in each ordinance establishing the parking fund and may be adjusted annually for inflation.
 - e. If paid annually, the first annual payment of an in-lieu fee is due as a condition of occupancy and subsequent payments are due on January 31 of succeeding years.
2. **C-DMU District.** Paying an in-lieu fee to reduce or waive required off-street parking in the C-DMU district requires a Use Permit. To approve the Use Permit, the ZAB must find that the applicant will pay an in-lieu fee to a fund established by the City that provides enhanced transit services.

23.322.040 – General Requirements

A. Compliance Required.

1. The City may issue a Zoning Certificate or approve an AUP or Use Permit only for a use or structure that complies with this chapter.

B. Modified Requirements.

1. **Number of Spaces.** See Section 23.322.050 (Parking Reductions) for allowed reductions to the number of required off-street parking spaces.
2. **Other Requirements.**
 - a. The Zoning Officer or ZAB may reduce any parking requirement in this chapter that is unrelated to the number of required spaces for:
 - i. New floor area created through building expansions in the Commercial, Manufacturing, and R-SMU Districts; and

- b. The times demanded for joint-use parking spaces will not conflict substantially between the land uses sharing the spaces; and
 - c. The off-street parking spaces designated for joint use are not otherwise committed to satisfying the parking requirements for another land use at similar times.
2. **Offices in R-4 and R-5 Districts.** The ZAB may approve a Use Permit to allow offices in the R-4 or R-5 district to share parking spaces with a multi-family use. To approve the Use Permit, the ZAB must find that:
- a. No more than 20 percent of the off-street parking spaces required for the multiple dwelling use will serve as required off-street parking for offices; and
 - b. The shared off-street parking spaces are located on the same lot as the offices that they serve or are on property under the same ownership within 300 feet from the offices.
3. **Deed Restriction.** A property with joint-use parking spaces shall record a deed restriction as provided in Section 23.322.040.F (Deed Restrictions).

E. Off-Site Parking Spaces.

1. **Non-Residential Districts.** In Non-Residential Districts, the following requirements apply to required parking spaces not on the property where the use is located.
- a. Off-site parking spaces may not be used to satisfy the off-street parking requirement for another use.
 - b. Off-site parking must be available during the normal hours of operation of the use that it serves.
 - c. A deed restriction must be recorded as provided in Section 23.322.040.F (Deed Restrictions). Table 23.322-5 shows the maximum distance that off-site parking spaces may be located from the use or structure it serves and the permit required to exceed this distance.

TABLE 23.322-5: OFF-SITE PARKING SPACE DISTANCE REQUIREMENTS

| District | Maximum Distance from Use or Structure [1] | Permit Required to Exceed Maximum Distance |
|--------------------------------|--|--|
| Manufacturing Districts | 500 ft. | AUP |
| C-W | 500 ft. | AUP |
| All Other Commercial Districts | 300 ft. | UP(PH) |
| <u>Note:</u> | | |

| District | Maximum Distance from Use or Structure [1] | Permit Required to Exceed Maximum Distance |
|---|--|--|
| [1] Measurement shall be from the closest two points of the respective parcels, as measured in a straight line. | | |

2. **CW District.** If the use or structure served by off-site parking is within a designated node in the C-W district, the off-site parking spaces must also be located within the same designated node.

F. Deed Restrictions.

1. If a required off-street parking space is located off-site or in a joint use agreement, a statement shall be recorded in the Office of the County Recorder that restricts the use of the property and designates the off-street parking that is to serve the other property.
2. The deed restrictions shall state that the property cannot be used so as to prevent the use of the parking requirements of the City, unless the restriction is removed by the City.
3. Upon submission of satisfactory evidence either that other parking space meeting the parking requirements has been provided or that the building or use has been removed or altered in use so as to no longer require the parking space, the City of Berkeley shall remove the restriction from the property.

G. Removal of Spaces.

1. **Permit Required.** A Use Permit is required to remove parking spaces as follows:
 - a. R-S, R-SMU, C-T districts: Removing existing off-street parking spaces for main buildings.
 - b. C-SO, C-NS districts: Removing existing off-street parking spaces in excess of the number required spaces.
2. **Findings.** To approve the Use Permit in the R-S, R-SMU, and C-T districts, the ZAB must find that the parking reduction is consistent with the purposes of the district and meets the findings in Section 23.322.050.B (Findings). No additional findings are required in the C-SO and C-NS districts.

H. Required Parking Spaces for Persons with Disabilities. If the number of required off-street parking spaces in a non-residential district is reduced as allowed by this chapter, the number of required parking spaces for persons with disabilities shall be calculated as if there had been no reduction in required spaces.

I. Nonconforming Parking – ES-R District.

1. A lawfully established use that does not provide the required number of off-street parking spaces may be continued and maintained if there is no increase in the area, space, or volume occupied by or devoted to the use, except as allowed by Paragraph (2) below.
 2. A single-family detached structure that does not provide the required number of off-street parking spaces may be increased by a cumulative total of up to 200 square feet over the floor area that existed on June 6, 2010 if:
 - a. The addition or alteration complies with all other applicable standards;
 - b. The addition or alteration is not used as a bedroom; and
 - c. No portion of the building or any other structure on the same lot is used for rental rooms.
- J. **Access to Spaces.** A building, structure, alteration, fence, landscaping, or other site feature may not be constructed, erected, planted, or allowed to be established that impedes vehicle access to a required off-street parking space.
- K. **Parking Permits.** Residents in the following projects are not eligible to receive parking permits under the Residential Permit Parking Program (RPP) as provided in Municipal Code Chapter 14.72 (Preferential Parking Program):
1. Residential projects in the R-S, R-SMU, and C-T districts that are constructed without parking.
 2. Projects in the C-DMU district with residential units or group living accommodation units, including units converted from a non-residential use.

23.322.050 – Parking Reductions

- A. **Allowed Reductions.** The Zoning Officer or ZAB may reduce or waive the number of off-street parking spaces required by Section 23.322.030 (Required Parking Spaces) for the following projects.
1. **Building Expansions.**
 - a. **Where Allowed:** All Commercial and Manufacturing Districts, R-SMU district.
 - b. **Eligible Uses:** Expansions to existing buildings (all uses).
 - c. **Required Permit:** AUP.
 - d. **Findings:** The Zoning Officer must make the findings in Subsection C (Findings) below.
 2. **Change of Use.**
 - a. **Where Allowed:** All Manufacturing Districts, R-SMU district.

- b. **Eligible Uses:** Change of use to a new use with a higher numerical parking standard. In a Manufacturing District, the reduction is allowed only if the change of use is 2,500 square feet or less.
 - c. **Required Permit:** Use Permit for projects that require ZAB approval. AUP for all other projects.
 - d. **Findings:** The review authority must make the findings in Subsection C (Findings) below.
3. **Non-Residential Uses in Main Residential Building.**
- a. **Where Allowed:** R-SMU district.
 - b. **Eligible Uses:** Non-residential uses in main buildings that contain dwelling units or group living accommodations.
 - c. **Required Permit:** AUP.
 - d. **Findings:** To approve the AUP, the Zoning Officer must find that the parking reduction is consistent with the purposes of the R-SMU district as stated in 23.202.140.A (District Purpose).
4. **Residential Uses in Mixed-Use Buildings.**
- a. **Where Allowed:** All districts.
 - b. **Eligible Uses:** The residential use portion of a mixed-use building (residential and commercial).
 - c. **Required Permit:** AUP
 - d. **Findings:** To approve the Use Permit, the ZAB must make findings in each district chapter:
 - i.* C-C district: 23.204.050.D.3.b
 - ii.* C-U district: 23.204.060.D.3.b
 - iii.* C-N district: 23.204.070.D.3.b
 - iv.* C-SA district: 23.204.100.D.2
 - v.* C-SO district: 23.204.120.D.2
5. **Exclusive Residential Uses.**
- a. **Where Allowed:** All districts.
 - b. **Eligible Uses:** Buildings occupied exclusively by residential uses.
 - c. **Required Permit:** AUP

- d. **Findings:** To approve the AUP, the Zoning Officer must make findings in each district chapter:
 - i. C-C district: 23.204.050.D3.b
 - ii. CU district: 23.204.060.D.3.b
 - iii. C-N district: 23.204.070.D.3.b
 - iv. C-SA district: 23.204.100.D.2
 - v. C-SO district: 23.204.120.D.2

6. **Commercial Uses in Mixed-Use Building.**

- a. **Where Allowed:** C-C, CU, C-SA districts.
- b. **Location Limitations:** In the C-C, C-U districts, the reduction is allowed only on blocks adjacent to University Avenue and lots north of University Avenue, south of Delaware Street, east of Bonita Avenue and west of Oxford Street.
- c. **Eligible Uses:** Any commercial use portion of a mixed-use building which combines retail products stores and/or personal household services and multi-family residential uses within the same building or located on the same lot (or contiguous lots as part of the same project).
- d. **Required Permit:** Use Permit.
- e. **Findings:** The ZAB must make the findings in Subsection C (Findings) below.

7. **All Uses in Mixed-Use Building.**

- a. **Where Allowed:** C-W district.
- b. **Eligible Uses:** All uses in a mixed-use building (residential and commercial).
- c. **Permit Required:** Use Permit for projects that require ZAB approval. AUP for all other projects.
- d. **Finding:** To approve the permit, the review authority must find that:
 - i. The reduction promotes any of the C-W district purpose statements in 23.204.140.A (District Purpose); and
 - ii. The reduction in the parking requirement is not expected to cause a serious shortage of parking in the area.

8. **Bicycle/Motorcycle Spaces.**

- a. **Where Allowed:** C-W and all Manufacturing Districts.
- b. **Eligible Uses:** All uses.

- c. **Allowed Reduction:** Up to 10 percent of required off-street automobile spaces may be designated as bicycle and/or motorcycle parking. Bicycle parking must be in addition to bicycle parking required by 23.322.090 (Bicycle Parking).
- d. **Permit Required:** Use Permit for projects that require ZAB approval. AUP for all other projects.
- e. **Finding:** To approve the permit, the review authority must find that:
 - i. The substitution will not lead to an undue shortage of automobile parking spaces; and
 - ii. It can be reasonably expected that there will be demand for the bicycle and/or motorcycle parking spaces.

9. Proximity to Public Parking Facility.

- a. **Where Allowed:** C-W district.
- b. **Eligible Uses:** All uses within 1,000 feet of a public parking facility available to all members of the public.
- c. **Permit Required:** Use Permit.
- d. **Finding:** No additional findings.

10. Downtown Reduction/Waiver.

- a. **Where Allowed:** C-DMU district.
- b. **Eligible Uses:** All uses.
- c. **Permit Required:** Use Permit or modified with an AUP.
- d. **Finding:** The Zoning Officer must make the findings in Subsection C (Findings) below.

11. Adding Residential Units.

- a. **Where Allowed:** MU-R district.
- b. **When Allowed:** Adding a residential unit to a property with one or more existing residential units.
- c. **Permit Required:** AUP
- d. **Findings.** To approve the AUP Permit, the ZAB must find that:
 - i. Existing evening parking supply is adequate; and/or
 - ii. Other mitigating circumstances exist on the property.

12. Limited Duration Reduction.

- a. **Where Allowed:** M and MM District.
- b. **Eligible Uses:** All uses.
- c. **Permit Required:** Use Permit valid for a specified duration not to exceed five years.
- d. **Findings.** To approve the Use Permit, the ZAB must find that under the circumstances of the particular use and building, the demand for parking can be expected to be below the otherwise required level for a sustained period of time.

B. Findings. Required findings below are in addition to permit findings required in Section 23.406 (Specific Permit Requirements).

- 1. **Commercial, R-S, and R-SMU Districts.** When required by Subsection A (Allowed Reductions) above or elsewhere in the Zoning Ordinance, the review authority must make the following findings to approve a reduction in required off-street parking spaces in a Commercial District, the R-S district, or the R-SMU district:
 - a. The reduction will not substantially reduce the availability of on-street parking in the vicinity of the use.
 - b. One of the following is true:
 - i.* The use is located one-third of a mile or less from a Bay Area Rapid Transit (BART) station, intercity rail station or rapid bus transit stops.
 - ii.* The use is located one-quarter of a mile or less from a public or private parking area, lot, or structure that is accessible by the employees of the use and sufficient parking supply is available therein to mitigate the reduction in parking for the use.
 - iii.* A parking survey conducted under procedures set forth by the Planning Department finds that within 500 feet or less of the use, on non-residential district streets, at least two times the number of spaces requested for reduction are available at on-street parking spaces during the peak hours of operation of the use.
 - c. One of the following is true:
 - i.* The parking requirement modification will meet the purposes of the district related to improvement and support for alternative transportation, pedestrian improvements, and activity, or similar policies.
 - ii.* There are other factors, such as alternative transportation demand management strategies or policies in place, that will reduce the parking demand generated by the use.

2. **Manufacturing Districts.** When required by Subsection A (Allowed Reductions) above or elsewhere in the Zoning Ordinance, the review authority must make the following findings to approve a reduction in required off-street parking spaces in a Manufacturing District:
 - a. The reduction will not substantially reduce the availability of on-street parking in the vicinity of the use.
 - b. One of the following is true:
 - i.* The use is located one-third of a mile or less from a rapid bus transit stop, an intercity rail station, or a bus stop serving at least four lines.
 - ii.* The use is located one-quarter of a mile or less from a public or private parking area, lot, or structure that is accessible by the employees of the use and sufficient parking supply is available in these facilities to mitigate the reduction in parking.
 - iii.* A parking survey conducted under procedures set forth by the Planning Department finds that within 500 feet or less of the use, on non-residential district streets, at least two times the number of spaces requested for reduction are available at on-street parking spaces during the peak hours of operation of the use.
 - c. One of the following is true:
 - i.* The parking requirement modification will implement the West Berkeley Plan goals and policies related to improvement and support for alternative transportation, pedestrian improvements and activity, and similar policies.
 - ii.* There are other project-specific transportation demand management strategies or policies in place, including but not limited to employer sponsored transit subsidies, car sharing programs, bicycle storage, and flexible work schedules.

23.322.060 – C-DMU Parking and Transportation Demand Management

The parking and transportation demand management requirements in this section apply in the C-DMU district.

A. Dynamic Signage.

1. New construction that results in an off-street total of more than 25 publicly available parking spaces shall install dynamic signage to Transportation Division specifications.
2. Required signage includes, but is not limited to:

- a. Real-time garage occupancy signs at the entries and exits to the parking facility with vehicle detection capabilities and enabled for future connection to the regional 511 Travel Information System; or
- b. Equivalent signs as determined by the Zoning Officer in consultation with the Transportation Division Manager.

B. Unbundled Parking.

- 1. For any new building with residential units or structures converted to a residential use, required parking spaces shall be leased or sold separate from the rental or purchase of dwelling units for the life of the dwelling unit.
- 2. The ZAB may approve a Use Permit to waive the requirement in Paragraph (1) above for projects that include financing for affordable housing. To approve the Use Permit, the ZAB must find that the applicant has shown that the combined parking is necessary to obtain financing or meeting other obligations.

C. Employee/Resident Benefits.

- 1. For new structures or additions over 20,000 square feet, the property owner shall provide at least one of the following transportation benefits at no cost to every employee, residential unit, and/or group living accommodation resident:
 - a. A pass for unlimited local bus transit service; or
 - b. A functionally equivalent transit benefit in an amount at least equal to the price of a non-discounted unlimited monthly local bus pass. Any benefit proposed as a functionally equivalent transportation benefit shall be approved by the Zoning Officer in consultation with the Transportation Division Manager.
- 2. A notice describing these transportation benefits shall be posted in a location visible to employees and residents.

D. Vehicle Sharing Spaces.

- 1. **Spaces Required.** For residential structures constructed or converted from a non-residential use that provide off-street parking, vehicle sharing spaces shall be provided in the amounts shown in Table 23.322-6. Vehicle sharing spaces are not required for projects that do not provide off-street vehicle parking.

TABLE 23.322-6: REQUIRED VEHICLE SHARING SPACES

| Number of Parking Spaces Provided | Minimum Number of Vehicle Sharing Spaces |
|--|---|
| 0-10 | 0 |
| 11-30 | 1 |
| 31-60 | 2 |

| Number of Parking Spaces Provided | Minimum Number of Vehicle Sharing Spaces |
|-----------------------------------|--|
| 61 or more | 3, plus one for every additional 60 spaces |

2. Requirements.

- a. The required vehicle sharing spaces shall be offered to vehicle sharing service providers at no cost.
- b. The vehicle sharing spaces shall remain available to a vehicle sharing service provider as long as providers request the spaces.
- c. If no vehicle sharing service provider requests a space, the space may be leased for use by other vehicles.
- d. When a vehicle sharing service provider requests such space, the property owner shall make the space available within 90 days.

E. Parking and Transportation Demand Management Compliance Report.

- 1. Before issuance of a Certificate of Occupancy, the property owner shall submit to the Department of Transportation a completed Parking and Transportation Demand Management (PTDM) compliance report on a form acceptable to the City of Berkeley.
- 2. The property owner shall submit to the Department of Transportation an updated PTDM compliance report on an annual basis.

23.322.070 – Off-Street Parking Maximums for Residential Development

A. Applicability.

- 1. This section applies to new residential projects with two or more dwelling units on a parcel, including the residential portion of mixed-use projects, where any portion of the project is located either:
 - a. Within 0.25 miles of a major transit stop, as defined by Section 21064.3 of the California Public Resources Code; or
 - b. Along a transit corridor with service at 15-minute headways during the morning and afternoon peak periods.
- 2. **Exemptions.** The following types of projects are exempt from the requirements of this section:
 - a. Projects for which a building permit was issued before March 19, 2021.
 - b. Residential projects, including the residential portions of mixed-use projects, with the majority of the units subject to recorded affordability restrictions;

- c. Projects located on a roadway with less than 26 feet pavement width in the Hillside Overlay.
- d. Projects located in the Environment Safety-Residential (ES-R) district.

B. Off-Street Parking Maximum. Any project subject to this chapter shall not include off-street residential parking at a rate higher than 0.5 parking spaces per Dwelling Unit.

C. Adding Units to Existing Buildings or Properties.

- 1. The parking maximum required by this section applies to new dwelling units added to an existing property or building where the addition results in two or more units on the parcel.
- 2. Adding a unit to an existing property or building does not require the removal of any existing off-street parking spaces.

D. Excess Off-Street Parking.

- 1. Off-street residential parking in excess of the maximum number in Section 23.322.070.B (Off-Street Parking Maximum) may be approved with an AUP.
- 2. To approve an AUP for excess off-street parking, the review authority must make one or both of the following findings:
 - a. Trips to the use or uses to be served, and the apparent demand for additional parking, cannot be satisfied by the amount of parking permitted by this section, by transit service which exists or is likely to be provided in the foreseeable future, or by more efficient use of existing on-street and off-street parking available in the area;
 - b. The anticipated residents of the proposed project have special needs or require reasonable accommodation that relate to disability, health or safety that require the provision of additional off-street residential parking.

23.322.080 – Parking Layout and Design

A. Traffic Engineering Requirements.

- 1. All off-street parking spaces, access driveways, circulation patterns, and ingress and egress connections to the public right-of-way must conform to the City of Berkeley's Traffic Engineering requirements.
- 2. The Traffic Engineer shall determine whether the size, arrangement, and design of off-street parking spaces, access driveways, circulation patterns, and ingress and egress connections to the public right-of-way are adequate to create usable, functional, accessible, and safe parking areas, and are adequately integrated with Berkeley's overall street pattern and traffic flows.

B. Dimensional Standards. Dimensional requirements and standards for off-street parking spaces, driveways, and other access improvements, and maneuvering aisles shall be incorporated in administrative regulations, subject to the review and approval by the City Manager and ZAB.

C. Access Orientation in Non-Residential Districts. Access to new parking areas in a Non-Residential District that serve commercial uses shall be oriented in such a way as to minimize the use of streets serving primarily residential uses.

D. Placement – Residential Districts.

1. Side Setback Areas.

- a. One new off-street parking space in a required side setback area, where none exists, is allowed by right.
- b. The space must be constructed of a permeable surface unless the Public Works Department or Office of Transportation determines it is infeasible.
- c. The space must be screened as required by 23.322.080.G (Screening).
- d. The location of the space shall minimize impact on usable open space.

2. Other Setback Areas. No portion of an off-street parking space may be located in a required front, street side, or rear setback area unless:

- a. The parking space location is authorized by Chapter 23.306 (Accessory Dwelling Units); or
- b. The Zoning Officer approves an AUP, in consultation with the Traffic Engineer, and the space meets all applicable requirements in this section.

3. Multifamily Buildings.

- a. An off-street parking space may not be located closer than 10 feet in horizontal distance from a door or a window of a building with three or more dwelling units where the space is on the same or approximately the same level as the building.
- b. For the purposes of this section, a window whose bottom edge or point is more than 6 feet in vertical height from the level of the subject off-street parking space is not considered on the same or approximately the same level.
- c. The Zoning Officer may approve an AUP to grant an exception to this requirement.

E. Placement – Non-Residential Districts.

1. **Where Prohibited.** Except when otherwise allowed by this chapter, ground-level off-street parking spaces are not permitted within 20 feet of the lot's street frontage unless the parking is entirely within a building with walls.
2. **Corner Lots.** For a corner lot, the ZAB may approve a Use Permit to allow the parking within 20 feet of the street frontage facing the secondary street.
3. **C-W District.**
 - a. Off-street automobile parking in the C-W district is not permitted between the front lot line and a main structure within a designated node.
 - b. Outside of a designated node, off-street automobile parking may be allowed between the front lot line and a main structure with a Use Permit or AUP. If the project requires ZAB approval, a Use Permit is required. An AUP is required for all other projects.
 - c. To approve the AUP or Use Permit, the review authority must find that one or more of the following is true:
 - i. Parking in the rear or on the side of the property is impractical because of the lot's depth and/or width.
 - ii. Parking in the rear of the property would result in adverse impacts on abutting residential or other uses.
 - iii. Parking in the rear or on the side of the property would result in the placement of a driveway in an unsafe location.
 - iv. Continuation or re-establishment of parking in front of the building is necessary for the reuse of an existing structure which is substantially set back from the front lot line.

F. **Grade Change.** This subsection applies to off-street parking spaces in all districts, except for parking decks in Residential Districts.

1. The difference in elevation between a parking space and the finished grade on adjacent areas of the lot may not exceed 5 feet at any point.
2. Where there is a difference in elevation between a parking space and adjacent finished grade, the parking space shall be setback from a lot line as shown in Table 23.322-7.

TABLE 23.322-7: REQUIRED SETBACKS FOR PARKING SPACES WITH ADJACENT GRADE CHANGES

| Difference in Elevation | Minimum Setback |
|---|-----------------|
| Parking space lower than finished grade | |
| 3 to 5 ft | 4 ft. |

| Difference in Elevation | Minimum Setback |
|--|-----------------|
| Less than 3 ft | No min. setback |
| Parking space higher than finished grade | 6 ft. |

G. Screening.

- 1.
2. Table 23.322-8 shows required parking space screening. Screening must effectively screen parked vehicles from view from buildings and uses on adjacent, abutting, and confronting lots. Screening may not interfere with pedestrian safety.

TABLE 23.322-8: REQUIRED PARKING SPACE SCREENING

| Districts | When Required | Required Screening Feature | Screening Feature Height |
|--|---|---|---|
| All Residential Districts | 2 or more parking spaces, or any parking space partly or entirely within a required rear setback area | Continuous view-obscuring wood fence, masonry wall, or evergreen hedge which may be broken only for access driveways and walkways | 4 ft. min and 6 ft. max. |
| All Commercial and Manufacturing Districts | 2 or more parking spaces | Wall, fence, or evergreen shrubbery hedge in a landscape strip | Parking adjacent to public right-of-way or front lot line: 3 ft. min. and 4 ft. max. Parking adjacent to rear or side lot line: 4 ft. min and 6 ft. max. |

3. In the C-W, M, MM, MU-LI districts, screening and landscape buffers are not required for any portion of a parking lot adjacent to Third Street (Southern Pacific Railroad).

H. Landscape Buffers.

1. All paved areas for off-street parking spaces, driveways, and any other vehicle-related paving must be separated from adjacent lot lines and the public right-of-way by a landscaped strip as shown in Table 23.322-9.

TABLE 23.322-9: REQUIRED LANDSCAPE BUFFERS

| District/Number of Spaces | Minimum Width of Landscape Strip | |
|---|--|---|
| | Areas adjacent to side or rear lot lines | Areas adjacent to public right-of-way or front lot line |
| Residential Districts | | |
| 1-3 spaces | 2 ft. | 2 ft. |
| 4 spaces or more | 4 ft. [1] | 4 ft. [1] |
| Commercial and Manufacturing Districts | | |
| 1 space | None required | None required |
| 2-3 spaces | 2 ft. | 3 ft. |
| 4 spaces or more | 4 ft. [1] | 4 ft. [1] |

Note:

[1] Calculated as average width along the full length of landscape strip.

2. In all districts, this landscape buffer requirement does not apply to driveways that serve two adjacent lots when adjacent to a side lot line.
3. In the Residential Districts, this landscape buffer requirement also does not apply to pedestrian walkways that are separated from such areas by a landscaped strip at least two feet wide.

I. Paved Setback Areas. In Residential Districts, the total area of pavement devoted to off-street parking spaces, driveways, and other vehicle-related paving may not exceed 50 percent of any required setback area that runs parallel to and abuts a street.

J. Driveway Width.

1. A driveway may not exceed 20 feet in width at any lot line abutting a street or one-half of the width of the street frontage of the lot, whichever is less.
2. In a Non-Residential district, the Zoning Officer may modify this requirement with an AUP.

K. Driveway Separation. On a single lot in a Residential District, driveways must be spaced at least 75 feet from one another, as measured along any continuous lot line abutting a street.

L. Tandem Parking. Tandem spaces that provide required off-street parking require an AUP, except when allowed by right by Chapter 23.306 (Accessory Dwelling Units).

M. **Residential Parking Lots in Non-Residential Districts.** Parking lots in a non-residential district used exclusively for residential parking must comply with standards in this section that apply in Residential Districts.

N. **Carports.** A carport shall meet the minimum horizontal and vertical dimensions specified by the City's Traffic Engineer to be used for one or more legal parking spaces required under this chapter.

23.322.090 – Bicycle Parking

A. Parking Spaces Required.

1. **Non-Residential Bicycle Parking.** Table 23.322-10 shows districts where bicycle parking is required, land uses requiring bicycle parking, and the number of required spaces. Bicycle parking is required for new construction and for expansions to existing buildings that add new floor area.

TABLE 23.322-10: REQUIRED NON-RESIDENTIAL BICYCLE PARKING

| District | When Required | Required Spaces |
|--|--|---------------------|
| R-S, R-SMU | New commercial space | 1 per 2,000 sq. ft. |
| All Commercial Districts except for C-E and C-T | New floor area or for expansions of existing industrial, commercial, and other non-residential buildings | 1 per 2,000 sq. ft. |
| All Manufacturing Districts except for C-E and C-T | New floor area or for expansions of existing industrial, commercial, and other non-residential buildings | 1 per 2,000 sq. ft. |
| C-E, C-T | None required | N/A |

a. In the C-DMU district, the Zoning Officer, in consultation with the City Traffic Engineer, may approve an AUP to modify the bicycle parking requirement in Table 23.322-10 for Tourist Hotels.

2. **Residential Parking.** Table 23.322-11 shows the types of residential projects, including the residential portion of mixed-use projects, for which bicycle parking is required.

TABLE 23.322-11: REQUIRED RESIDENTIAL BICYCLE PARKING

| Use | Long-Term Parking Requirement [1] | Short-Term Parking Requirement [1] |
|----------------------------------|-----------------------------------|---|
| Dwelling Units (1 to 4 units) | None required | None required |
| Dwelling Units (5 units or more) | 1 space per 3 bedrooms | 2, or 1 space per 40 bedrooms, whichever is |

| Use | Long-Term Parking Requirement [1] | Short-Term Parking Requirement [1] |
|---|--|---|
| | | greater |
| Group Living Accommodations, Dormitories, Fraternity and Sorority Houses, Rooming and Boarding Houses, Transitional Housing | 2, or 1 space per 2.5 bedrooms, whichever is greater | 2, or 1 space per 20 bedrooms, whichever is greater |
| [1] Long-Term Parking and Short-Term Parking shall meet the design standards included in Appendix F of the 2017 <i>Berkeley Bicycle Plan</i> , or as subsequently amended by the Transportation Division. | | |

B. Bicycle Parking Standards. The following standards apply to required bicycle parking spaces in a non-residential district:

1. Bicycle parking spaces shall be located in either a locker, or in a rack suitable for secure locks, and shall require location approval by the City Traffic Engineer and Zoning Officer.
2. Bicycle parking shall be located in accordance to the Design Review Guidelines and other design specifications promulgated by the Transportation Division.

23.322.100 – On-site Loading Spaces

A. When Required. Table 23.322-12 shows land uses that require on-site loading spaces consistent with this section. In Residential Districts, on-site loading spaces are required for any modifications to existing uses and for new construction. In Commercial and Manufacturing Districts, on-site loading spaces are required for new or additional construction of 10,000 square feet or more.

TABLE 23.322-12: LAND USES REQUIRING OFF-STREET LOADING SPACES

| District | Land Use [1] |
|----------------|--|
| R-1, R-1A, R-2 | Schools 10,000 sq. ft. or more |
| R-2A | Senior congregate housing, nursing homes and schools 10,000 sq. ft. or more |
| R-3 | Senior congregate housing, hospitals, nursing homes, schools 10,000 sq. ft. or more |
| R-4, R-5 | Senior congregate housing, hospitals, nursing homes, offices, schools 10,000 sq. ft. or more |
| R-S, R-SMU | All non-residential uses 10,000 sq. ft. or more |

| District | Land Use [1] |
|--|--|
| All C Districts except C-T | All commercial uses 10,000 sq. ft. or more |
| C-T | No loading spaces required for all land uses |
| M Districts | All commercial and manufacturing uses 10,000 sq. ft. or more |
| <u>Note:</u> [1] Land use size is total gross floor area. | |

B. Number of Loading Spaces. For land uses that require an on-site loading space, Table 23.322-13 shows the minimum number of required spaces.

TABLE 23.322-13: NUMBER OF REQUIRED OFF-STREET LOADING SPACES

| District | Spaces Required [1] |
|--|--|
| Residential and Commercial Districts | 1 space for the first 10,000 sq. ft. plus 1 additional space for each additional 40,000 sq. ft |
| Manufacturing Districts | 1 space for the first 10,000 sq. ft. plus 1 additional space for each additional 25,000 sq. ft |
| <u>Note:</u> [1] Land use size is total gross floor area. | |

C. Loading Space Requirements.

1. **General.** The following requirements apply to required on-site loading spaces in all districts except for the R-1, R-1A, R-2, R-2A districts.
 - a. **Dimensions.** A required loading space must be at least 12 feet wide and 25 feet long with a minimum vertical clearance of 14 feet.
 - b. **Location.** A required loading spaces must be located on the same lot as the structure or use the space is designed to serve.
 - c. **Parking Spaces.** A required parking space may not be used to satisfy the requirements for an off-street loading space.
 - d. **Access and Paving.** A required loading space must have adequate means of access from a street or alley. Both the space and access driveway must be paved with a durable, dustless material that is usable under all weather conditions.
2. **Residential Buffer.** An on-site loading space in a Non-Residential District may not be located within 35 feet of a lot in a Residential District unless the loading space is either:

- a. Located wholly within an enclosed building; or
 - b. Screened from such residential lot by a wall, hedge, or fence not less than 6 feet in height.
3. **C-W District.** A building or site in the C-W district may not be altered to deprive a leasable space used or designated for use by any manufacturing or wholesale trade of an on-site loading space consistent with Paragraph 1 (All Districts) above.
 4. **M and MM Districts.** All uses in the M and MM districts which have one or more on-site loading spaces shall retain at least one such space.
 5. **Modified Requirements.** In all Manufacturing and Commercial Districts other than the C-T district, the Zoning Officer in consultation with the City Traffic Engineer may approve an AUP to modify the on-site loading spaces standards in this section.

23.322.110 – Parking Lots in Residential Districts

- A. **Applicability.** This section applies to the exclusive or primary use of a lot for off-street parking spaces in a Residential District.
- B. **Use Limitations.** Commercial repair work or service of any kind is prohibited on the lot.
- C. **Standards.**
 1. Signs may only designate the parking lot name, entrances, exits, and conditions of use. No other types of signs may be erected or maintained.
 2. Lighting fixtures must be oriented to direct the light away from adjacent lots.
 3. Suitable wheel bumpers must be provided to protect screening and adjacent property.
 4. A durable and dustless surface must be provided and maintained.
 5. The lot must comply with 23.322.070.G (Screening) and 23.322.070.H (Landscape Buffers).
 6. The lot must be graded to dispose of all surface water.
- D. **Exceptions.** The ZAB may waive any of the requirements in this section with a Use Permit for a temporary parking lot.

23.322.120 – Transportation Services Fee

- A. **When Required.**

1. A Transportation Services Fee (TSF) may be required for all new construction of gross floor area pursuant to resolution of the City Council.
2. If so resolved, the following districts are required to pay a TSF: R-S, R-SMU, C-C, C-U, C-N, C-NS, C-T, C-SO, M, and MM.

B. Paying and Collecting Fees.

1. All TSF payments shall be made to the Finance Department and deposited into the City or Berkeley's traffic/transportation mitigation fund.
2. TSF payments shall be collected in the form of annual payments based on the fee rate applicable to each district multiplied by the square feet of gross floor area of new construction and may be adjusted annually for inflation.
3. TSF payments shall be made for 30 years from the issuance of a certificate of occupancy for any new floor area.
4. The first annual payment of the TSF shall be due as a condition of occupancy and subsequent payments shall be due on January 1 of each succeeding year for 29 years.

- C. Use of Funds.** TSF funds shall be used to purchase transit or paratransit passes, coupons, and tickets to be made available at a discount to employees and customers and to promote and support incentives for employee ride sharing.

23.324 NONCONFORMING USES, STRUCTURES, AND BUILDINGS

Sections:

- 23.324.010– Chapter Purpose
- 23.324.020– General
- 23.324.030– Nonconforming Lots
- 23.324.040– Nonconforming Uses
- 23.324.050– Nonconforming Structures and Buildings
- 23.324.060– Exemptions

23.324.010 – Chapter Purpose

This chapter establishes regulations for nonconforming lots, uses, structures, and buildings. These regulations are intended allow for:

- A. The development and use of lawful nonconforming lots;
- B. Changes to nonconforming uses and the termination of abandoned uses;
- C. Maintenance, repair, and expansion of nonconforming structures and buildings; and
- D. Alterations to nonconforming structures and buildings when needed for public safety.

23.324.020 – General

- A. **Cause of Nonconformity.** A nonconformity may result from any inconsistency with the Zoning Ordinance, whether substantive or procedural, including, but not limited to:
 - 1. The inconsistency of the use, building, or structure or aspects thereof, with any requirement of the Zoning Ordinance; and
 - 2. The lack of a Zoning Certificate, AUP, or Use Permit.
- B. **Change to a Conforming Use or Structure.** A use, building, or structure which is nonconforming solely by reason of the lack of a Zoning Certificate, AUP, or Use Permit may be recognized as a conforming use, building, or structure by issuance of the required Zoning Certificate, AUP, or Use Permit.
- C. **Permit and Approvals Required.** A use, building, or structure conforms to the Zoning Ordinance only if it was established or constructed with the prior approval of, or legalized after the fact by, the issuance of the required Zoning Certificate, AUP, or Use Permit.
- D. **Nonconformities in Continuous Existence.** A lawful nonconforming use, structure, building, or lot shall be deemed to comply with the Zoning Ordinance if it has remained in continuous existence.

23.324.030 – Nonconforming Lots

A. Lawful Nonconforming Lots. A lot with an area less than the minimum lot size required by the Zoning Ordinance is considered a lawful nonconforming lot if the lot is:

1. Described in the official records on file in the office of the County Recorder of Alameda County or Contra Costa County as a lot of record under one ownership before November 30, 1950;
2. Shown as a lot on any recorded subdivision map, filed before November 30, 1950; or
3. In the Environmental Safety Residential (ES-R) district and described in the official records on file in the office of the County Recorder of Alameda County as either:
 - a. A lot of record under one ownership; or
 - b. A lot on any recorded subdivision map filed before February 13, 1975.

B. Requirements.

1. A lawful nonconforming lot may be used as building site subject to all other requirements of the Zoning Ordinance, except as provided in Paragraph (2) below.
2. If the total area of all contiguous vacant lots fronting on the same street and under the same ownership on or after September 1, 1958 is less than that required for one lot under the Zoning Ordinance, such lawful nonconforming lots may be used as only one building site.

23.324.040 – Nonconforming Uses

A. Changes to Nonconforming Uses.

1. Table 23.324-1 shows permits required to change a lawful nonconforming use.

TABLE 23.324-1: PERMIT REQUIREMENTS FOR CHANGES TO NONCONFORMING USES

| Change to Nonconforming Use | Permit Required |
|---|-----------------|
| Changes to a use that is allowed by right, complies with floor area requirements, conforms to all applicable requirements of the Zoning Ordinance excluding parking requirements, and is in a conforming building | ZC |
| Any change to a nonconforming use that does not require a Zoning Certificate or Use Permit by this table | AUP |
| Any project that substantially expands or changes a nonconforming use | UP(PH) [1] |
| <p><u>Notes:</u> [1] In the ES-R district the increase in the area, space, or volume occupied by or devoted to a lawful nonconforming use is not allowed.</p> | |

2. Substantial expansions and changes to a nonconforming use, as used in Table 23.324-1, means:
 - a. All changes to a use listed in 23.404.070.B (Permit Modification Required); and
 - b. Extending the nonconforming use into an existing or expanded portion of a building which has not been previously occupied by that nonconforming use.

B. Abandoned Uses.

1. **Termination.**
 - a. Subject to the exceptions in Paragraph 2 (Exceptions) below, the ZAB may declare a lawful nonconforming use to be terminated upon finding that:
 - i.* The use has not occurred for at least one year; and
 - ii.* The most recent prior user has not shown a good-faith intent to resume it.
 - b. The ZAB may require any person claiming that the use should not be declared terminated to produce documentation to substantiate good faith intent to resume the use.
2. **Exceptions.**
 - a. **Residential Uses.** No lawful residential use can lapse, regardless of the length of time of the non-use.
 - b. **Uses with Major Investments.** Lawful nonconforming full or quick service restaurants with cooking or food preparation facilities, gas/auto fuel stations, theaters, manufacturing plants with specifically designed fixed facilities and

other uses which represent a major investment in physical plant or facilities shall not be considered or declared terminated, regardless of the duration of non-use, unless:

- i.* Such fixed structures, equipment, or facilities are removed; or
 - ii.* Other uses could not be established without major removal of or extensive remodeling or replacement of structures associated with the previous established use.
- c. **Alcoholic Beverage Retail Sales.** If a lawful nonconforming alcoholic beverage retail sale use is closed is more than 90 days, the Zoning Adjustments Board (ZAB) may not declare the use terminated if the use was closed due to:
- i.* Repair that does not change the nature of the license premises or increase the square footage of the business used for alcoholic beverages sales; or
 - ii.* Restoration of premises made totally or partially unusable by an act of nature, fire, accident, or other involuntary cause where the restoration does not increase the square footage of the business used for alcoholic beverage sales.

23.324.050 – Nonconforming Structures and Buildings

- A. **Maintenance and Repair.** A lawful nonconforming structure or building may be maintained and repaired, as long as such maintenance or repair does not result in a change to the use of the structure or building.
- B. **Replacement.** Replacing portions of a nonconforming structure or building is allowed if the removed portions were lawfully constructed and are replaced to the same size, height, extent, and configuration as previously existed.
- C. **Removal.**
 - 1. A nonconforming portion of a nonconforming structure or building may be removed by right if such removal does not constitute demolition.
 - 2. For a structure or building subject to the Landmarks Preservation Ordinance, the regulations under Municipal Code Section 3.24 (Landmarks Preservation Commission) apply.
- D. **Expansion and Alteration.**
 - 1. **General.** An addition to or enlargements of a lawful nonconforming structure or building is allowed if:
 - a. The addition or enlargement complies with all applicable laws;

- b. The existing use of the structure or building is conforming, except as provided below in Paragraph 4 (Property with Nonconforming Use); and
- c. The addition or enlargement obtains all permits required by this subsection.

2. Nonconforming Setbacks and Height.

- a. An AUP is required for an addition or enlargement that:
 - i.* Vertically or horizontally extends a building wall projecting into a minimum required setback;
 - ii.* Horizontally extends the portion of a building exceeding the height limit;
 - iii.* Alters the portion of a building (including windows and other openings) projecting into a minimum required setback; or
 - iv.* Alters the portion of a building exceeding the height limit.
- b. The Zoning Officer may approve the AUP only if:
 - i.* The addition or enlargement does not increase or exacerbate any nonconforming setbacks; and
 - ii.* The addition or enlargement does not exceed maximum or calculated height limits.

3. Nonconforming Coverage, FAR, and Density.

- a. A Use Permit is required for an addition to and/or enlargement of a structure or building that exceeds the maximum allowed lot coverage, floor area ratio, or residential density.
- b. The ZAB may approve the Use Permit only if the project does not:
 - i.* Increase or exacerbate the nonconformity; or
 - ii.* Exceed the height limit.

4. Property with Nonconforming Use.

- a. A Use Permit is required for an addition to and/or enlargement of a lawful nonconforming structure or building on a property with a lawful nonconforming use.
- b. The Use Permit is required whether or not the nonconforming use occupies the subject structure or building.

E. Tenant Space Reconfigurations.

- 1. The reconfiguration of non-residential tenant space in a nonconforming structure or building requires permits as follows:

- a. AUP for structures or buildings nonconforming to setback, height, or lot coverage standards.
 - b. Use Permit for structures or buildings nonconforming to FAR standards.
2. The reconfiguration is allowed only if the existing use of the property is conforming.

F. Damage and Reconstruction.

1. **Calculation of Appraisal Value.** As used in this subsection, the “appraised value” of a structure or building is the higher of:
 - a. The records of the Assessor of the County of Alameda for the fiscal year during which such destruction occurred; or
 - b. An appraisal performed by a certified appraiser.
2. **Damage Less than 50 Percent.** If 50 percent or less of its appraised value of a lawful nonconforming structure or building is damaged or destroyed for any reason, the replacement of the damaged portions of the structure or building is allowed by right if the replaced portions are the same size, extent, and configuration as previously existed.
3. **Damage More than 50 Percent.**
 - a. Except as provided in Paragraph 4 (Residential Buildings with Four Units or Less) below, if more than 50 percent of the appraised value of a lawful nonconforming structure or building is damaged or destroyed for any reason, the structure or building shall either:
 - i. Be brought into full compliance with the requirements of the Zoning Ordinance; or
 - ii. Receive ZAB approval of a Use Permit for the structure or building to be rebuilt to the same size, extent, and configuration as previously existed. To approve the Use Permit, the ZAB must find that the previous use will be continued in a manner that meets the requirements of this chapter.
4. **Residential Structures or Buildings with Four Units or Less.**
 - a. A residential-only structure or building with four residential units or less, including any accessory structures or buildings, that is involuntarily damaged or destroyed may be replaced or reconstructed with a Zoning Certificate.
 - b. The Zoning Certificate may be approved only if all of the following conditions exist:
 - i. The structure or building, or any portion thereof, has been destroyed by any involuntary cause including fire, earthquake, or flood.

- ii. The replacement structure or building or portion thereof is substantially similar in use, dimensions, floor area, square footage, envelope, lot coverage, footprint, and number of units to the destroyed structure or building or portion thereof that it is designed to replace.
 - iii. The replacement or repair complies with all currently applicable building codes and any other regulations including any ordinance or emergency regulation adopted by the City Council or the Director of Emergency Services to protect against serious safety problems at the site such as engineering conditions and soil stability.
- c. Where a structure or building to be replaced or rebuilt does not conform to Paragraph (b)(ii) above and is to be expanded or changed, the structure or building is subject to all otherwise applicable regulations governing such expansion or change.
 - d. The Planning Director shall establish a process that allows an owner of a qualifying residential structure or building to apply for an advance determination that the proposed repair or replacement of a structure or building is substantially similar as required by Paragraph (b)(ii) above including the information required to document existing conditions.
 - e. The Planning Director shall develop a description or building information for owners of qualifying residential structures or buildings required by the City to document existing characteristics of the building in case of future damage or destruction.

23.324.060 – Exemptions

A. Public Safety Structural Alterations.

1. **General.** The following public safety structural alterations or extensions to conforming and nonconforming buildings are permitted by right to the extent necessary, as determined by the Zoning Officer:
 - a. Vertical and/or horizontal extensions of a nonconforming setback.
 - b. Horizontal extensions of a nonconforming height.
 - c. Vertical extensions of a nonconforming height in residential districts.
 - d. Alterations of a portion of a building that encroaches into a nonconforming setback.
 - e. Extensions of nonconforming lot coverage.
 - f. Structural alterations to nonconforming residential density.

- g. Structural alterations to nonconforming buildings located on a property that also contains a lawful nonconforming use, whether or not that use occupies the subject building or structure.
2. **Parking.** Public safety structural alterations to a conforming or lawful nonconforming building or structure that reduce, relocate, or remove required parking spaces are permitted as follows:
 - a. Parking spaces may be converted to substandard compact spaces if approved by the Traffic Engineer.
 - b. Parking spaces may be relocated into a setback or other location by right to the extent necessary, as determined by the Zoning Officer, if:
 - i.* The requirements in Paragraph (a) above cannot be met.
 - ii.* The screening and landscaping requirements in Chapter 23.322 (Parking and Loading) are met.
 - iii.* The parking relocation is approved by the Traffic Engineer.
 - c. Required parking may be removed if the Traffic Engineer determines that the requirements of Paragraphs (a) and (b) above cannot be met.
 3. **Aesthetic Improvement or Screening.** Any aesthetic improvement or screening that the Zoning Officer determines is associated with a public safety structural alteration shall be treated as part of the public safety structural alteration.

B. Existing Public Libraries.

1. Notwithstanding any other provision in the Zoning Ordinance, a conforming or lawful nonconforming public library existing as of May 1, 2010 may be changed, expanded, or replaced by a new public library on the same site following demolition, subject to issuance of a Use Permit.
2. If the change, expansion, or new library is allowed by right under the Zoning Ordinance, a Use Permit is not required.
3. The ZAB may modify any requirement of the Zoning Ordinance applicable to such change, expansion, or new library as part of the Use Permit.

23.326 DEMOLITION AND DWELLING UNIT CONTROL

Sections:

- 23.326.010– Chapter Purpose
- 23.326.020– General Requirements
- 23.326.030– Eliminating Dwelling Units through Demolition
- 23.326.040– Eliminating Dwelling Units through Conversion and Change of Use
- 23.326.050– Private Right of Action
- 23.326.060– Elimination of Residential Hotel Rooms
- 23.326.070– Demolitions of Non-Residential Buildings
- 23.326.080– Building Relocations
- 23.326.090– Limitations

23.326.010 – Chapter Purpose

This chapter establishes demolition and dwelling unit control standards that promote the affordable housing, aesthetic, and safety goals of the City.

23.326.020 – General Requirements

- A. **Applicability.** No dwelling unit or units may be eliminated or demolished except as authorized by this chapter.
- B. **Findings.** In addition to the requirements below, the Zoning Adjustments Board (ZAB) may approve a Use Permit to eliminate or demolish a dwelling unit only upon finding that eliminating the dwelling unit would not be materially detrimental to the housing needs and public interest of the affected neighborhood and Berkeley.

23.326.030 – Eliminating Dwelling Units through Demolition

A. Buildings with Two or More Units Constructed Before June 1980.

- 1. **Applicability.** This subsection only applies to building with two or more units constructed before June 1980.
- 2. **Findings.** The ZAB may approve a Use Permit to demolish a building constructed before June 1980 on a property containing two or more dwelling units if any of the following are true:
 - a. The building containing the units is hazardous or unusable and is infeasible to repair.
 - b. The building containing the units will be moved to a different location within Berkeley with no net loss of units and no change in the affordability levels of the units.
 - c. The demolition is necessary to permit construction of special housing needs facilities such as, but not limited to, childcare centers and affordable housing developments that serve the greater good of the entire community.

- d. The demolition is necessary to permit construction approved pursuant to this chapter of at least the same number of dwelling units.

3. Fee Required.

- a. The applicant shall pay a fee for each unit demolished to mitigate the impact of the loss of affordable housing in Berkeley.
- b. The amount of the fee shall be set by resolution of the City Council.

c. In Lieu of a Fee.

- i.* In lieu of paying the impact fee, the applicant may provide a designated unit in the new project at a below market rate to a qualifying household in perpetuity.
- ii.* The affordability level of the below market rent and the income level of the qualifying household shall be set by resolution of the City Council.
- iii.* The applicant shall enter into a regulatory agreement with the City of Berkeley to provide the in lieu units.

4. Occupied Units.

a. Applicability.

- i.* The requirements in this subsection apply if units to be demolished are occupied.
- ii.* These requirements do not apply to tenants who move in after the application for demolition is submitted to the City if the owner informs each prospective tenant about the proposed demolition and that demolition constitutes good cause for eviction.

- b. **Notice.** The applicant shall provide all sitting tenants notice of the application to demolish the building no later than the date it is submitted to the City, including notice of their rights under Municipal Code Section 13.76 (Rent Stabilization and Eviction for Good Cause Program).

c. General Requirements.

- i.* The applicant shall provide assistance with moving expenses equivalent to in Chapter 13.84 (Relocation Services and Payments for Residential Tenant Households).
- ii.* The applicant shall subsidize the rent differential for a comparable replacement unit, in the same neighborhood if feasible, until new units are ready for occupancy. Funding for the rent differential shall be guaranteed in a manner approved by the City.

iii. Exception. An applicant who proposes to construct a 100 percent affordable housing project is not required to comply with this subsection but must comply with the Uniform Relocation Assistance and Real Property Acquisition Policies Act of 1970 as amended and the California Relocation Act (Government Code sections 7260 et seq.).

d. Sitting Tenants Rights.

- i.* Sitting tenants who are displaced as a result of demolition shall be provided the right of first refusal to move into the new building.
- ii.* Tenants of units that are demolished shall have the right of first refusal to rent new below-market rate units designated to replace the units that were demolished, at the rent that would have applied if they had remained in place, as long as their tenancy continues.

iii. Income restrictions do not apply to displaced tenants.

iv. Exception.

- 1. An applicant who proposes to construct a 100 percent affordable housing project is not required to comply with 23.326.030.A.4.a, b, and c, but must comply with the following requirement.
- 2. Sitting tenants who are displaced as a result of demolition and who desire to return to the newly constructed building will be granted a right of first refusal subject to their ability to meet income qualifications and other applicable eligibility requirements when the new units are ready for occupancy.

B. Buildings with a Single Dwelling Unit.

1. **Applicability.** This subsection only applies to buildings with a single dwelling unit.

2. **Limitations.**

a. Demolition is not allowed if:

- i.* The building was removed from the rental market under the Ellis Act during the preceding five years; or
- ii.* There have been verified cases of harassment or threatened or actual illegal eviction during the immediately preceding three years.

b. Where allegations of harassment or threatened or actual illegal eviction are in dispute, either party may request a hearing before a Rent Board Hearing Examiner. The Rent Board Hearing Examiner will provide an assessment of the evidence and all available documentation to the ZAB. The ZAB shall

determine whether harassment or threatened or actual illegal eviction occurred.

- C. **Accessory Buildings.** Notwithstanding anything in Municipal Code Title 23 (Zoning Ordinance) to the contrary, but subject to any applicable requirements in Municipal Code Section 3.24 (Landmarks Preservation Ordinance), accessory buildings of any size, including, but not limited to, garages, carports, and sheds, but not including any structure containing a lawfully established dwelling unit, which serves and is located on the same lot as a lawful residential use, may be demolished by right.

23.326.040 – Eliminating Dwelling Units through Conversion and Change of Use

- A. **General.** The ZAB may approve a Use Permit for the elimination of a dwelling unit in combination with another dwelling unit used for occupancy by a single household if it finds that:

1. The existing number of dwelling units exceeds maximum residential density in the district where the building is located; and
2. One of the following is true:
 - a. One of the affected dwelling units has been occupied by the applicant's household as its principal place of residence for no less than two years before the date of the application and none of the affected units are currently occupied by a tenant.
 - b. All of the affected dwelling units are being sold by an estate and the decedent occupied the units as their principal residence for no less than two years before the date of their death.

B. **Limitations.**

1. Demolition is not allowed if:
 - a. The building was removed from the rental market under the Ellis Act during the preceding five years; or
 - b. There have been verified cases of harassment or threatened or actual illegal eviction during the immediately preceding three years.
2. Where allegations of harassment or threatened or actual illegal eviction are in dispute, either party may request a hearing before a Rent Board Hearing Examiner. The Rent Board Hearing Examiner will provide an assessment of the evidence and all available documentation to the ZAB. The ZAB shall determine whether harassment or threatened or actual illegal eviction occurred.

C. **Effect of Noncompliance with the Two-Year Requirement.**

1. In a unit eliminated under Subsection A (General) is not occupied by the applicant's household for at least two consecutive years from the date of elimination, the affected unit must be restored to separate status.
2. This requirement shall be implemented by a condition of approval and a notice of limitation on the property, acceptable to the City of Berkeley.
3. The condition and notice will provide that if the owner's household does not occupy the unit for at least two years from the date of elimination the affected units must either be restored as separate dwelling units and the vacant unit(s) offered for rent within six months or the owner must pay a fee of \$75,000 in 2013 dollars, adjusted in May of each year according to the Consumer Price Index for the San Francisco Bay Area. The fee shall be deposited into the City of Berkeley's Housing Trust Fund.
4. The City of Berkeley may exempt an applicant from the two-year residency requirement if of an unforeseeable life change that requires relocation.

D. Effect of Eliminating a Dwelling Unit.

1. If eliminating a dwelling unit reduces the number of units in a building to four, the applicant shall record a notice of limitation against the subject property that the limitation on eviction of tenants under Chapter 13 (Public Peace, Morals and Welfare) shall continue to apply until:
 - a. The building is demolished; or
 - b. Sufficient units are added or restored such that the building contains at least five units.
2. The Zoning Officer may issue an AUP for a building conversion which eliminates a dwelling unit upon finding that the conversion will restore or bring the building closer to the original number of dwelling units that was present at the time it was first constructed, provided the conversion meets the requirements 23.326.040.A.1 and 2 and 23.326.040.B and C.

E. Exceptions.

1. The ZAB may approve a Use Permit for a change of use to a community care or a child care facility which eliminates a dwelling unit if it finds that such use is in conformance with the regulations of the district in which it is located.
2. The ZAB may approve a Use Permit to eliminate a dwelling unit through combination with another dwelling unit for the purpose of providing private bathrooms, kitchenettes, accessibility upgrades, and/or seismic safety upgrades to single-residential occupancy rooms in residential developments undergoing a publicly-funded rehabilitation.

3. Notwithstanding the general Use Permit requirement under 23.326.020 (General Requirements), a lawfully established accessory dwelling unit that is not a controlled rental unit may be eliminated with a Zoning Certificate if:
 - a. The re-conversion restores the original single-family use of the main building or lot; and
 - b. No tenant is evicted.

23.326.050 – Private Right of Action

Any affected tenant may bring a private action for injunctive and/or compensatory relief against any applicant and/or owner to prevent or remedy a violation of Sections 23.326.030 (Elimination of Dwelling Units through Demolition) and 23.326.040 (Elimination of Dwelling Units through Conversion and Change of Use). In any such action a prevailing plaintiff may recover reasonable attorney's fees.

23.326.060 – Elimination of Residential Hotel Rooms

- A. **General Requirements.** Before removal, the following requirements must be met for the ZAB to approve a Use Permit for the elimination of residential hotel rooms:
 1. The residential hotel owner shall provide or cause to be provided standard housing of at least comparable size and quality, at comparable rents and total monthly or weekly charges to each affected tenant
 2. One of the following three requirements shall be met:
 - a. The residential hotel rooms being removed are replaced by a common use facility, including, but not limited to, a shared kitchen, lounge, or recreation room, that will be available to and primarily of benefit to the existing residents of the residential hotel and that a majority of existing residents give their consent to the removal of the rooms.
 - b. Before the date on which the residential hotel rooms are removed, one-for-one replacement of each room to be removed is made, with a comparable room, in one of the methods set forth in this section.
 - c. Residential hotel rooms are removed because of building alterations related to seismic upgrade to the building or to improve access to meet the requirements of the American Disabilities Act (ADA).
- B. **Criteria for Replacement Rooms.** For purposes of this section, replacement rooms must be:
 1. Substantially comparable in size, location, quality, and amenities;

2. Subject to rent and eviction controls substantially equivalent to those provided by the Rent Stabilization Ordinance or those that applied to the original rooms which are being replaced; and
3. Available at comparable rents and total monthly or weekly charges to those being removed. Comparable rooms may be provided by:
 - a. Offering the existing tenants of the affected rooms the right of first refusal to occupy the replacement rooms;
 - b. Making available comparable rooms, which are not already classified as residential hotel rooms to replace each of the rooms to be removed; or
 - c. Paying to the City of Berkeley's Housing Trust Fund an amount sufficient to provide replacement rooms.
 - i. The amount to be paid to the City of Berkeley shall be the difference between the replacement cost, including land cost, for the rooms and the amount which the City of Berkeley can obtain by getting a mortgage on the anticipated rents from the newly constructed rooms.
 - ii. The calculations shall assume that rents in the newly constructed rooms shall not exceed the greater of either a level comparable to the weekly or monthly charges for the replaced rooms or the level which would be charged if no current tenant paid more than 30 percent of such tenant's gross income for rent.

C. Exception for Non-Profit Ownership. In a residential hotel owned and operated by a non-profit organization, recognized as tax-exempt by either the Franchise Tax Board and/or the Internal Revenue Service, residential hotel rooms may be changed to non-residential hotel room uses if the average number of residential hotel rooms per day in each calendar year is at least 95 percent of residential hotel rooms established for that particular residential hotel.

23.326.070 – Demolitions of Non-Residential Buildings

- A. Main Non-Residential Buildings.** A main building used for non-residential purposes may be demolished with a Use Permit.
- B. Accessory Buildings.**
 1. Demolishing an accessory building with less than 300 square feet of floor area is permitted as of right.
 2. An accessory building with 300 square feet or more of floor area may be demolished with an AUP.
- C. Landmarks Preservation Commission Review.**

1. Any application for a Use Permit or AUP to demolish a non-residential building or structure which is 40 or more years old shall be forwarded to the Landmarks Preservation Commission (LPC) for review before consideration of the Use Permit or AUP.
2. The LPC may initiate a landmark or structure-of-merit designation or may choose solely to forward to the ZAB its comments on the application.
3. The ZAB shall consider the recommendations of the LPC in when acting on the application.

D. **Findings.** A Use Permit or an AUP for demolition of a non-residential building or structure may be approved only if the ZAB or the Zoning Officer finds that:

1. The demolition will not be materially detrimental to the commercial needs and public interest of any affected neighborhood or the City of Berkeley; and
2. The demolition:
 - a. Is required to allow a proposed new building or other proposed new use;
 - b. Will remove a building which is unusable for activities which are compatible with the purposes of the district in which it is located or which is infeasible to modify for such uses;
 - c. Will remove a structure which represents an inhabitable attractive nuisance to the public; or
 - d. Is required for the furtherance of specific plans or projects sponsored by the City of Berkeley or other local district or authority upon a demonstration that it is infeasible to obtain prior or concurrent approval for the new construction or new use which is contemplated by such specific plans or projects and that adhering to such a requirement would threaten the viability of the plan or project.

23.326.080 – Building Relocations

A. **Treatment of Building Relocation.**

1. Relocating a building from a lot is considered a demolition for purposes of this chapter.
2. Relocating a building to a lot is considered new construction and is subject to all requirements applicable to new construction.
3. When a building is relocated to a different lot within in Berkeley, the lot from which the building is removed shall be known as the source lot and the lot on which the building is to be sited shall be known as the receiving lot. In such cases all notification requirements apply to both the source and receiving lots.

B. **Findings.** The ZAB may approve a Use Permit to relocate a building upon finding that:

1. The building to be relocated is not in conflict with the architectural character, or the building scale of the neighborhood or area to which it will be relocated; and
2. The receiving lot provides adequate separation of buildings, privacy, yards, and usable open space.

23.326.090 – Limitations

A. **Unsafe, Hazard, or Danger.**

1. Notwithstanding anything to the contrary, if a building or structure is unsafe, presents a public hazard, and is not securable and/or is in imminent danger of collapse so as to endanger persons or property, as determined by the city's building official, it may be demolished without a Use Permit.
2. The Building Official's determination in this matter shall be governed by the standards and criteria in the most recent edition of the California Building Code that is in effect in the City of Berkeley.

B. **Ellis Act.** This chapter shall be applied only to the extent permitted by state law as to buildings which have been entirely withdrawn from the rental market pursuant to the Ellis Act (California Government Code Chapter 12.75).

23.328 INCLUSIONARY HOUSING

Sections:

- 23.328.010– Chapter Purpose and Applicability
- 23.328.020– General Requirements
- 23.328.030– Payment of In-Lieu Fees as an Alternative to Providing Inclusionary Units
- 23.328.040– Requirements Applicable to All Inclusionary Units
- 23.328.050– Inclusionary Unit Requirements for Rental Housing Projects
- 23.328.060– Inclusionary Unit Requirements for Ownership Projects
- 23.328.070– Special Requirements for Avenues Plan Area
- 23.328.080– Administrative Regulations
- 23.328.090– Fees

23.328.010 – Chapter Purpose and Applicability

A. Purpose. The purpose of this chapter is to:

1. Promote Housing Element goals to develop affordable housing for households with incomes below the median, as defined in this chapter, or, in the case of limited equity cooperatives, households with incomes below 120 percent of the median.
2. Require the inclusion of affordable dwelling units in specified proposed developments (“projects”).

B. Applicability.

1. The following types of projects must comply with the inclusionary housing requirements of this chapter:
 - a. Residential housing projects constructing five or more dwelling units.
 - b. Residential housing projects constructing one to four new dwelling units when:
 - i.* Such units are added to an existing one to four-unit property developed after August 14, 1986; and
 - ii.* The resulting number of units totals five or more.
 - c. Residential housing projects proposed on lots with a size and zoning designation that allows construction of five or more dwelling units.
2. This chapter does not apply to dormitories, fraternity and sorority houses, boarding houses, residential hotels, or live/work units.
3. Live/work units are subject to low income inclusionary provisions in Section 23.312 (Live/Work).

4. This chapter sets forth specific inclusionary housing requirements for the Avenues Plan Area, which prevails over any conflicting requirements set forth elsewhere.

23.328.020 – General Requirements

A. Minimum Percent of Units.

1. Any project subject to this chapter is required to include at least 20 percent of the total number of dwelling units within the project as inclusionary units, except that limited equity cooperatives are required to include at least 51 percent of their units as inclusionary units.
2. In applying the percentages above, any decimal fraction above a whole number of dwelling units shall be paid as an in-lieu fee as stated in Section 23.328.040 (Requirements Applicable to All Inclusionary Units).

- B. Median Income Levels.** For the purpose of determining the median income levels for households under this chapter, the City shall use the Oakland Primary Metropolitan Statistical Area (PMSA) statistical figures that are available to the City from the most recent U.S. Census.

23.328.030 – Payment of In-Lieu Fees as an Alternative to Providing Inclusionary Units

A. Applicability.

1. As an alternative to providing inclusionary units required in an ownership project, the applicant may elect to enter in an agreement with the City to pay fees as set forth in this section in-lieu of providing units that are not required to be provided at below market prices pursuant to Government Code Section 65915.
2. This section applies to projects for which all required permits have already been issued, as long as no units within such a project have been sold.

- B. Deposit.** The fee shall be deposited in the City's Housing Trust Fund.

C. Fee Amount.

1. The in-lieu fee shall be 62.5 percent of the difference between the permitted sale price for inclusionary units and the amounts for which those units are actually sold by the applicant.
2. The fee shall be calculated and collected based on the sales prices of all of the units in a project to which the inclusionary requirement applies, such that the fee as charged shall be a percentage of the difference between the actual sales price for each unit, and the sales price that would have been permitted had that unit been an inclusionary unit.

3. The percentage shall be determined using the following formula: the number of units for which an in-lieu fee is substituted for an inclusionary unit divided by the total number of units to which the inclusionary ordinance applies, multiplied by 62.5 percent.
4. This fee shall only apply to units in a project that are counted in determining the required number of inclusionary units in a project and shall not apply to any units provided as a density bonus.
5. If the City Manager determines that an actual sales price does not reflect the fair market value of a unit, the City Manager shall propose an alternate price based on the fair market value of the unit.
6. If the developer and the City Manager cannot agree on a fair market value, the City Manager shall select an appraiser to prepare an appraisal of the unit and the appraised value shall be used as the market value.

D. Calculation of Inclusionary Sales Price.

1. The allowable inclusionary sales price for the purpose of calculating the in-lieu fee amount shall be three times 80 percent of the Area Median Income (AMI) last reported as of the closing date of the sale of the unit, with the exception that if the developer has already been authorized to charge an inclusionary sale price based on development costs pursuant to Ordinance 6,790-N.S. (adopted January 27, 2004, sunsetted February 19, 2006) the allowable inclusionary sale price for the purposes of this section shall be the price permitted under that ordinance.
2. Area median income (AMI) shall be calculated in accordance with the affordability regulations established by the City Manager pursuant to Section 23.328.080 (Administrative Regulations).

E. Time of Payment of Fee. The developer shall pay the in-lieu fee no later than the closing date of the sale of a unit as a condition of the closing.

23.328.040 – Requirements Applicable to All Inclusionary Units

A. Recipient Requirement.

1. All inclusionary units other than those in limited equity cooperatives shall be sold or rented to:
 - a. The City or its designee; or
 - b. Low income, lower income, or very low-income households.
2. Units in limited equity cooperatives shall be sold or rented to households whose gross incomes do not exceed 120 percent of the Oakland PMSA median.

- B. **Agreement.** The applicant shall execute a written agreement with the City indicating the number, type, location, approximate size, and construction schedule of all dwelling units and other information as required to determine compliance with this chapter.
- C. **Timing.** All inclusionary units in a project and phases of a project shall be constructed concurrently with, or before, the construction of non-inclusionary units.
- D. **Criteria.** All inclusionary units shall be:
1. Reasonably dispersed throughout the project;
 2. Of the same size and contain, on average, the same number of bedrooms as the non-inclusionary units in the project; and
 3. Comparable with the design or use of non-inclusionary units in terms of appearance, materials, and finish quality.
- E. **In-Lieu Fee Requirement.** In projects where calculating the inclusionary requirement results in a fraction of a unit, the fraction shall be paid in the form of an in-lieu fee to the City.
1. Where Government Code Section 65915 does not apply, the in-lieu fee shall be the fractional value of the difference between development cost (excluding marketing costs and profit) and actual sales price for the average comparable unit in projects.
 2. Where Government Code Section 65915 does apply, the in-lieu fee shall be the difference between affordable cost for an appropriately-sized household and the fractional value of the average comparable actual sales price for the fraction of the unit in projects to require a density bonus or equivalent incentive.
- F. **Use of In-Lieu Fees.**
1. The in-lieu fee shall be used by the City or its designee (such as a non-profit housing development corporation) to provide, construct, or promote the creation or retention of low-income housing in Berkeley.
 2. The use of in-lieu fees for specific housing programs shall be brought before the Housing Advisory and Appeals Board for review and approval.
- G. **Exceptions.** Where the applicant shows, and the City agrees, that the direct construction and financing costs of the inclusionary units, excluding marketing cost and profit (and also excluding land costs if a density bonus or equivalent incentive is provided), exceeds the sales prices allowed for inclusionary units by this chapter, the Zoning Adjustments Board (ZAB) may approve one or more of the following measures to reduce costs or increase profitability:

1. Reduce the floor area or the interior amenities of the inclusionary units, provided that such units conform to applicable building and housing codes.
2. Increase the number of bedrooms in the inclusionary units.
3. In a home ownership project, construct rental units in a number required to meet the inclusionary provisions of this chapter applicable to rental housing projects.
4. Waive the in-lieu fees for fractions of units.

23.328.050 – Inclusionary Unit Requirements for Rental Housing Projects

A. General Rental Requirements.

1. All inclusionary units shall be occupied by low, lower, or very low -income households.
2. The maximum rental price for inclusionary units shall be affordable to an appropriate-sized household whose income is 81 percent of the Oakland PMSA median.
3. In projects requiring more than one inclusionary unit, at least 50 percent of those units shall be rented at a price that is affordable to low or lower-income households, provided that the City can make available rental subsidies through the federal Section 8 Existing Housing Program or an equivalent program.
4. When there is an uneven number of inclusionary units, the majority of units shall be priced to be affordable to a household at 50 percent of median income if subsidies are available.
5. If no rental subsidies are available, all inclusionary unit prices shall be affordable to households at 81 percent income of the Oakland PMSA median.
6. If an applicant agrees to provide 10 percent lower income inclusionary units, the rental price for such units shall be affordable to a household with income that is 60 percent of the Oakland PMSA median.
7. Dwelling units designated as inclusionary units shall remain in conformance with the regulations of this section for the life of the building.
8. The City or its designee shall screen applicants for the inclusionary units and refer eligible households of the appropriate household size for the unit.
9. For purposes of occupancy, the appropriate household size standards used by the housing authority for the federal Section 8 Existing Housing Program or any future equivalent program shall be used.
10. The applicant or owner shall retain final discretion in the selection of the eligible households referred by the City.

11. The owner shall provide the City with data on vacancies and other information required to ensure the long-term affordability of the inclusionary units by eligible households.

B. Affordability Defined. A unit shall be considered affordable if the rent (including utilities) does not exceed 30 percent of a household's gross income.

1. Gross household income and utility allowance shall be calculated according to the guidelines used by the Berkeley Housing Authority for the federal Section 8 Existing Housing Program.
2. For purposes of calculating rent, appropriate household size shall be determined by using the schedule contained in the administrative regulations developed for this chapter.

23.328.060 – Inclusionary Unit Requirements for Ownership Projects

A. General Sale Requirements. Inclusionary units in ownership projects shall be sold as set forth below:

1. Inclusionary units in ownership projects shall be sold at a price that is affordable to an appropriate-sized household whose income is no more than 80 percent of the area median income reported for the Oakland PMSA for households of that size, unless the cost of development of the unit is greater than the affordable sales price.
2. Appropriate sizes of household and the ratio of income to sales price for affordable units shall be defined by City Manager regulation.
3. Inclusionary ownership units shall be affirmatively marketed to tenants with Section 8 housing vouchers, and who are known to be interested in participating in the Section 8 homeownership program, or other equivalent program(s) of the City, which are in effect at the time the units are offered for sale by the developer.

B. Right of First Refusal and Purchaser Preference.

1. The applicant for a project other than a limited equity housing cooperative is required to give right of first refusal to purchase any or all new inclusionary units to the City or a City designee for a period of not less than 60 days as evidenced by issuance of a certificate of occupancy.
2. Should the City choose not to exercise its right of first refusal, it shall provide the applicant or owner with a purchaser or with a list of eligible purchasers within a period of not less than 60 days.
 - a. If the list is not provided, the applicant may select a low-income purchaser of the applicant's choice as long as the City verifies income eligibility and the unit is sold at an affordable price as described in this chapter.

- b. The City shall maintain a list of eligible low-income households and review the assets and incomes of prospective purchasers of the inclusionary units on a project-by-project basis and refer potential purchasers to the applicant or owner.
 3. All purchasers of inclusionary units shall be first-time home buyers from low, lower, or very low-income households.
 4. Purchasers are also required to occupy the unit except that such requirement may be waived with the approval of the City. In such cases, the unit shall be rented to a low, lower, or very low-income household at a rent affordable by such households.
 5. Preference of inclusionary units are as follows:
 - a. First preference will be given to eligible Berkeley residents.
 - b. Second preference will be given to eligible persons employed in Berkeley.
 - c. Other preferences may also be established administratively, with Planning Commission review, to help meet the City's Housing Element goals.
 6. The City shall advise all prospective purchasers on the City's eligibility list of the resale restrictions applicable to ownership of inclusionary units and shall provide purchasers with a Declaration of Restrictions applicable to ownership of inclusionary units.
 7. Purchasers of inclusionary units in limited equity cooperatives at time of first occupancy shall be first time home buyers with gross incomes no greater than 120 percent of the Oakland PMSA median.
 8. Subsequent purchasers of inclusionary units in limited equity cooperatives shall be first time home buyers whose yearly gross income is no more than 44 percent of the cost of a unit at the time of sale, provided that such income is no more than 110 percent of the Oakland PMSA median.
- C. **Resale Restrictions.** All inclusionary units developed under this chapter except for those in limited equity cooperatives are subject to the resale restrictions set forth below.
1. Home ownership inclusionary units offered for sale or sold under the requirements of this chapter shall be offered to the City or its designee for a period of at least 60 days by the first purchaser or subsequent purchasers from the date of the owner's notification to the City of intent to sell.
 2. The resale price of the unit shall not exceed the original price and customary closing costs, except to allow for:

- a. The lower of any increase of either the Consumer Price Index (CPI) for all urban consumers (as produced by the U.S. Bureau of Labor Statistics or its successor agencies) applicable to the Oakland PMSA; or
 - b. The increase as measured in household income guidelines published annually by the U.S. Department of Housing and Urban Development (or its successor agencies) for the Oakland PMSA.
3. The resale formula shall supersede and replace the earlier resale formula in deed restrictions executed between February 19, 1987 (adoption date for Ordinance 5791-N.S.) and May 23, 2006.
 - a. The City, or its designee, shall notify each such owner of this change to the resale formula contained in their deed restriction within 60 days of adoption of this section.
 - b. All other terms and conditions of these deed restrictions shall remain in effect.
 4. If the City does not act on its right of first refusal, the same procedure for new inclusionary units shall be used for selection of a purchaser.
 5. The seller shall not levy or charge any additional fees nor shall any finders fee or other monetary consideration be allowed, other than customary real estate commissions if the services of a licensed real estate agent are employed.
 6. The City or its designee may monitor resale of inclusionary units in limited equity cooperatives.
 7. The City or its designee shall monitor the resale of ownership of inclusionary units.
 8. The owners of any inclusionary units shall attach, lawfully reference in the grant deed conveying title of any such inclusionary ownership unit, and record with the County Recorder a Declaration of Restrictions provided by the City, stating the restrictions imposed pursuant to this chapter. Violators of any of the terms may be prosecuted by the City.

23.328.070 – Special Requirements for Avenues Plan Area

A. City Council Findings. The City Council finds and determines that:

1. The Avenues Plan process identified several regional and Berkeley-specific barriers to housing development.
2. Among the Berkeley-specific barriers were:
 - a. High land prices;
 - b. Lengthy, difficult, and uncertain permit processes; and
 - c. Insufficient financing, especially for affordable housing projects.

3. The Avenues Plan area represents a core area of Berkeley where it is particularly appropriate to encourage housing development because of the area's generally good access to workplaces, transit service, senior services, and retail stores.
4. The policy to encourage housing in this area is reflected in several documents, including, but not limited to, the City's Housing Element of the General Plan, the Concept Plan for the General Plan revision, the Downtown Plan, the South Berkeley Area Plan, the West Berkeley Plan, and the University Avenue statement of planning of goals.
5. Despite the City's support for housing in this area, new housing development here has been limited and this has hindered revitalization of the area.
6. As part of a multi-pronged experimental strategy to create incentives to encourage housing development, relaxation of various inclusionary zoning requirements within the Avenues Plan area as set forth in this section is appropriate.
7. These changes will also assist the buyer of below market rate inclusionary units, by allowing buyers to gain greater appreciation on their investments (market conditions permitting), making the investment more similar to conventional home ownership, while retaining the long term affordability of inclusionary units.
8. The changes will also encourage the construction of larger family-sized units, rather than the smaller units which have generally been built in multi-family developments.
9. These changes in inclusionary zoning will be followed by mechanisms to make more financing available and changes in zoning standards and permit processes.
10. The success of these changes will be reviewed annually until the five-year time period of the Avenues Plan experiment expires July 1, 2000.

B. Applicability.

1. This section shall remain in effect until July 1, 2000, at which time the Planning Commission, in consultation with other relevant commissions, shall re-examine its effectiveness. At that time the Commission may initiate modifications to, or an extension of, this section.
2. This section applies on the streets and the addresses listed in Table 23.328-1. The area of applicability consists of the entire C-DMU District and portions of the C-C, C-U, C-SA, C-W, C-N, R-2A, R-3, and R-4 districts as indicated in the table. Within this area, this section supersedes any inconsistent provisions in this chapter.

TABLE 23.328-1: AVENUE AREAS PLAN AREA: STREET AND ADDRESS RANGE

| Street | Address |
|-----------------|--|
| Acton | 1940-2100 |
| Addison | 841-1145 odd, 1846 up |
| Adeline | All |
| Alcatraz Avenue | 1700-1937 |
| Allston Way | 1901-1999 odd, 2000 up |
| Ashby Avenue | 1830-2117, 2118-2198 even |
| Bancroft Way | 2000-2300 |
| Berkeley Square | All |
| Berkeley Way | 1200-1800 even only, 1800-1920, 1920-2000 even only, 2000 up |
| Blake | 1800-2100 |
| Bonar | 2000-2099 |
| Bonita | 1900-1950 even, 1950-1999 |
| Browning | portion of West Campus only |
| California | 1950-2009 |
| Carleton | 2000-2117 |
| Center | All |
| Channing Way | 1800-1850 even, 2000-2200, 2200-2300 odd |
| Cowper | All |
| Chestnut | 1910-1950 even, 1950 up |
| Curtis | 1900-2100, portion BUSD |
| Delaware | 1041-1112, 2000-2200 even |
| Derby | 2000-2113 |
| Dover | All |
| Durant Avenue | 2000-2300 |
| Dwight Way | 1800-1850 even, 1850-2200 |
| Ellis | 3124-3320 odd |
| Emerson | 2000-2111 |
| Essex | 1901-2106 |
| Fairview | 1750 up |

| Street | Address |
|----------------------------|--|
| Fulton | 2200-2400, 2400-2606 even |
| Grant | 1800-1900 odd, 1900-2050, 2501-2599 odd |
| Harold Way | All |
| Harmon | 1750 up |
| Harper | 2901-3123 odd |
| Haste | 1900-1998 even, 2000-2200 |
| Hearst | 1032-1200, 1800-2000 even, 2000-2200 |
| Henry | 1900 up |
| Jefferson Avenue | 2000-2050 |
| King | 3221 up, odd |
| Kittredge | All |
| Martin Luther King Jr. Way | 1900-2050, 2051-2199 odd, 2400-2450 even, 2450-2600, 2900 up |
| McGee Avenue | 1900-2050 |
| McKinley Avenue | 2400-2500 odd |
| Milvia | 1800-1950 odd, 1950-2199, 2200-2450 odd, 2450-2550, 2550-2900 odd only |
| Newbury | All |
| Oregon | 2000-2122 |
| Otis | All |
| Oxford | 1800-2200 |
| Parker | 1800-1998 even, 2000-2200 |
| Prince | 1830-2105 |
| Russell | 1820-2000 even, 2000-2117 |
| Sacramento | 1900-2000, 2050-2100 even |
| San Pablo Avenue | 1800-2199 |
| Shattuck Avenue | 1800 up |
| Shattuck Square | All |
| Stuart | 2100-2107 |
| Tremont | All |
| University Avenue | 840 up |

| Street | Address |
|---------|-----------|
| Walnut | 1800 up |
| West | 1950-1999 |
| Whitney | All |
| Woolsey | 1750-2110 |
| 6th | 1916-2099 |
| 7th | 1912-2099 |
| 8th | 1910-2099 |
| 9th | 1910-2099 |
| 10th | 1908-2099 |
| 62nd | 1700 up |
| 63rd | 1700 up |

C. Definitions. For purposes of this section, the following definitions apply:

1. "Project" means the total number of housing units planned to be built on a single lot or on a grouping of contiguous, commonly owned, or controlled lots, regardless of whether those units are all built simultaneously.
2. "Affordable family-sized unit" means a unit which:
 - a. Is at least 850 square feet in area if two bedrooms or 1,100 square feet if three bedrooms or more;
 - b. Contains at least two lawful bedrooms;
 - c. Contains at least as many bathrooms as the corresponding two-bedroom market rate units; and
 - d. Is sold at a price that is affordable to an appropriate sized household whose income is no more than 80 percent of the metropolitan area median as reported by the Department of Housing and Urban Development (HUD).

D. Number of Inclusionary Units Required.

1. The number of inclusionary units required are shown in the Table 23.328-2.

TABLE 23.328-2: NUMBER OF INCLUSIONARY UNITS REQUIRED

| Total Number of Units Built | Number of Required Inclusionary Units |
|-----------------------------|---------------------------------------|
| 10-14 | 1 |
| 15-19 | 2 |

| Total Number of Units Built | Number of Required Inclusionary Units |
|-------------------------------------|---------------------------------------|
| Each additional multiple of 5 units | 1 additional |

2. For every five units which the applicant can show with bona fide sales documents have been sold at a price at or below that affordable to an appropriately sized household with an income of 100 percent of metropolitan area median, the applicant is released of the obligation to provide one inclusionary unit.
3. For every 10 affordable family-sized units, the applicant is released of the obligation to provide one inclusionary unit sold at a price at or below that affordable to an appropriately sized household with an income of 100 percent of metropolitan area median.
4. Within the area of applicability for that portion of a project wherein both the inclusionary and the non-inclusionary units contain at least as many bathrooms as the corresponding two-bedroom market rate units, only 10 percent of units must be inclusionary.

E. Pricing Requirements.

1. The first inclusionary unit in projects with units for sale shall be sold at a price that is affordable to an appropriately sized household whose income is no more than 80 percent of the Oakland PMSA median as reported by HUD.
2. Except as otherwise provided in Section 23.328.070.C.2.d above, the second inclusionary unit shall be sold at a price that is affordable to an appropriate sized household whose income is no more than 100 percent of the PMSA median and subsequent inclusionary units shall be sold alternately at these price levels.
3. Inclusionary sale units in projects in the Avenues Plan Area shall be sold at a price such that first year housing cost (including homeowners' association dues, if any) for a household of appropriate size with an income at the targeted level shall not exceed 33 percent of income.
4. This cost shall be calculated assuming that the buyer makes a 10 percent down payment, which shall not be considered a portion of the cost.
5. The housing cost shall be calculated for each project at the time the condominium association budget is approved by the California Department of Real Estate and shall not be changed after that time for that project, regardless of future changes in cost.
6. The resale price of inclusionary units within the Avenues Plan Area may increase at the rate of increase of the Consumer Price Index for all urban consumers (CPI-U) applicable to the metropolitan area.

23.328.080 – Administrative Regulations

The City Manager or the City Manager's designee shall promulgate rules and regulations pertaining to this chapter, including but not limited to setting and administering gross rents and sale prices, requiring guarantees, entering into recorded agreements with applicants and taking other appropriate steps necessary to ensure that the required low income and very low income dwelling units are provided and occupied by low income households.

23.328.090 – Fees

The City Council, by resolution, may establish fees for the administration of this chapter.

23.330 DENSITY BONUS

Sections:

- 23.330.010– Chapter Purpose
- 23.330.020– Definitions
- 23.330.030– Application Requirements
- 23.330.040– Density Bonus Calculations and Procedures
- 23.330.050– Incentives and Concessions
- 23.330.060– Waivers and Reductions
- 23.330.070– Qualifying Units
- 23.330.080– Regulatory Agreements

23.330.010 – Chapter Purpose

The purpose of this chapter is to:

- A. Establish procedures and local standards to implement California Government Code Sections 65915–65918 consistent with local zoning regulations and development standards; and
- B. Provide special provisions consistent with the intent of State and local law. Unless otherwise noted, all section references in this chapter are to the California Government Code.

23.330.020 – Definitions

- A. **Terms Defined.** Terms used in this chapter are defined as follows:
 - 1. **Administrative Regulations.** Guidelines and procedures promulgated by the Planning Director that may be modified from time to time to effectively implement this ordinance.
 - 2. **Base Project.** The maximum allowable residential density on a housing development site pursuant to the applicable zoning district or, where no density standard is provided, as set forth in the Administrative Regulations before applying the density bonus.
 - 3. **Density Bonus.** Those residential units, floor area, rental beds or bedrooms added to the Base Project pursuant to the provisions of Government Code Section 65915 and this chapter.
 - 4. **Eligible Housing Development.** As defined in Government Code Section 65917.2.
 - 5. **Housing Development.** As defined in Government Code Section 65915(i).
 - 6. **Incentive and Concession.** An incentive or a concession as the terms are used in Government Code Section 65915 and in particular as defined in Section

65915(k) thereof. The City may request reasonable documentation from the applicant to support the request.

7. **Qualifying Unit.** A unit that is provided at a below market-rate rent or sales price as set forth in Government Code Section 65915 to receive a Density Bonus and/or Waivers and Reductions and/or Incentives and Concessions.
8. **Waiver and Reduction.** A waiver or a reduction as the terms are used in Government Code Section 65915 and in particular in Section 65915(e) thereof, and means any and all changes to or exemptions from physical lot development standards that are required to avoid precluding the construction of a Housing Development with Density Bonus Units, as set forth in Section 65915(e). The City may request reasonable documentation from the applicant to support the request.

B. **Terms Not Defined.** Terms not defined in this section shall be interpreted to give this chapter its most reasonable meaning and application, consistent with applicable state and federal law.

23.330.030 – Application Requirements

- A. **Required Information.** In addition to any other information required by the Zoning Ordinance, an application for a density bonus must include the following information:
 1. How the proposed project will satisfy the eligibility requirements of Section 65915 or 65917.2.
 2. For those districts without density standards, a density bonus schematic as set forth in the City of Berkeley Administrative Regulations.
 3. The requested density bonus pursuant to Municipal Code Section 23.330.040 (Density Bonus Calculations and Procedures).
 4. Any waivers and reductions that are sought under Section 65915.e that would be required to accommodate the housing development including the density bonus units.
 5. Any incentives and concessions that are sought under Section 65915.d accompanied by documentation of resulting cost reductions to provide for affordable housing costs.
 6. Any requested additional bonus units under Section 65915.n.
 7. Any requested parking reductions under Section 65915.p.
 8. Whether the applicant elects to receive a density bonus that is less than that mandated by Section 65915, including a density bonus of zero. In such cases, the applicant retains their entitlement to incentives and concessions.

9. Documentation of how a project complies with regulations regarding replacement units as described in Section 65915.c.3.

B. Documentation Supporting Requests. The City may request reasonable documentation from the applicant to support requested waivers/reductions and incentives/concessions.

23.330.040 – Density Bonus Calculations and Procedures

A. Calculation. Density bonuses must be calculated as set forth in Section 65915, 65917.2, and pursuant to the Administrative Regulations.

B. Procedures. Density bonus requests must accompany housing development permit applications and will be decided upon concurrent with the underlying permit for the project.

23.330.050 – Incentives and Concessions

A. Calculation. For purposes of this chapter, the number of incentives and concessions are counted as follows:

1. Any incentive and concession that would otherwise require discretionary approval by the Zoning Officer, the ZAB, or City Council of any single dimensional lot development standard, such as height or setbacks, or any single quantitative lot development standard, such as parking or open space, counts as one.
2. A proposed incentive and concession that would involve exceedance of a single physical lot development standard counts as one even if that exceedance would otherwise require more than one permit (e.g., extra height may require permits for height, floor area ratio, and/or number of stories but would count as one incentive and concession for height).
3. Where it is ambiguous as to whether a proposed incentive and concession involves one or more dimensional or quantitative lot development standards, the stricter interpretation applies, as determined by the review authority.

B. Procedural Requirements.

1. The City shall grant incentives and concession unless findings are made as set forth in Section 65915d.1.
2. The City is not required to deny a proposed incentive and concession solely because it can make a finding under Section 65915.d.1.
3. The City bears the burden of proof for the denial of a requested incentive and concession.

4. Unless denied under Section 65915, incentives and concessions are exempt from discretionary review of permits under the Zoning Ordinance, other than Design Review, and by law do not modify the CEQA review status of a project.

23.330.060 – Waivers and Reductions

- A. **Proposal.** An applicant may submit to the City a proposal for waivers and reductions of development standards that physically prevent construction of a housing development and density bonus units meeting the criteria of Section 65915.b.
- B. **Negotiated Process.** The City may negotiate changes to the requested waivers and reductions as part of the Use Permit and Design Review process, in coordination with the applicant, to address aspects of the project that may be of concern in the community or inconsistent with overarching principles of the General Plan, Zoning Ordinance, and Design Guidelines.
- C. **Denial.** The City may deny waivers and reductions for the reasons set forth in Section 65915.e.1.

23.330.070 – Qualifying Units

Qualifying units must meet the standards set forth in Section 23.328.040 (Requirements Applicable to All Inclusionary Units).

23.330.080 – Regulatory Agreements

Before issuance of a certificate of occupancy for a housing development that has received a density bonus, the applicant must enter into a regulatory agreement in a form provided by the City that implements Sections 65915–65918 and this chapter.

23.332 WIRELESS COMMUNICATION FACILITIES

Sections:

- 23.332.010– Chapter Purpose and Applicability
- 23.332.020– Definitions
- 23.332.030– General Requirements
- 23.332.040– Minimum Application Requirements
- 23.332.050– Location Requirements
- 23.332.060– Height Requirements
- 23.332.070– Design Requirements
- 23.332.080– Operation and Maintenance Standards
- 23.332.090– Public Information Requirements
- 23.332.100– Certification Requirements
- 23.332.110– Permits and Findings Required for Approval
- 23.332.120– Cessation of Operations

23.332.010 – Chapter Purpose and Applicability

A. Purpose. The purpose of this chapter is to:

1. Provide a uniform and comprehensive set of standards for the development, siting, installation, and operation of wireless telecommunications antennas and related facilities (“wireless telecommunications facilities”) for personal wireless services;
2. Foster an aesthetically pleasing urban environment, prevent visual blight, protect and preserve public safety and general welfare, and maintain the character of residential areas, including those adjacent to commercial areas and neighborhood commercial areas, consistent with the General Plan and adopted area plans and in compliance with applicable state and federal legislation; and
3. Prevent the location of wireless telecommunications facilities in Residential Districts unless:
 - a. The City is required to permit them in such locations to avoid violating the Telecommunications Act of 1996.
 - b. The wireless telecommunications facilities are designed to interfere as little as possible with the character of the neighborhood.
4. Establish and maintain telecommunications facilities that are components of a wireless telecommunications infrastructure designed to enhance the City’s emergency response network and not interfere with such emergency systems in violation of applicable federal or state regulations.
5. Establish a process for obtaining necessary permits for wireless telecommunication facilities that provides greater certainty to both applicants and

interested members of the public while ensuring compliance with all applicable zoning requirements.

6. Provide opportunities for further reduction in potential aesthetic or land use impacts of wireless telecommunications facilities as changes in technology occur.
7. Support the use of personal wireless services to enhance personal and public health and safety as well as the public welfare of Berkeley.

B. Applicability. The regulations in this chapter apply to all wireless telecommunications facilities for personal wireless services on property other than the public right-of-way in Berkeley.

23.332.020 – Definitions

A. Terms Defined. Terms used in this chapter are defined as follows:

1. **Antenna.** Any system of wires, poles, rods, panels, whips, cylinders, reflecting discs, or similar devices used for transmitting or receiving electromagnetic waves when such system is either external to or attached to the exterior of a structure, or is portable or movable. "Antenna" includes devices having active elements extending in any direction, and directional beam-type arrays having elements carried by and disposed from a generally horizontal boom that may be mounted upon and rotated through a vertical mast or tower interconnecting the boom and antenna support, all of which elements are deemed to be a part of the antenna.
2. **Antenna - Facade Mounted (also known as Building Mounted).** Any antenna, directly attached or affixed to the elevation of a building, tank, tower, or other structure.
3. **Antenna - Ground Mounted.** Any antenna with its base, whether consisting of single or multiple posts, placed directly on the ground or a single mast less than 15 feet tall and 6 inches in diameter.
4. **Antenna - Parabolic (also known as Satellite Dish Antenna).** Any device incorporating a reflective surface that is solid, open mesh, or bar configured that is shallow dish, cone, horn, bowl or cornucopia shaped and is used to transmit or receive electromagnetic or radio frequency communication/signals in a specific directional pattern.
5. **Approved Engineer.** Radio frequency engineer or licensed electrical engineer specializing in EMF or RFR studies approved by City of Berkeley staff to conduct analysis required pursuant to this chapter.
6. **Co-Location.** Location of any telecommunication facility owned or operated by a different telecommunication service provider on the same tower, building, or property.

7. **Personal Wireless Services.** Commercial mobile services, unlicensed wireless services, and common carrier wireless exchange access services as defined in the Telecommunications Act of 1996.
8. **Readily Visible.** A wireless telecommunications facility is readily visible if it can be seen from street level or from the main living area of a legal residence in a residential district or from a public park by a person with normal vision, and distinguished as an antenna or other component of a wireless telecommunication facility, due to the fact that it stands out as a prominent feature of the landscape, protrudes above or out from the building or structure ridgeline, or is otherwise not sufficiently camouflaged or designed to be compatible with the appurtenant architecture or building materials. For purposes of this definition, "main living area" means the living and dining and similar areas of a dwelling, but not bedrooms, bathrooms or similar areas.
9. **Stealth Facility.** Any wireless telecommunications facility that is not readily visible because it has been designed to blend into the surrounding environment and is visually unobtrusive. Examples may include architecturally screened roof-mounted antennas, building-mounted antennas that are painted and treated as architectural element to blend with the existing building, monopoles that are disguised as flag poles or public art, or camouflaged using existing vegetation. A pole or tower with antennas that are flush with or do not protrude above or out from the pole or antenna is not considered to be a stealth facility unless the pole or tower is an existing pole or tower, existing utility pole or tower, or existing light standard or street light, or replacement thereof.
10. **Structure Ridgeline.** The line along the top of an existing roof or top of a structure, including existing parapets, penthouses, or mechanical equipment screens.
11. **Telecommunications.** The transmission, between or among points specified by the user, of information of the user's choosing, without change in the content of the information as sent and received as defined in the Telecommunications Act of 1996.
12. **Telecommunications Equipment.** Equipment, other than customer premises equipment, used by a Telecommunications Carrier to provide Telecommunications Services, and includes software integral to such equipment (including upgrades) that is not located, in whole or in part, in, above, or below Streets, Public Rights- of-Way or other Public Property.
13. **Telecommunications Service.** The offering of telecommunications for a fee directly or indirectly to any Person as defined in the Telecommunications Act of 1996.
14. **Telecommunications Tower.** Any mast, pole, monopole, lattice tower, or other structure designed and primarily used to support antennas. A ground or building

mounted mast greater than 15 feet tall and 6 inches in diameter supporting one or more antennas, dishes, arrays, etc. shall be considered a telecommunications tower.

15. Wireless Telecommunications Facilities. Personal wireless service facilities as defined in the Telecommunications Act of 1996, including, but not limited to, facilities that transmit and/or receive electromagnetic signals for cellular radio telephone service, personal communications services, enhanced specialized mobile services, paging systems, and related technologies. Such facilities include antennas, microwave dishes, parabolic antennas, and all other types of equipment used in the transmission or reception of such signals; telecommunication towers or similar structures supporting said equipment; associated equipment cabinets and/or buildings; and all other accessory development used for the provision of personal wireless services. These facilities do not include radio towers, television towers, and government-operated public safety networks.

B. Terms Not Defined. Terms not defined in this section shall be interpreted to give this chapter its most reasonable meaning and application, consistent with applicable state and federal law.

23.332.030 – General Requirements

- A. In addition to any other requirements imposed by this chapter, all wireless telecommunications facilities on property other than the public right-of-way in Berkeley shall be consistent with the following:
- B. The General Plan, adopted area plans, and all other applicable provisions of the Zoning Ordinance.
- C. Applicable regulations and standards of any other governmental agency with jurisdiction over the installation or operation of wireless telecommunications facilities including, but not limited to, the Federal Communications Commission, the Federal Aviation Administration, and the California Public Utilities Commission.
- D. Any applicable discretionary permit affecting the subject property, except to the extent the Zoning Officer or Zoning Adjustments Board (ZAB) may modify such requirements.

23.332.040 – Minimum Application Requirements

- A. **Section Purpose.** This section establishes limited additional application submittal requirements for wireless telecommunications facilities. The purpose of these requirements is to ensure that the purposes of this chapter are implemented to the extent permitted by the Telecommunications Act of 1996.

B. Application Requirements. In addition to meeting the standard application submittal requirements for permits shown in Chapter 23.404 (Common Permit Requirements), wireless telecommunication facility applications required this chapter shall include the following information:

1. Coverage Map and General Information.

- a. A narrative description and map showing the coverage area of the provider's existing facilities that serve customers in Berkeley and the specific site that is the subject of the application.
- b. A statement of the telecommunications objectives sought for the proposed location, whether the proposed facility is necessary to prevent or fill a significant gap or capacity shortfall in the applicant's service area, whether it is the least intrusive means of doing so, and whether there are any alternative sites that would have fewer aesthetic impacts while providing comparable service.
- c. An AUP application need not include information as to whether the proposed facility is necessary to prevent or fill a significant gap or capacity shortfall in the applicant's service area.

2. Technical Information.

- a. Copies of or a sworn statement by an authorized representative that the applicant holds all applicable licenses or other approvals to construct the proposed facility required by the Federal Communications Commission (FCC), the California Public Utilities Commission (PUC), and any other agency of the Federal or State government with authority to regulate telecommunications facilities.
- b. Documentation of or a sworn statement by an authorized representative that the applicant is in compliance with all conditions imposed in conjunction with such licenses or approvals, a description of the number, type, power rating, frequency range, and dimensions of antennas, equipment cabinets, and related wireless telecommunications facilities proposed to be installed, and engineering calculations demonstrating that the proposed facility will comply with all applicable FCC requirements and standards.

3. Visibility.

- a. A site plan, plans, and elevations drawn to scale.
 - i. Plans shall include microcell, facade- or roof-mounted antennas, and all related equipment.
 - ii. Elevations shall include all structures on which facilities are proposed to be located.

- b. A description of the proposed approach for screening or camouflaging all facilities from public view including plans for installation and maintenance of landscaping, sample exterior materials, and colors, and an explanation of the measures by which the proposed facility will be camouflaged or made not readily visible.
- c. Where any part of the proposed facility would be readily visible, the application shall include an explanation as to why it cannot be screened from view.
- d. A visual impact analysis including scaled elevation diagrams within the context of the building, before and after photo simulations, and a map depicting where the photos were taken.
- e. The Zoning Officer may require the submission of photo overlays, scaled models, renderings, or mockups to document the effectiveness of techniques proposed to minimize visibility.
- f. If a ground-mounted or freestanding tower is proposed, the application must include an explanation as to why other facility types are not feasible.

4. Peer Review.

- a. The application shall include sufficient information for an approved radio frequency engineer or licensed electrical engineer specializing in EMF or RFR studies (“approved engineer”) retained by the City to peer review the information provided in response to Sections 23.322.040.B.2 and 3.
- b. The application shall include an agreement to pay the reasonable actual cost and a reasonable administrative fee for hiring an approved engineer to provide peer review.
- c. Any proprietary information disclosed to the City or its engineer in confidence shall not be a public record and shall remain confidential and not be disclosed to any third party without the express consent of the applicant.
- d. The City and/or its engineer shall return all proprietary information to the applicant and shall not retain any copies of such information once its decision is final.

5. Monitoring. An agreement to pay a reasonable one-time or annual fee for independent monitoring as required by this chapter.

6. Statement of Financial Assurances. A statement that before obtaining a building permit to erect or install the proposed facility, the applicant shall either secure a bond or provide financial assurances, in a form acceptable to the City Manager, for the removal of the facility if that its use is abandoned or the approval is otherwise terminated.

7. **Noise.** The Zoning Officer may require information concerning noise that might be generated by equipment associated with a wireless telecommunication facility, such as air conditioning equipment, if the physical circumstances of the proposed facility suggest that such noise may be detrimental.

23.332.050 – Location Requirements

- A. **Visibility.** A wireless communications facility may not be sited on or above a ridgeline or at any other location readily visible from a public park, unless ZAB makes the applicable findings required in Section 23.332.110.E (Findings).
- B. **Distance Between Freestanding Facilities.** A new freestanding facility, including towers, lattice towers, and monopoles, may not be located within 1,000 feet of another freestanding facility, unless appropriate stealth techniques have been used to minimize the visual impact of the facility to the extent feasible, and mounting on a building or co-location on an existing pole or tower is not feasible.

23.332.060 – Height Requirements

A. Measurement.

1. The height of a telecommunications tower is measured from existing grade below the center of the base of the tower to either:
 - a. The top of the tower; or
 - b. The tip of the highest antenna or piece of attached equipment if taller than the tower
2. The height of building-mounted antennas includes the height of that portion of the building on which the antenna is mounted.
3. In the case of “crank-up” or similar towers whose height is adjustable, the height of the tower is the maximum height to which it is capable of being raised.

B. Conformance with District Requirements.

1. No antenna telecommunications tower or facade-mounted antenna shall exceed or project above the height limits specified for the district in which the antenna is located.
2. Roof-mounted antennas affixed to an existing or proposed tower or pole shall not extend or project more than 15 feet above the height limit of the district.

23.332.070 – Design Requirements

In addition to all other requirements set forth in this chapter, all wireless telecommunication facilities shall meet the design requirements in this section.

A. **Order of Preference of Facility Type.** Based on potential aesthetic impact, the order of preference for facility type is as follows (ordered from most preferred to least preferred): microcell, facade-mounted, roof-mounted, ground-mounted, and freestanding tower.

B. **Visibility.**

1. All facilities shall be designed and located to minimize their visibility to the greatest extent feasible, considering technological requirements, by placement, screening, and camouflage.
2. The applicant shall use the smallest and least visible antennas feasible to accomplish the owner/operator's coverage or capacity objectives.
3. A wireless telecommunications facility that would be readily visible from the public right-of-way or from the habitable living areas of residential units within 100 feet of the facility shall incorporate appropriate techniques to camouflage or disguise the facility, and/or blend it into the surrounding environment, to the greatest extent feasible.
4. Facilities shall be compatible in scale and integrated architecturally with the design of surrounding buildings or the natural setting.

C. **Location.**

1. **View Corridor Impacts.** No readily visible antenna shall be placed at a location where it would impair a significant or sensitive view corridor except as provided for in Subsection (3) below.
2. **Facilities in Setbacks and Between Buildings and Rights-of-Way.** If telecommunications antenna or ancillary support equipment is located within any required setback or between the face of a building and a public right-of-way, permits are required as follows:
 - a. An AUP is required for microcell facilities and facilities that are completely subterranean.
 - b. A Use Permit is required for all other facilities.
3. **Roof- and Ground-Mounted Antennas.**
 - a. Roof-mounted antennas shall be located in an area of the roof where the visual impact is minimized.
 - b. Roof-mounted and ground-mounted antennas shall not be placed in direct line of sight of significant or sensitive view corridors or where they adversely affect scenic vistas unless the Zoning Officer or ZAB finds that the facility incorporates appropriate, creative stealth techniques to camouflage, disguise, and/or blend into the surrounding environment to the extent feasible.

- c. Roof mounted antennas shall be designed and sited to minimize their visibility and shall be no taller than necessary to meet the operator's service requirements.
- d. Where roof-mounted antennas are readily visible, confirmation of necessary height for service requirements, at the Zoning Officer's discretion, shall be based on independent analysis by an approved engineer retained by the City.

4. Satellite Dish or Parabolic Antennas.

- a. Satellite dish or parabolic antennas shall be situated as close to the ground as possible to reduce visual impact without compromising their function.
- b. When screened from pedestrian-level view from the public right-of-way and not readily visible from any property that contains a legally established residential use, satellite dish or parabolic antennas may be located in any required setback area subject to the approval of a Use Permit.
- c. No satellite dish or parabolic antenna may exceed 39 inches in diameter unless the Zoning Officer or ZAB finds that a smaller antenna cannot feasibly accomplish the provider's technical objectives and that the facility will not be readily visible. The Zoning Officer may require that this determination be based on independent technical analysis by an approved engineer.

5. Monopoles and Lattice Towers. All monopoles and lattice towers shall be designed to be the minimum functional height and width required to support the proposed antenna installation unless a higher monopole or lattice tower will facilitate co-location or other objectives of this chapter.

D. Colors and Materials.

- 1. Colors and materials for facilities shall be chosen to minimize visibility.
- 2. All visible exterior surfaces shall be constructed of non-reflective materials.
- 3. Facilities shall be painted or textured using colors to match or blend with the primary background.

E. Lighting.

- 1. Facility lighting shall be designed to meet but not exceed minimum requirements for security, safety, or FAA regulations, and in all instances shall be designed to avoid glare and minimize illumination on adjacent properties.
- 2. Lightning arresters and beacon lights shall not be included in the design of facilities unless required by the FAA.
- 3. Lightning arresters and beacons shall be included when calculating the height of facilities such as towers, lattice towers, and monopoles.

F. **Advertising.** No advertising shall be placed on telecommunications antennas or other equipment.

G. **Facility Design.**

1. All facilities shall be designed to be resistant to and minimize opportunities for unauthorized access, climbing, vandalism, graffiti, and other conditions that would result in hazardous conditions, visual blight, or attractive nuisances.
2. The Zoning Officer or ZAB may require the provision of warning signs, fencing, anti-climbing devices, or other techniques to prevent unauthorized access and vandalism when, because of their location and/or accessibility, antenna facilities have the potential to become an attractive nuisance.
3. The design of the fencing and other access control devices is subject to Design Review.

H. **Landscaping.**

1. Where appropriate and directly related to the applicant's placement, construction, or modification of wireless telecommunications facilities, the applicant shall maintain and enhance existing landscaping on the site, including trees, foliage and shrubs, when used for screening unless appropriate replacement landscaping is approved through the Design Review process.
2. Additional landscaping shall be planted as needed to minimize the visual impact of the facility and, when feasible, to block the line of sight between facilities and adjacent residential uses and properties in a residential district.
3. The appropriate minimum size of new trees and shrubs shall be approved through the Design Review process.

I. **Projection of Equipment.** Facade-mounted equipment, not including any required screening, shall not project more than 18 inches from the face of the building or other support structure unless specifically authorized by the Zoning Officer or ZAB.

J. **Ancillary Support Equipment.**

1. In order of preference, ancillary support equipment for facilities shall be located either within a building or structure, on a screened roof top area or structure, or in a rear yard if not readily visible from surrounding properties and the public right-of-way, unless the Zoning Officer or ZAB finds that another location is preferable under the circumstances of the application.
2. Above ground and partially buried ancillary equipment, including support pads, cabinets, shelters, and buildings, shall be located where they will be the least visible from surrounding properties and the public right-of-way. Such equipment shall be designed to be architecturally compatible with surrounding structures and/or screened using appropriate techniques to camouflage, disguise, and/or

blend into the environment including landscaping, color, and other techniques to minimize their visual impact.

3. If the Zoning Officer determines that an equipment cabinet is not or cannot be adequately screened from surrounding properties or from public view or architecturally treated to blend in with the environment, the equipment cabinet shall be placed underground or inside the existing building where the antenna is located unless the Zoning Officer or ZAB finds that such placement is not feasible or consistent with the objectives of this chapter and other applicable requirements.

K. Co-Located Antennas.

1. When antennas are co-located, the City may limit the number of antennas with related equipment and providers located on a site and adjacent sites to prevent negative visual impacts associated with multiple facilities.
2. Architectural and other camouflaging treatment shall be coordinated between all users on a site.

L. Parking. Proposed facilities shall not reduce the number of available parking spaces below the amount required by the Zoning Ordinance.

M. Effect of Modification. At the time of modification or upgrade of facilities, existing equipment shall, to the extent feasible, be replaced with equipment that reduces visual and noise impacts as feasible.

23.332.080 – Operation and Maintenance Standards

All wireless telecommunication facilities shall at all times comply with the following operation and maintenance standards. Failure to comply shall be considered a violation of conditions of approval subject to the enforcement provisions in this chapter.

A. Emergency Sign Required.

1. Each owner or operator of a wireless telecommunications facility shall provide signage identifying the name and phone number of a party to contact in event of an emergency.
2. The design, materials, colors, and location of signs is subject to Design Review.
3. Contact information must be kept current.

B. Maintenance and Repair.

1. Wireless telecommunications facilities and related equipment shall be maintained in good repair, free from trash, debris, litter, graffiti, and other forms of vandalism.
2. Damage from any cause shall be repaired as soon as reasonably possible so as to minimize occurrences of dangerous conditions or visual blight.

3. Graffiti shall be removed from any facility or equipment as soon as practicable, and in no instance more than 48 hours from the time of notification by the City.
4. Vehicle and personnel access to sites for maintenance and repairs shall not be from residential streets or adjacent residential properties to the maximum extent feasible.

C. Landscaping.

1. The owner or operator of a wireless telecommunications facility shall be responsible for maintaining landscaping in accordance with the approved landscape plan and for replacing any damaged or dead trees, foliage, or other landscaping elements shown on the approved plan.
2. Amendments or modifications to the landscape plan must be submitted to the Zoning Officer for approval.

D. Operation Standards.

1. Each wireless telecommunications facility shall be operated in a manner that will minimize noise impacts to surrounding residents and persons using nearby parks, trails, and similar recreation areas.
2. Except for emergency repairs, testing and maintenance activities that will be audible beyond the property line shall only occur between the hours of 8:00 a.m. and 7:00 p.m. on Monday through Friday, excluding holidays.
3. All air conditioning units and any other equipment that may emit noise audible from beyond the property line shall be enclosed or equipped with noise attenuation devices to the extent necessary to ensure compliance with applicable noise limitations under Chapter 13.40 (Community Noise).
4. Backup generators shall only be operated during periods of power outages or for testing.
5. At no time shall equipment noise from any source exceed the standards shown in Chapter 13.40 (Community Noise).

E. Facilities Providing Service to the Government or General Public. All wireless telecommunications facilities providing service to the government or the general public shall be designed to meet the following requirements:

1. The exterior walls and roof covering of all above ground equipment shelters and cabinets shall be constructed of materials rated as nonflammable.
2. Openings in all above ground equipment shelters and cabinets shall be protected against penetration by fire and windblown embers to the greatest extent feasible.
3. Material used as supports for antennas shall be fire resistant, termite proof, and comply with all applicable regulations.

4. Telecommunications antenna towers shall be designed to withstand forces expected during earthquakes to the extent feasible.
 - a. Building-mounted facilities shall be anchored so that an earthquake does not dislodge them or tip them over.
 - b. All equipment mounting racks and attached equipment shall be anchored so that an earthquake would not tip them over, throw equipment off their shelves, or otherwise damage equipment.
 - c. All connections between various components of the wireless telecommunications facility and necessary power and telephone lines shall, to the greatest extent feasible, be protected against damage by fire, flooding, and earthquake.
5. Reasonable measures shall be taken to keep wireless telecommunication facilities in operation in the event of a natural disaster.

23.332.090 – Public Information Requirements

- A. **Map and Inventory.** The Planning and Development Department shall maintain a map and inventory of all existing and proposed wireless telecommunication sites, which shall be available to members of the public and other interested parties for inspection.
- B. **Inventory Information.** The inventory shall, at a minimum, include the following information:
 1. Address of site.
 2. Number, type, power rating, and frequency range of all antennas at the site.
 3. Name of telecommunications carrier owning, operating, or leasing each antenna at the site.
 4. Date of most recent certification.

23.332.100 – Certification Requirements

- A. **General.**
 1. No wireless telecommunications facility or combination of facilities shall at any time produce power densities that exceed the FCC's limits for electric and magnetic field strength and power density for transmitters.
 2. To ensure continuing compliance with all applicable emission standards, all wireless telecommunications facilities shall submit reports as required by this section.

3. The City may require, at the operator's expense, independent verification of the results of any analysis.
4. If an operator of a telecommunications facility fails to supply the required reports or fails to correct a violation of the FCC standard following notification, the Use Permit or AUP is subject to modification or revocation by the ZAB following a public hearing.

B. All Facilities.

1. Within 45 days of initial operation or modification of a telecommunications facility, the operator of each telecommunications antenna shall submit to the Zoning Officer written certification by a licensed professional engineer that the facility's radio frequency emissions are in compliance with the approved application and any required conditions.
 - a. The engineer shall measure the radio frequency radiation of the approved facility, including the cumulative impact from other nearby facilities, and determine if it meets the FCC requirements.
 - b. A report of these measurements and the engineer's findings with respect to compliance with the FCC's Maximum Permissible Exposure (MPE) limits shall be submitted to the Zoning Officer.
 - c. If the report shows that the facility does not comply with applicable FCC requirements, the owner or operator shall cease operation of the facility until the facility complies with, or has been modified to comply with, this standard.
 - d. Proof of compliance shall be a certification provided by the engineer who prepared the original report.
 - e. The City may require, at the applicant's expense, independent verification of the results of the analysis.
2. Before January 31 of every year, an authorized representative for each wireless carrier providing service in the City shall provide written certification to the City that each facility is being operated in accordance with the approved local and federal permits and shall provide the current contact information.
3. Once every two years, at the operator's expense, the City may conduct or retain an approved engineer to conduct an unannounced spot check of the facility's compliance with applicable FCC radio frequency standards.
4. If there is a change in the FCC's MPE limits for electric and magnetic field strength and power density for transmitters, the operator of each wireless telecommunications facility shall submit to the Zoning Officer written certification by a licensed professional engineer of compliance with applicable FCC radio frequency standards within 90 days of any change in applicable FCC radio

frequency standards or of any modification of the facility requiring a new submission to the FCC to determine compliance with emission standards.

5. If calculated levels exceed 50 percent of the FCC's MPE limits, the operator of the facility shall hire an approved engineer to measure the actual exposure levels.
6. If calculated levels are not in compliance with the FCC's MPE limit, the operator shall cease operation of the facility until the facility is brought into compliance with the FCC's standards and all other applicable requirements.
7. A report of these calculations, required measurements, if any, and the engineer's findings with respect to compliance with the current MPE limits shall be submitted to the Zoning Officer.
8. If the Zoning Officer at any time finds that there is good cause to believe that a telecommunications antenna does not comply with applicable FCC radio frequency standards, the Zoning Officer may require the operator to submit written certification that the facility is in compliance with such FCC standards.

C. Facilities Approved Before 2002.

1. The owner or operator of a wireless telecommunications facility that was approved by the City before January 17, 2002, shall submit to the Zoning Officer, within six months from the date of notification, written certification by an engineer that the facility's radio frequency emissions are in compliance with the approved application and any required conditions.
2. The engineer shall measure the radio frequency radiation of the approved facility, including cumulative impact from other nearby facilities, and determine if it meets the FCC requirements.
3. If the report shows that the facility does not comply with applicable FCC requirements, the owner or operator shall cease operation of the facility until the facility is brought into compliance.
4. To ensure the objectivity of the analysis, the City may require, at the applicant's expense, independent verification of the results of the analysis.

D. Nonconformities.

1. Any facility that was approved by the City before January 17, 2002, and which does not comply with this chapter on the date of its adoption shall be considered a lawful nonconforming use; provided, that the owner or operator submits the information required in 23.332.100.C (Facilities Approved Before 2002).
2. Roof-mounted or facade-mounted antennas proposed on an existing building, tower, or pole that is legal nonconforming in terms of height shall not extend or project more than 15 feet above the existing height of the building or structure.

3. A lawful nonconforming personal wireless service facility is subject to the requirements of 23.324 (Nonconforming Uses, Structures, and Buildings) except to the extent that they are modified as allowed by this chapter.

E. Violations.

1. Failure to submit the information required in this section is considered a violation of the Zoning Ordinance.
2. Any facility found in violation may be ordered to terminate operations by the ZAB following a duly noticed public hearing.

23.332.110 – Permits and Findings Required for Approval

A. Permit Required.

1. All wireless telecommunications facilities in any district that require a Use Permit or an AUP are subject to the permit findings in this section and Chapter 23.406 (Specific Permit Requirements).
2. Required findings in Chapter 23.406—Specific Permit Requirements shall not be based on aesthetic impacts if the proposed facility would not be readily visible, or on any other matter that the City is prohibited from considering by the Telecommunications Act of 1996.

B. Modifications. The Zoning Officer may approve minor modifications and aesthetic upgrades that do not increase the size or visibility of any legally established wireless telecommunication facilities without notice or hearing, subject to compliance with all existing conditions of approval.

C. Administrative Use Permit. The following wireless telecommunications facilities require an AUP:

1. Microcell facilities in any district.
2. Modifications to existing sites in Non-Residential Districts.
3. Additions to existing sites in Non-Residential Districts when the site is not adjacent to a Residential District.
4. All new or modified wireless communication facilities in Manufacturing Districts.

D. Use Permit. All new or modified wireless telecommunications facilities not listed in Subsection C (Administrative Use Permit) above require a Use Permit except when otherwise required by Section Chapter 23.404.070– Permit Modifications or this chapter.

E. Findings. The ZAB or Zoning Officer may approve a Use Permit or AUP under this chapter only if it makes all of the following findings:

1. The proposed project is consistent with the general requirements of this chapter and any specific requirements applicable to the proposed facility.
 2. The proposed antenna or related facility, operating alone and in conjunction with other telecommunications facilities, will comply with all applicable state and federal standards and requirements.
 3. One of the following is true:
 - a. The proposed facility is not readily visible.
 - b. It is infeasible to incorporate additional measures that would make the facility not readily visible.
 4. Except for microcell facilities, the facility is necessary to prevent or fill a significant gap in coverage or capacity shortfall in the applicant's service area and is the least intrusive means of doing so.
 5. The wireless carrier complies with Paragraphs (1) and (2) of Subsection 23.332.090.B (All Facilities). If a wireless carrier has not complied with those sections, the wireless carrier may become compliant by providing current contact information and certification statements for any sites which are not current.
- F. **Basis for Findings.** All findings must be based on substantial information in the record such as, where required, technical analysis by an approved radio frequency engineer, calculations by a state-licensed structural engineer, or other evidence.

23.332.120 – Cessation of Operations

- A. **General.** Within 30 days of cessation of operations of any wireless telecommunications facility approved pursuant to this chapter, the operator shall notify the Zoning Officer in writing.
- B. **Lapse of Permit.** The wireless telecommunications facility permit shall be deemed lapsed and of no further effect six months thereafter unless one of the following is true.
 1. The Zoning Officer has determined that the same operator resumed operation within six months of the notice.
 2. The City has received an application to transfer the permit to another operator.
- C. **Effect of Lapse.**
 1. No later than 30 days after a permit has lapsed, the operator shall remove all wireless telecommunication facilities from the site.
 2. If the operator fails to do so, the property owner shall be responsible for removal, and may use any bond or other assurances provided by the operator pursuant to the requirements of Section 23.332.050– Location Requirements to do so.

3. If such facilities are not removed, the site shall be deemed to be a nuisance pursuant to Chapter 23.414—Nuisance Abatement and the City may call the bond to pay for removal.

D. **Failure to Inform.** Failure to inform the Zoning Officer of cessation of operations of any existing facility constitutes a violation of the Zoning Ordinance and shall be grounds for any or all of the following:

1. Prosecution.
2. Revocation or modification of the permit.
3. Calling of any bond or other assurance secured by the operator pursuant to the requirements of Section 23.332.050— Location Requirements.
4. Removal of the facilities.

E. **Transfer of Ownership.**

1. Any FCC-licensed telecommunications carrier that is buying, leasing, or considering a transfer of ownership of an already approved facility, shall provide written notification to the Zoning Officer and request transfer of the existing Use Permit.
2. The Zoning Officer may require submission of any supporting materials or documentation necessary to determine that the proposed use is in compliance with the existing Use Permit and all of its conditions including, but not limited to, statements, photographs, plans, drawings, models, and analysis by a state-licensed radio frequency engineer demonstrating compliance with all applicable regulations and standards of the FCC and the California PUC.
3. If the Zoning Officer determines that the proposed operation is not consistent with the existing Use Permit, they shall notify the applicant who may revise the application or apply for modification to the Use Permit pursuant to the requirements of Chapter 23.404—Common Permit Requirements.

23.334 TRANSPORTATION DEMAND MANAGEMENT

Sections:

23.334.010– Chapter Purpose

23.334.020– Applicability

23.334.030– Transportation Demand Management Program Requirements

23.334.040– Monitoring, Reporting and Compliance

23.334.010 – Chapter Purpose

- A. **Purpose.** The purpose of this chapter is to establish a Transportation Demand Management (TDM) Program that supports:
1. Transportation Element goals to reduce vehicle trips, encourage public transit use and promote bicycle and pedestrian safety, and
 2. Climate Action Plan goals to reduce private vehicle travel and promote mode shift to more sustainable transportation options.

23.334.020 – Applicability

A. **Applicability.**

1. The requirements of this chapter apply to residential projects with ten or more units, including residential portions of mixed-use projects.
2. For projects that add ten or more units to an existing building or property, the requirements of this chapter apply to all of the units (existing and new) on the property.
3. The following types of projects are exempt from the requirements of this chapter:
 - a. Projects for which a building permit was issued before March 19, 2021.
 - b. Residential projects, including the residential portion of mixed-use projects or projects that add units to an existing building or property, in the C-DMU district;
 - c. Residential projects, including the residential portion of mixed-use projects, with the majority of the units subject to recorded affordability restrictions. If added to an existing building or property, the entire building or property is exempt.
4. Projects in the Southside Plan area are exempt from the transit benefit requirements in Section 23.334.030.B– Transportation Demand Management Program Requirements (Transit Benefit).

23.334.030 – Transportation Demand Management Program Requirements

- A. **Unbundled Parking.** Parking spaces provided for residents shall be leased or sold separate from the rental or purchase of dwelling units for the life of the dwelling units.
- B. **Transit Benefit.**
 - 1. At least one of the following transit benefits shall be offered, at no cost, to project residents for a period of ten years after the issuance of a Certificate of Occupancy.
 - a. A monthly pass for unlimited local bus transit service; or
 - b. A functionally equivalent transit benefit in an amount at least equal to the price of a non-discounted unlimited monthly local bus pass. Any benefit proposed as a functionally equivalent transportation benefit shall be approved by the Zoning Officer in consultation with the Transportation Division Manager.
 - 2. For projects that include 99 dwelling units or fewer, the project shall provide one transit benefit per bedroom, up to a maximum of two benefits per dwelling unit. For projects of 100 dwelling units or more, the project shall provide one transit benefit for every bedroom in each dwelling unit.
 - 3. A notice describing these transportation benefits shall be posted in a location or locations visible to residents.
- C. **Real-Time Transportation Information.** Any project subject to this chapter shall provide publicly-available, real-time transportation information in a common area, such as a lobby or elevator bay, on televisions, computer monitors or other displays readily visible to residents and/or visitors. Provided information shall include, but is not limited to, transit arrivals and departures for nearby transit routes.

23.334.040 – Monitoring, Reporting and Compliance

- A. **Site Inspection Before Certificate of Occupancy.** For projects subject to this chapter, before issuance of a Certificate of Occupancy, the property owner shall facilitate a site inspection by Planning Department staff to confirm that the physical improvements required in Section 23.334.030.C– Transportation Demand Management Program Requirements (Real-Time Transportation Information) and 23.322.090– Bicycle Parking have been installed. The property owner shall also provide documentation that the programmatic measures required in 23.334.030.A (Unbundled Parking) and 23.334.030.B (Transit Benefit) will be implemented.
- B. **Regular TDM Compliance Reporting.** The property owner shall submit to the Planning Department TDM Compliance Reports in accordance with Administrative

Regulations promulgated by the Zoning Officer that may be modified from time to time to effectively implement this chapter.

- C. **Administrative Fees.** Property owners may be required to pay administrative fees associated with compliance with this chapter as set forth in the City's Land Use Planning Fees schedule.

DIVISION 4: PERMITS AND ADMINISTRATION

23.402: Administrative Responsibility

- 23.402.010– Purpose
- 23.402.020– Review and Decision-Making Authority
- 23.402.030– Planning and Development Department
- 23.402.040– Zoning Officer
- 23.402.050– Landmarks Preservation Commission
- 23.402.060– Design Review Committee
- 23.402.070– Zoning Adjustments Board
- 23.402.080– Planning Commission
- 23.402.090– City Council

23.404: Common Permit Requirements

- 23.404.010– Purpose and Applicability
- 23.404.020– Application Submittal
- 23.404.030– Application Review
- 23.404.040– Public Notice
- 23.404.050– Public Hearings and Decisions
- 23.404.060– Post-Decision Provisions
- 23.404.070– Permit Modifications
- 23.404.080– Permit Revocation

23.406: Specific Permit Requirements

- 23.406.010– Purpose
- 23.406.020– Zoning Certificates
- 23.406.030– Administrative Use Permits
- 23.406.040– Use Permits
- 23.406.050– Variances
- 23.406.060– Master Use Permits
- 23.406.070– Design Review
- 23.406.080– Modification of Development Standards in West Berkeley Plan Area
- 23.406.090– Reasonable Accommodations

23.408: Green Pathway

- 23.408.010– Purpose
- 23.408.020– Applicability
- 23.408.030– Eligibility Determination
- 23.408.040– Green Pathway Application

- 23.408.050– General Requirements
- 23.408.060– Requirements for Large Buildings and Hotels
- 23.408.070– Development Standards
- 23.408.080– Streamlined Permitting Process
- 23.408.090– Tolling
- 23.408.100– Compliance
- 23.408.110– City Manager Authority to Issue Regulations

23.410: Appeals and Certification

- 23.410.010– Chapter Purpose
- 23.410.020– Appeal Subjects and Jurisdiction
- 23.410.030– Filing and Processing of Appeals
- 23.410.040– Hearing and Decision
- 23.410.050– City Council Certifications

23.412: Zoning Ordinance Amendments

- 23.412.010– Purpose
- 23.412.020– Initiation
- 23.412.030– Application
- 23.412.040– Planning Commission Hearing and Action
- 23.412.050– City Council Hearing and Action
- 23.412.060– Findings for Approval
- 23.412.070– Limitations on Resubmittals after Denial
- 23.412.080– Zoning Map Amendment Notations

23.414: Nuisance Abatement

- 23.414.010– Purpose
- 23.414.020– Enforcement Responsibility
- 23.414.030– Violations a Misdemeanor
- 23.414.040– Nuisances Prohibited
- 23.414.050– City Attorney Action
- 23.414.060– Abatement Procedures
- 23.414.070– Statements of Violations
- 23.414.080– Remedies
- 23.414.090– Recovery of Costs
- 23.414.100– Private Right of Action

23.402 ADMINISTRATIVE RESPONSIBILITY

Sections:

- 23.402.010– Purpose
- 23.402.020– Review and Decision-Making Authority
- 23.402.030– Planning and Development Department
- 23.402.040– Zoning Officer
- 23.402.050– Landmarks Preservation Commission
- 23.402.060– Design Review Committee
- 23.402.070– Zoning Adjustments Board
- 23.402.080– Planning Commission
- 23.402.090– City Council

23.402.010 – Purpose

This chapter describes City roles and responsibilities when administrating the Zoning Ordinance.

23.402.020 – Review and Decision-Making Authority

- A. **Summary Table.** Table 23.402-1 summarizes the review and decision-making authority when processing permit applications and other requested approvals.
- B. **Meaning of Notations.** Authority roles as noted in Table 23.402-1 mean the following:
 - 1. “Recommend” means the authority reviews and makes a recommendation to a higher decision-making body.
 - 2. “Decision” means the authority has the power to approve, conditionally approve, or deny an application.
 - 3. “Appeal” means the authority has the power to hear an appeal of a decision by a lower review authority.
 - 4. “–” means the authority role has no role in the application.

TABLE 23.402-1: REVIEW AND DECISION-MAKING AUTHORITY

| Type of Action | Zoning Ordinance Location | Planning and Development Department | Role of Authority | | | | | |
|---|---------------------------|-------------------------------------|-------------------|---|--|--------------------------|---------------------|--------------|
| | | | Zoning Officer | Design Review Committee | <u>Landmarks Preservation Commission</u> | Zoning Adjustments Board | Planning Commission | City Council |
| Legislative Actions | | | | | | | | |
| Zoning Ordinance Amendments | 23.412 | Recommend | – | – | | – | Recommend | Decision |
| Permits | | | | | | | | |
| Administrative Use Permits | 23.406.030 | – | Decision | – | | Appeal | – | Appeal |
| Use Permits | 23.406.040 | Recommend | – | – | | Decision | – | Appeal |
| Master Use Permits | 23.406.060 | Recommend | – | – | | Decision | – | Appeal |
| Design Review | | | | | | | | |
| Design Review | 23.406.070 | Recommend | – | Decision [1] <u>See Note [1]</u> | | Appeal | – | Appeal |
| Staff-Level Design Review | 23.406.070 | – | Decision | Appeal | | Appeal | – | Appeal |
| Flexibility and Relief | | | | | | | | |
| Variances | 23.406.050 | Recommend | | – | | Decision | – | Appeal |
| Modifications to Development Standards in West Berkeley | 23.406.080 | Recommend | – | – | | Decision | – | Appeal |

| | | | | | | | | |
|---|------------|---|----------|---|--------------|---|---|--------|
| Plan Area | | | | | | | | |
| Reasonable Accommodations | 23.406.090 | - | - | | See Note [2] | | - | Appeal |
| Ministerial Actions | | | | | | | | |
| Zoning Certificates | 23.406.020 | - | Decision | - | | - | - | - |
| <p>Note:</p> <p>[1] Landmarks Preservation Commission <u>conducts Design Review approval required</u> for projects that involve landmarks, structures of merit or buildings within a historic district. <u>Design Review Committee conducts design review for all other project.</u></p> <p>[2] Either the Zoning Officer or Zoning Adjustments Board takes action on reasonable accommodation applications as described in Section 23.406.090.C.</p> | | | | | | | | |

- C. **Multiple Permit Applications.** For projects that include multiple permits, see 23.404.020.F– Application Submittal (Multiple Permit Applications).

23.402.030 – Planning and Development Department

The Planning and Development Department:

- A. Makes recommendations on requested permits and approvals as shown in Table 23.402-1: Review and Decision-Making Authority.
- B. Processes permit applications as provided in 23.404—Common Permit Requirements;
- C. Assumes responsibilities delegated by the Planning and Development Director and Zoning Officer; and
- D. Performs other duties as necessary to administer the Zoning Ordinance.

23.402.040 – Zoning Officer

- A. **Established.** The City Manager shall designate a Planning and Development Department employee to act as the Zoning Officer.
- B. **Responsibilities and Powers Duties.**
 - 1. **The Zoning Officer:**
 - a. Acts as the Secretary to the Zoning Adjustments Board (ZAB) and the Design Review Committee (DRC);
 - b. Determines if land uses, structures, and activities conform with the Zoning Ordinance;
 - c. Serves as the review authority on applications as shown in Table 23.402-1: Review and Decision-Making Authority;
 - d. Has the authority to interpret the meaning and applicability of the Zoning Ordinance;
 - e. Enforces the Zoning Ordinance in accordance with Chapter 23.414—Nuisance Abatement;
 - f. Issues administrative regulations and procedures for the administration of the Zoning Ordinance;
 - g. Refers persons to a conflict resolution or mediation service in accordance with Section 23.404.050.K– Public Hearings and Decisions (Use of Conflict Resolution and Mediation Service);
 - h. Requests legal opinions from the City Attorney on legal questions regarding pending applications; and

- i. Performs other duties to administer the Zoning Ordinance as assigned by the ~~ZAB, Planning Commission, and~~ City Council.
- 2. The Zoning Officer may designate one or more Planning and Development Department staff to perform the duties described in Paragraph (1) above.
- C. **Duties as Secretary to ZAB and DRC.** As Secretary to the ZAB and DRC, the Zoning Officer or the Zoning Officer's designee shall:
 - 1. Present to the ZAB and DRC applications for permits and other requested approvals;
 - 2. Prepare staff reports on applications;
 - 3. Advise the ZAB and DRC on the meaning and applicability of the Zoning Ordinance; and
 - 4. Transmit to the City Attorney requests for legal opinions on pending applications.

23.402.050 – Landmarks Preservation Commission

- A. ~~**Design Review.** The Landmarks Preservation Commission (LPC) shall consider Design Review applications for projects that involve landmarks, structures of merit, or buildings within a historic district. The LPC shall either approve, modify, or deny such applications in accordance with Section 23.406.070– Design Review.~~
- A. ~~Other~~ Responsibilities and Powers.
 - ~~1. As provided in Municipal Code Chapter 3.24 (Landmarks Preservation Commission), the LPC shall serve as the review authority for Structural Alteration Permits for designated landmarks, structures of merit, and buildings within a historic district.~~
 - 1. Municipal Code Chapter 3.24 identifies ~~additional LPC~~ the responsibilities and powers of the Landmarks Preservation Commission ~~which may affect land use and development in the city.~~
 - 2. **Design Review.** The Landmarks Preservation Commission (LPC) shall consider Design Review applications for projects that involve landmarks, structures of merit, or buildings within a historic district. The LPC shall either approve, modify, or deny such applications in accordance with Section 23.406.070– Design Review.

23.402.060 – Design Review Committee

- A. **Established.** The City shall establish and maintain a Design Review Committee (DRC) to review and approve the design of development projects in accordance with Section 23.406.070– Design Review.

B. Composition.

1. The DRC shall consist of seven members, as follows:
 - a. Two members of the Zoning Adjustments Board (ZAB).
 - b. One member of the Landmarks Preservation Commission (LPC).
 - c. One member of the Civic Arts Commission (CAC).
 - d. Three members of the public who are Berkeley residents.
2. DRC members from boards and commissions shall be appointed by their respective bodies, and members of the public shall be appointed by the ZAB.
3. DRC membership shall include at least two-licensed architects, one licensed landscape architect, and two laypersons (persons who are neither a planning or design professional nor an expert in the fields of land use planning, architecture, or landscape architecture).
4. The DRC shall elect a chairperson and vice chairperson

C. Responsibilities and Powers.

1. The DRC shall consider applications for Design Review and either approve, modify, or deny such applications in accordance with Section 23.406.070 (Design Review).
2. The DRC may make a recommendation on other matters upon request by the ZAB, Planning Commission, City Council, or other City boards or commissions. ~~ZAB DRC~~ recommendations shall be limited to the subject areas of its expertise issues related to building and site design.

D. Procedures. The DRC shall adopt rules of procedure and shall keep a record of its proceedings. A majority of the appointed members shall constitute a quorum.

23.402.070 – Zoning Adjustments Board

A. Established. The City shall establish and maintain a Zoning Adjustments Board (ZAB) to administer the Zoning Ordinance as described in this section.

B. Composition.

1. The ZAB shall consist of nine members appointed by the City Council in accordance with Municipal Code Chapter 2.04 (City Council).
2. The ZAB shall elect a chairperson and vice chairperson.

C. Responsibilities and Powers.

1. The ZAB:

- a. Serves as the review authority on applications as shown in Table 23.402-1: Review and Decision-Making Authority;
 - b. Hears appeals on decisions in accordance with Chapter 23.410—Appeals and Certifications;
 - c. Modifies previously approved Use Permits and Variances in accordance with Section 23.404.070— Permit Modifications;
 - d. Revokes Use Permits and Variances in accordance with Section 23.404.080— Permit Revocation;
 - e. Recommends actions to enforce the zoning ordinance, including to abate a public nuisance in accordance with Chapter 23.414—Nuisance Abatement;
 - f. Refers persons to a conflict resolution or mediation service in accordance with Section 23.404.050.K (Use of Conflict Resolution and Mediation Service);
 - g. Makes recommendations on other matters as requested by the City Council, ~~and~~ Planning Commission, or any other City Board or Commission; and
 - h. Adopts administrative regulations and procedures for the administration of the Zoning Ordinance.
2. The City Council may assign additional responsibilities to the ZAB as needed in the administration of the Zoning Ordinance.

D. **Procedures.** The ZAB shall adopt rules of procedure and keep a record of its proceedings. A majority of the appointed members constitutes a quorum.

23.402.080 – Planning Commission

The Planning Commission:

- A. Recommends to the City Council amendments to the Zoning Ordinance in accordance with Chapter 23.412 (Zoning Ordinance Amendments);
- B. Approves revisions to Design Review guidelines and standards as provided in Section 23.406.070 (Design Review); and
- C. Performs other duties as provided in Municipal Code Chapter 3.28 (Planning Commission).

23.402.090 – City Council

The City Council:

- A. Takes action on proposed Zoning Ordinance amendments in accordance with Chapter 23.412 (Zoning Ordinance Amendments);

- B. Hears appeals on and certifies decisions in accordance with Chapter 23.410 (Appeals and Certification); and
- C. Assumes other responsibilities and take actions on other matters related to the Zoning Ordinance in accordance with the Municipal Code and state and federal laws.

23.404 COMMON PERMIT REQUIREMENTS

Sections:

- 23.404.010– Purpose and Applicability
- 23.404.020– Application Submittal
- 23.404.030– Application Review
- 23.404.040– Public Notice
- 23.404.050– Public Hearings and Decisions
- 23.404.060– Post-Decision Provisions
- 23.404.070– Permit Modifications
- 23.404.080– Permit Revocation

23.404.010 – Purpose and Applicability

This chapter establishes requirements that apply to all discretionary permits required by the Zoning Ordinance.

23.404.020 – Application Submittal

- A. **Application Submittal.** Applications for discretionary permits required by the Zoning Ordinance shall be submitted to the Planning and Development Department (“Department”).
- B. **Application Form and Contents.**
 - 1. Applications shall be made in writing on a form provided by the Department.
 - 2. Applications shall identify one person as the applicant.
 - 3. Applications shall be filed with all information and materials required by the Department. Depending on the type of project and required permit, required information and materials may include plans, renderings, models, photographs, material samples, reports, studies, and other items necessary to describe existing conditions and the proposed project.
 - 4. All submitted application materials become City property available to the public.
 - 5. The applicant is responsible for the accuracy and completeness of all information submitted to the City.
- C. **Eligibility for Filing.** An application may be filed by:
 - 1. The owner of the subject property;
 - 2. An agent with written authorization to represent the owner;
 - 3. A person under contract or with an exclusive option to purchase the property, with written consent of the current owner;
 - 4. A tenant with written consent of the owner or the owner’s authorized designee; or
 - 5. An agency lawfully instituting eminent domain proceedings.

D. Pre-Application Notice Posted by Applicant.

1. Before submitting an application for a discretionary permit, an applicant shall post a conspicuous notice of the proposed project readily visible from the street adjacent to the property's primary frontage.
2. The form and contents of the notice shall be as specified by the Department.

E. Application Fees.

1. When Required.

- a. An application shall be accompanied by all required fees listed in the current Fee Schedule approved by the City Council.
- b. The Department will process an application only if all required fees are paid, unless the City approves a fee waiver in accordance with Paragraph 2 (Fee Waivers) below. The Department will not deem an application complete if a required fee remains unpaid.
- c. Application fees are not required when the City is the applicant, or when a fee is waived under any other provision of the Municipal Code.

2. Fee Waivers. In addition to seeking a fee waiver or deferral under other provisions of the Municipal Code, an applicant may request a fee waiver or deferral as follows:

- a. An applicant shall submit to the Department a written request for a fee waiver or deferral before submitting the application. The request shall identify the amount of all Current Planning fees required for the project and describe the reasons why the fee waiver or deferral is necessary.
- b. The Director shall forward the request to the City Manager. The City Manager may approve the request upon finding that:
 - i.* The project will provide a significant public service or benefit, and
 - ii.* The waiver or deferral is necessary to make the project economically feasible to construct or establish.
- c. The City Manager shall notify the City Council of a decision to approve a requested fee waiver or deferral. At its discretion, the City Council may reverse the City Manager's decision and deny the request.
- d. If the request is approved, the applicant shall include with the application a letter from the City Manager authorizing the fee waiver or deferral. The Department will accept the application only if submitted with the City Manager's letter.

3. Refunds and Withdrawals.

- a. If an application is withdrawn before a decision, the applicant may be eligible for a refund of a portion of the fee.
- b. The amount of the refund shall be determined by the Zoning Officer based on the level of staff review conducted to date. Refunds of fees may not be made for denied applications.

F. Multiple Permit Applications.

1. **Zoning Ordinance Discretionary Permits.** The following procedures apply to proposed projects that require multiple discretionary permits under the Zoning Ordinance (e.g., Use Permit and Variance).
 - a. An applicant shall request City approval of all required permits as part of a single application unless the Zoning Officer waives this requirement.
 - b. The Department shall process multiple permit applications for the same project concurrently.
 - c. City action on projects requiring multiple permits shall occur as follows:
 - i.* Concurrently for permits reviewed by the same review authority (e.g., the Zoning Adjustments Board (ZAB) concurrently reviews and acts on a Variance and Use Permits required for a project); and
 - ii.* Sequentially for permits reviewed by different review authorities, as necessary (e.g., the City Council approves a Zoning Map amendment before ZAB action on a Use Permit).
2. **Design Review.** See Section 23.406.070 (Design Review) for the Design Review application process.
3. **Other Permits.**
 - a. Separate applications are required for permits required by portions of the Municipal Code outside of the Zoning Ordinance. The City will review and act on these applications in a separate but coordinated process from applications required under the Zoning Ordinance.
 - b. For example, if a project requires both a Use Permit approved by the ZAB and a Structural Alteration Permit (SAP) approved by the Landmarks Preservation Commission (LPC), then a separate SAP application is required. A SAP application is processed separately from the Use Permit applications and is scheduled for consideration at a hearing before the LPC.

23.404.030 – Application Review

A. Review for Completeness.

1. **Determination of Completeness.** Department staff shall determine whether an application is complete based on the Department application submittal checklist.
 2. **Request for Additional Information.** If it is not complete, the Department shall inform the applicant in writing as to the information and materials needed to complete the application.
 3. **Review Timeline.** The Department shall review and determine whether an application is complete within the timelines required by Government Code Section 65920 et seq. (Permit Streamlining Act).
- B. Record of Date of Complete Application.** The Department shall record the date the application is deemed complete.
- C. Referrals to Landmarks Preservation Commission.** At every regular Landmarks Preservation Commission (LPC) meeting, the Department shall provide the LPC a list of all pending permit applications.
- D. Project Evaluation and Staff Reports.**
1. **Staff Evaluation.** The Department shall review all applications to determine if they comply with the Zoning Ordinance, the General Plan, and other applicable City policies and regulations and state laws.
 2. **Staff Report.** For all applications requiring review by the ZAB and City Council, the Department shall prepare a staff report describing the proposed project and including, where appropriate, a recommendation to approve, approve with conditions, or deny the application.
 3. **Report Distribution.** The staff report shall be given to the applicant after it is provided to the review authority and before action on the application.
- E. Environmental Review.**
1. **CEQA Review.**
 - a. After acceptance of a complete application, the Department shall review the project in compliance with the California Environmental Quality Act (CEQA) and any adopted City CEQA guidelines.
 - b. The City shall determine the required level of environmental review (e.g., exemption, Negative Declaration) within the timeframe required by CEQA.
 2. **Special Studies Required.** Special studies, paid for in advance by the applicant, may be required to supplement the City's CEQA compliance review.
- F. Summary Denial of Applications.**
1. **Section Purpose.** This section describes the process by which the Zoning Officer may deny an application without notice or hearing ("summary denial") for

property subject to City action to abate a public nuisance or correct a Zoning Ordinance violation.

2. Applications Subject to Summary Denial.

- a. The Zoning Officer may summarily deny an application that would legalize a structure or use subject to a final City order under 23.414 (Nuisance Abatement).
- b. The Zoning Officer shall not summarily deny applications for permits that are necessary comply with any such order.

3. Factors to Consider. When deciding whether to deny such an application, the Zoning Officer shall consider:

- a. Whether the project will be detrimental to the health, safety, peace, morals, comfort or general welfare of persons residing or working in the area or neighborhood of the proposed use;
- b. Whether the project will be detrimental or injurious to property and improvements of the adjacent properties, the surrounding area or neighborhood or to the general welfare of the City;
- c. Whether the applicant had an adequate opportunity to submit the application before the adoption of a final order under Chapter 23.414 (Nuisance Abatement); and
- d. The level of permit applied for (i.e., AUP, Use Permit, or Variance). Applications for Variances as a means of legalizing a violation are particularly disfavored.

4. Hearing Not Required. A public hearing is not required for the Zoning Officer to summarily deny an application.

5. Decision is Final. A decision by the Zoning Officer to summarily deny an application is final and may not be appealed.

23.404.040 – Public Notice

A. Notice of Administrative Decisions.

- 1. **When Required.** A Notice of Administrative Decision shall be given after the Zoning Officer's decision on an Administrative Use Permit (AUP).
- 2. **Content of Notice.** A Notice of Administrative Decision shall contain the following information:
 - a. A description of the proposed project in the AUP application.
 - b. The Zoning Officer's decision on the AUP application.

- c. The location and times in which the application may be reviewed by the public.
 - d. The procedure and time period in which the decision may be appealed to the Zoning Adjustments Board (ZAB).
 - e. The address where appeals may be filed.
3. **Timing of Notice.** A Notice of Administrative Decision shall be posted and mailed after the Zoning Officer's decision on the AUP.
4. **Notice Posting.** A Notice of Administrative Decision shall be posted at:
- a. Three visible locations in the vicinity of the subject property; and
 - b. The lobby of the Permit Service Center.
5. **Notice Mailing.**
- a. **Minimum Requirement.** A Notice of Administrative Decision shall be mailed to the following:
 - i.* Neighborhood and community organizations with a registered interest in receiving notice of the proposed project. See Section 23.404.040.E (Public Notice).
 - ii.* For projects in or adjacent to a Residential District, the owners and residents of the abutting properties.
 - iii.* For major residential additions in the R-1 district within the Hillside overlay zone, the owners and residents of properties within a 300-foot radius of the subject property.
 - iv.* The City of Berkeley Central Library.
 - b. **Additional Notice.** The Zoning Officer may include a larger area to receive a mailed notice when the proposed project may impact a larger area.
6. **Temporary Uses and Structures.** An AUP for a temporary use or structure is subject to the same notice requirements as other AUPs, except that notice shall be provided at least 14 days before the establishment of the temporary use or structure.
7. **Failure to Receive Notice.** The validity of the decision shall not be affected by the failure of any property owner, resident, or neighborhood or community organization to receive a mailed notice.

B. Public Hearing Notice.

1. **When Required.** Public notice shall be given as required by this section for:

- a. Zoning Adjustment Board (ZAB) hearings on Use Permits, Variances, and other decisions requiring a public hearing as specified in the Zoning Ordinance; and
 - b. City Council hearings on appeals of ZAB decisions.
2. **Content of Notice.** Notice of a public hearing shall contain the following information:
- a. The date, location, and time of the hearing.
 - b. A written description of the proposed project, including the number of dwelling units and floor area if applicable.
 - c. Maps, plans, and other information needed to describe and illustrate the proposed project, as determined necessary by the Department.
 - d. The environmental review status under the California Environmental Quality Act (CEQA).
 - e. Directions on how to obtain further information about the proposed project or hearing.
 - f. The location and times the application may be reviewed by the public.
 - g. Instructions to submit written comments on the proposed project.
3. **Timing of Notice.** Notices shall be posted and mailed at least 14 days before the hearing unless a longer notice period is required by state law. The Zoning Officer or ZAB may extend the notice period to a maximum of 30 days for applications of major significance.
4. **Notice Posting.** A notice of public hearing shall be posted:
- a. At three visible locations in the vicinity of the subject property:
 - b. At the Civic Center (Old City Hall); and
 - c. In the lobby of the Permit Service Center.
5. **Notice Mailing.**
- a. **Minimum Requirement.** A notice of public hearing shall be mailed to the following:
 - i. The owners and residents of the abutting and confronting properties.
 - ii. For the construction or demolition of one or more dwelling units, all property owners and residents within 300 feet on the same street or streets as the proposed project, including the abutting properties to the rear and within a 300-foot radius of the subject property.

- iii. For a relocated building, all property owners and residents within a 300-foot radius of both the existing and proposed new location of the building.
 - iv. Neighborhood and community organizations with a registered interest in receiving notice of the proposed project. See Section 23.404.040.E (Public Notice).
 - v. The City of Berkeley Central Library.
 - vi. Any person who has filed a written request for notice.
- b. **Additional Notice.** The Zoning Officer, ZAB, or City Council may include a larger area to receive a mailed notice when deemed appropriate.
 - c. **Failure to Receive Notice.** The validity of the hearing shall not be affected by the failure of any property owner, resident, or neighborhood or community organization to receive a mailed notice.
6. **Master Use Permit.** For a Master Use Permit application, all businesses, residents, and property owners within 500 feet of the subject property shall receive a notice in addition to the notice recipients listed in Paragraph F.1 (Minimum Requirement) above.

C. Public Notice for Zoning Ordinance Amendments.

- 1. **When Required.** Public notice shall be given as required by this section for Planning Commission and City Council hearings on proposed Zoning Ordinance Amendments.
- 2. **Content of Notice.** Notice of a public hearing shall contain the following information:
 - a. The date, location, and time of the hearing.
 - b. A written description of the proposed amendment.
 - c. A map showing the location of a proposed Zoning Map amendment, if applicable.
 - d. The environmental review status under the California Environmental Quality Act (CEQA).
 - e. Directions on how to obtain further information about the proposed amendment or hearing.
 - f. Instructions to submit written comments on the proposed amendment.
- 3. **Timing of Notice.** Notice shall be provided at least 14 days before the hearing unless a longer notice period is required by state law. The Planning Commission or City Council may require an extended notice period for applications of major significance.

4. **All Zoning Ordinance Amendments.** The following notice requirements apply to all Zoning Ordinance Amendments.
 - a. Notice shall be posted at the Civic Center (Old City Hall) and in the lobby of the Permit Service Center.
 - b. Notice shall be mailed to:
 - i. Neighborhood and community organizations with a registered interest in receiving notice of the proposed amendment. See Section 23.404.040.E (Public Notice).
 - ii. The City of Berkeley Central Library; and
 - iii. Any person who has filed a written request for notice.
5. **Zoning Ordinance Text Amendments.** In addition to requirements in Paragraph 4 (All Zoning Ordinance Amendments) above, notice of a Zoning Ordinance Text Amendment shall be published in a newspaper of general circulation in the city:
 - a. At least 14 days before the hearing; and then again
 - b. At least 7 days before the hearing.
6. **Zoning Ordinance Map Amendments.** The following notice requirements apply to Zoning Ordinance Map Amendments in addition to requirements in Paragraph 4 (All Zoning Ordinance Amendments) above.
 - a. **Less than 5 Acres.** For Zoning Map Amendments affecting an area less than 5 acres, public notice shall be:
 - i. Posted at three visible locations in the vicinity of the subject property; and
 - ii. Mailed to subject property owners, residents and tenants of the subject property, and all property owners, residents, and tenants within 300 feet of any part of the subject property.
 - b. **5 Acres or More.** For Zoning Map Amendments affecting an area 5 acres or more, public notice shall be:
 - i. Posted on each street frontage adjacent to the subject property.
 - ii. Mailed to all property owners, residents, and tenants within the subject property.
 - iii. Published twice in a newspaper of general circulation in the city at least 14 days before the hearing, and then again at least 7 days before the hearing.
7. **Additional Notice.** The Zoning Officer, Planning Commission, and City Council may require additional public notice as determined necessary or desirable.

8. **Failure to Receive Notice.** The validity of the hearing shall not be affected by the failure of any property owner, resident, tenant, or neighborhood or community organization to receive a mailed notice.

D. **Public Notice for Design Review.**

1. **Staff-Level Design Review.**

- a. **When Required.** Notice of Design Review shall be posted on or adjacent to the subject property at least 14 days before staff decision on Design Review application.
- b. **Notice Contents.** A Notice of Design Review shall contain the following information:
 - i. A description of the proposed project.
 - ii. Staff's anticipated decision on the Design Review application.
 - iii. The location and times at which the application may be reviewed by the public.
 - iv. The procedure and time period in which appeals to the Design Review Committee may be made.
 - v. The address where such appeals may be filed.

2. **Design Review Committee Meetings.**

- a. **Meeting Agenda.** Agendas for Design Review Committee (DRC) meetings shall be posted at the Civic Center (Old City Hall) at least 72 hours before the meeting. The agenda must list all projects and discussion items to be considered at that DRC meeting.
- b. **Posting and Mailing Notice Not Required.** There is no requirement to mail notices or post a notice on a subject property in advance of the DRC meeting.

E. **Registry of Organizations to Receive Notice.**

1. The Department shall maintain a registry of neighborhood and community organizations to receive notices of public hearings and administrative decisions.
2. An organization shall be included in the registry shall submit a written request to the Department with the following information:
 - a. The name and address of the organization.
 - b. The names, addresses and phone numbers of the contact persons.
 - c. The geographic area of interest, shown on a map, for which notices will be sent to the organization.

3. It is the responsibility of the organization to inform the Department of any changes to the organization information identified in Paragraph (2) above.

23.404.050 – Public Hearings and Decisions

- A. **General.** Hearings shall be conducted in a manner consistent with the requirements of State and local law and the procedures approved by the review authority.
- B. **Time and Place of Hearing.** A hearing shall be held at the date, time and place for which notice was given, unless the required quorum of review authority members is not present.
- C. **Public Comment.** All hearings shall be open to the public, which have the opportunity to present their views and be heard in accordance with established procedures.
- D. **Quorum Required for Action.** A majority of the members of review authority must be present to take action on an application.
- E. **Continued Hearings.**
 1. Any public hearing may be continued from time to time without further notice, provided that the chair of the review authority announces the date, time, and place to which the hearing will be continued before the adjournment or recess of the hearing.
 2. Hearings may not be continued beyond the time limits for reviewing applications established by the Permit Streamlining Act, CEQA, and other state and federal laws unless the applicant expressly waives their rights relating to time limits for City action on a pending application.
- F. **Action.**
 1. After the close of public hearing, the review authority shall either approve, modify, or deny the application; continue the hearing to a future date; or refer the application to a mediation or conflict resolution service.
 2. If an application is referred to mediation, it must return to the review authority for action.
- G. **CEQA.** For projects not subject to a CEQA exemption, the review authority that approves the application takes final action on the project's CEQA determination. Final action on the CEQA determination, when required, shall occur before or concurrent with action on required permits. The City is not required to take final action on CEQA documents for denied applications.
- H. **Conditions of Approval.**

1. The review authority may attach conditions to any permit as it deems reasonable or necessary to achieve consistency with the General Plan and Zoning Ordinance, and to promote the public health, safety, and welfare.
2. As a condition of approval, the City may require an applicant to provide adequate financial security to guarantee the proper completion of an approved project.
3. Any approval may be subject to time limits.

I. Exceptions to Protect Constitutional Rights.

1. The ZAB or City Council may waive or limit the application of any Zoning Ordinance requirement to a development project if it finds that such requirement would result in a deprivation of the applicant's constitutional rights.
2. The burden of establishing that this exemption applies is on the applicant.

J. Use of Conflict Resolution or Mediation Service

1. **General.** The ZAB or Zoning Officer may refer an applicant and neighbors to a conflict resolution or mediation service to resolve conflicts over a proposed project.
2. **Eligible Services.** The ZAB or Zoning Officer may refer participating parties only to a conflict resolution or mediation service on a pre-approved list maintained by the City.
3. **Non-Binding Results.** The results of the conflict resolution or mediation service shall be non-binding on the final decision of the ZAB or Zoning Officer.
4. **Timing of Referral.** A referral may be made at any time after an application is deemed complete and before a final decision on the application.
5. **Additional Meetings Allowed.** Nothing in this section prevents the parties from meeting on their own at any time, with or without a mediator, in an attempt to resolve their differences.
6. **Early Discussions Encouraged.** The City encourages applicants and neighbors to discuss proposed projects early in the project-planning process so that differences may be resolved before the submission of an application.
7. **Payment for Service.** The applicant shall pay for the cost of conflict resolution or mediation service.
8. **Rules and Expectations.** Mediation and conflict resolution shall be conducted in accordance with the following provisions, a copy of which shall be made available to participating parties, before beginning the process.

- a. The goal of mediation is to seek a mutually agreeable result for the pending application.
- b. Participation for the applicant and others parties is strictly voluntary.
- c. All participants shall be made aware that there is no City requirement to come to an agreement.
- d. The ZAB or Zoning Officer shall direct the mediator as to what issues are to be addressed in the mediation process. The mediator may ask the ZAB or the Zoning Officer for a clarification of these issues from time to time.
- e. Department staff will be available to provide the mediating parties with information on rights and requirements prescribed by the Zoning Ordinance.
- f. The mediation service will provide the ZAB or the Zoning Officer with a report as to the result of the mediation within 45 days of the referral.
- g. If no agreement between the parties is reached within 45 days, or at any time that the mediator indicates that further meetings between parties is futile, the ZAB or Zoning Officer shall proceed with making a decision on the application. If the parties to the mediation/conflict resolution agree to continue the mediation process, the process may be extended for an additional time period not to exceed 45 days. Unless the applicant expressly waives their rights relating to time limits for City action on a pending application, in no case shall the time periods for mediation cause the application review period to exceed the time limits prescribed by state or federal law.
- h. Participants in mediation are advised that the ZAB or Zoning Officer cannot deny applicants the opportunity to develop their properties in a reasonable manner. The Zoning Ordinance requires that a project must meet all minimum requirements and any other applicable City ordinances and regulations.
- i. Results of the mediation will in no way be binding upon the City, and the ZAB or Zoning Officer may approve, deny, or modify any aspect of any mediated agreement.
- j. A participant who has indicated either agreement or disagreement with the results of a mediation is in no way bound by their decision, and may change their mind after the mediation.
- k. Participation in a mediated meeting, or agreement with the results of a mediation, affects in no way the statutory right of any party to appeal the ZAB or Zoning Officer decision.
- l. Only those aspects of a mediated agreement that are either incorporated into the approved plans of a project, or are made conditions of approval, shall be enforceable by the City.

K. Resubmittal of Same Application.

1. **Resubmittals Prohibited.** For twelve months following the denial of a discretionary permit application, the Department may not accept an application that is the same or substantially similar to the previously denied application, unless:
 - a. The application was denied without prejudice; and/or
 - b. Evidence or substantially changed conditions warrant resubmittal as determined by the Zoning Officer.
2. **Determination.** The Zoning Officer shall determine whether an application is the same or substantially similar to the previously denied application.
3. **Appeal.** The determination of the Zoning Office may be appealed to the ZAB, in compliance with Chapter 23.410 (Appeals and Certification).

L. Notice of ZAB Decisions.

1. A Notice of Decision shall be issued after the ZAB:
 - a. Approves, modifies, or denies a Use Permit or Variance application; or
 - b. Takes action on an appealed decision.
2. The Notice of Decision shall be issued before the ZAB's next regular meeting and shall describe the ZAB's action, findings, and applicable conditions.
3. The Notice of Decision shall be posted in the lobby of the Permit Service Center and shall be mailed to:
 - a. The applicant;
 - b. The appellant, if applicable;
 - c. Any person who has filed a written request for notice; and
 - d. The City of Berkeley Central Library.
4. The Notice of Decision shall be filed with the City Clerk and provided to the ZAB. The City Clerk shall make the notice available to interested members of the City Council and the public.

23.404.060 – Post-Decision Provisions

A. Effective Dates.

1. **Council Decisions.**
 - a. A City Council decision on a Zoning Ordinance Amendment and other legislative matters is final and becomes effective 30 days after the decision is made.

- b. A City Council decision on permits, appeals, and other non-legislative matters is final and effective on the date the decision is made.
- 2. **Other Decisions.** The following applies to decisions of the Zoning Officer, Design Review Committee, and ZAB.
 - a. A non-appealable decision is final and effective on the date the decision is made.
 - b. An appealable decision is final and effective upon the completion of the appeal period for the decision if the decision is not appealed or certified by the City Council as provided in Chapter 23.410 (Appeals and Certifications).

B. Effect of Approval.

- 1. **Approval Limited to Proposed Project.** An approval authorizes only the proposed project described in the application. In no way does an approval authorize other uses, structures or activities not included in the project description.
 - 2. **Replacement of Existing Uses.** When the City approves a new use that replaces an existing use, any prior approval of the existing use becomes null and void when permits for the new use are exercised (e.g., building permit or business license issued). To reestablish the previously existing use, an applicant must obtain all permits required by the Zoning Ordinance for the use.
 - 3. **Periodic Review and Reporting.**
 - a. The City may require periodic review of an approved project to verify compliance with permit requirements and conditions of approval.
 - b. The permit holder or property owner is responsible for complying with any periodic reporting, monitoring, or assessments requirement.
 - 4. **Conformance to Approved Plans.**
 - a. **Compliance.** All work performed under an approved permit shall be in compliance with the approved plans and any conditions of approval.
 - b. **Changes.** Changes to an approved project shall be submitted and processed in compliance with Section 23.404.070 (Permit Modifications).
- C. Time Limits.** This subsection applies to approved permits that have not been exercised.
- 1. **Exercised Defined.**
 - a. A permit authorizing a land use is exercised when both a valid City business license is issued (if required) and the land use is established on the property.

- b. A permit authorizing construction is exercised when both a valid City building permit (if required) is issued and construction has lawfully begun.

2. Expiration of Permit.

- a. The Zoning Officer may declare a permit lapsed if it is not exercised within one year of its issuance, except as provided in Paragraph (b) below.
- b. A permit authorizing construction may not be declared lapsed if the applicant has applied for a building permit or has made a substantial good faith effort to obtain a building permit and begin construction.
- c. The Zoning Officer may declare a permit lapsed only after 14 days written notice to the applicant.
- d. A determination that a permit has lapsed may be appealed to the ZAB in accordance with Chapter 23.410 (Appeals and Certification).

- 3. Effect of Lapsed Permit.** A permit declared lapsed shall be void and of no further force and effect. To establish the use or structure authorized by the lapsed permit, an applicant must apply for and receive City approval of a new permit.

- D. Permits Remain Effective for Vacant Property.** Once a permit for a use is exercised and the use is established, the permit authorizing the use remains effective even if the property becomes vacant. The same use as allowed by the original permit may be re-established without obtaining a new permit.

23.404.070 – Permit Modifications

- A. Purpose and Applicability.** This section establishes requirements and procedures for an applicant to request modification to an approved discretionary permit.
- B. Permit Modification Required.** City approval of a permit modification is required to:
- 1. Expand the floor or land area devoted to an approved use;
 - 2. Expand a customer service area and/or increase the number of customer seats;
 - 3. Change a building's occupant load rating under the City's Building Code so that it is classified in a different category with a higher occupancy rating;
 - 4. Increase the number of employees, beds, rooms or entrances;
 - 5. Establish a new product line, service, function or activity so as to substantially change the character of the use;
 - 6. Increase the volume of production, storage or capacity of any business manufacturing process or activity;

7. Change the type of alcohol sales and/or service; and
8. Change, expand, or intensify a use or structure in any other manner or substantially alters the use or structure.

C. **Review Authority.** A permit shall be modified by the review authority which originally approved the permit.

D. **Public Notice and Hearing.**

1. **Exercised Permits.** Public notice and hearing in compliance with this chapter is required to modify a permit that has been exercised. See Section 23.404.060.C.1 (Exercised Defined).
2. **Permits Not Yet Exercised.** For modifications to permits not yet exercised, the Zoning Officer or ZAB may act on the permit modification without a public hearing, or may set the matter for public hearing at its discretion. A noticed public hearing for a permit modification shall occur in compliance with this chapter.

E. **New Building Permits Required.** A building permit may not be modified after construction is complete. New construction in accordance with a modified permit requires issuance of a new building permit.

23.404.080 – Permit Revocation

A. **Purpose and Applicability.**

1. This section establishes procedures for the City to revoke or modify a discretionary permit for completed projects due to:
 - a. Violations of permit requirements;
 - b. Changes to the approved project; and/or
 - c. Vacancy for one year or more.
2. Notwithstanding anything to the contrary, no lawful residential use can lapse, regardless of the length of time of the vacancy.
3. Expiration of permits not yet exercised are addressed in Section 23.404.060.C (Time Limits).

B. **Initiation.**

1. Proceedings to revoke or modify a permit may be initiated by Zoning Officer, Zoning Adjustments Board (ZAB), or City Council referral.
2. Such referral shall identify the permit being considered, the property to which the permit applies, and the reason for the potential revocation or modification.
3. The Zoning Officer shall determine the public hearing date for all referrals.

C. ZAB Recommendation.

1. Public Hearing.

- a. The ZAB shall hold a public hearing on a permit revocation or modification in compliance with Section 23.404.050 (Public Hearings and Decisions). Notice shall be given in conformance with Section 23.404.040.B (Public Hearing Notice).
- b. The Department shall notify the current permit holder of the date, time, and location of the hearing.

2. ZAB Recommendation.

- a. The ZAB may recommend that the City Council revoke or modify the permit based upon the findings shown in Subsection E (Findings) below.
- b. The ZAB recommendation shall be:
 - i. Based on the evidence, testimony, and facts presented to the ZAB at the hearing;
 - ii. Supported by written findings; and
 - iii. Issued within 35 days after the conclusion of the hearing.

3. **Final Decision.** A ZAB recommendation to deny or modify a permit shall be deemed a final decision if the permit holder consents to the recommendation within 10 days after the recommendation is made. In such a case, there shall be no City Council review and action on the matter.

4. **Report to City Clerk.** The Department shall file the ZAB's recommendation with the City Clerk within 14 days following the recommendation.

D. City Council Action.

1. **Report to Council.** The City Clerk shall present a ZAB recommendation to the City Council at soonest possible regular City Council meeting.

2. Public Hearing.

- a. If the ZAB recommends that the City Council revoke or modify the permit, the City Council shall hold a public hearing on the matter within 60 days after the ZAB issued its recommendation.
- b. If the ZAB does not recommend that the City Council revoke or modify the permit, the City Council may hold a public hearing on the matter at its discretion.

3. **Council Decision.** The City Council may modify or revoke the permit based upon the findings shown in Subsection E (Findings) below.

E. **Findings.** The City Council may revoke or modify a permit if any of the following findings can be made:

1. The permit holder has failed to comply with one or more of the conditions of approval.
2. The use or structure has been substantially expanded or changed in character beyond the approved project.
3. The property has been vacant for one year and the permit holder has not made a good faith effort to re-occupy the property with the use allowed by the approved permit.

G. **Notice of Decision.**

1. If the City Council revokes or modifies a permit, the City Clerk shall issue a Notice of Decision describing the City Council' s action, with its findings.
2. The City Clerk shall mail the notice to the permit holder, the property owner, the person who requested proceedings under this chapter (if any), and any person who requests such a notification.
3. The City Clerk shall file a copy of the Notice of Decision with the Department.

H. **Remedies.**

1. If the City revokes or modifies a permit, the City may impose any of the following remedies:
 - a. Enjoin the use in whole or in part.
 - b. Impose reasonable conditions upon any continued operation of the use, including existing non-conforming uses.
 - c. Require continued compliance with newly imposed any conditions.
 - d. Require the permit holder to guarantee compliance with newly imposed conditions.
2. If the permit holder fails to comply with newly imposed conditions, the City may impose additional conditions or enjoin the use in whole or in part.

I. **Recovery of Costs.**

1. **Permit Revocation and Modification.**

- a. The City may recover the costs to administer permit revocation and modification proceedings in accordance with Sections 1.24.140 through 1.24.210 of Municipal Code Chapter 1.24 (Abatement of Nuisances), except as provided in Paragraph (b) below.

- b. The hearing provided by Section 1.24.180 (Service of Notice of Hearing) shall be held by the City Manager or his/her designee and may be appealed to the City Council within ten days after a decision is mailed. The Council shall hold a hearing on appeals as shown in Section 1.24.180.

2. Remedies.

- a. The City Council may, by resolution, establish reasonable hourly rates which may be charged for the time spent by City employees in the performance of their employment under this section. These hourly rates may be charged on an on-going basis for time spent with respect to any building, structure or use if the City Council takes any action authorized by Subsection G (Remedies) above. In this case, payment of costs charged under this paragraph shall be made a condition of continued operation of the building, structure, or use.
- b. Payments submitted under this Paragraph 2 (Remedies) shall be deducted from any payments submitted under previous Paragraph 1 (Permit Revocation and Modification).

23.406 SPECIFIC PERMIT REQUIREMENTS

Sections:

- 23.406.010– Purpose
- 23.406.020– Zoning Certificates
- 23.406.030– Administrative Use Permits
- 23.406.040– Use Permits
- 23.406.050– Variances
- 23.406.060– Master Use Permits
- 23.406.070– Design Review
- 23.406.080– Modification of Development Standards in West Berkeley Plan Area
- 23.406.090– Reasonable Accommodations

23.406.010 – Purpose

This chapter identifies procedures for specific types of permits required by the Zoning Ordinance. See Chapter 23.404 (Common Permit Requirements) for procedures that apply generally to all types of permits.

23.406.020 – Zoning Certificates

A. Purpose. A Zoning Certificate is a ministerial approval to:

1. Confirm that a structure or land use complies with the Zoning Ordinance; and
2. Establish a record of the initial establishment of a structure or land use.

B. When Required.

1. Unless specifically stated otherwise in the Zoning Ordinance, a Zoning Certificate is required to:
 - a. Construct, modify, repair, or move a structure; and/or
 - b. Establish, change, or expand a land use.
2. A Zoning Certificate is not required to:
 - a. Continue a previously-approved use or structure; or
 - b. Establish a temporary use or structure allowed by right as shown in 23.302.030.A (Permitted By Right).

C. Applications.

1. Zoning Certificate applications shall be made in writing on a form provided by the Department accompanied by all fees, information, and materials as required by the Department.
2. An application fee is not required where the legal use of property or building is unchanged and no building alterations occur.

D. **Referrals.** The Zoning Officer may review applications referred from other City departments, including building permits and business licenses applications, and require that applicants submit Zoning Certificate applications and additional information as needed.

E. **Review and Action.**

1. The Zoning Officer shall review a Zoning Certificate application to verify compliance with the Zoning Ordinance. If the project complies with all applicable requirements, the Zoning Officer shall approve the application.
2. The Zoning Officer may attach to the Zoning Certificate project plans and other information as needed to document project compliance with the Zoning Ordinance.

F. **When Exercised.** A Zoning Certificate is considered exercised when either:

1. The approved use is established at the subject premises; or
2. In the case of construction, when a valid building permit, if required, is issued for the approved structure and construction has begun.

G. **Scope of Approval.** A Zoning Certificate applies only to the structures and uses shown in the application specifically approved through the application. A Zoning Certificate does not in any way validate or constitute approval of any building, structure, use, subdivision, or lot line adjustment not shown in the application.

H. **Appeals.** A decision on a Zoning Certificate may not be appealed.

I. **Non-Compliance.** A Zoning Certificate is considered null and void if a structure or land use is established:

1. Contrary to the project description attached to a Zoning Certificate approval; and
2. In a manner that violates the Zoning Ordinance or requires additional City approvals.

23.406.030 – Administrative Use Permits

A. **Purpose.** An Administrative Use Permit (AUP) is a discretionary permit approved by the Zoning Officer to ensure that a proposed project will not adversely impact neighboring properties or the general public.

B. **Review Authority.**

1. The Zoning Officer takes action on AUP applications.
2. For a project with special neighborhood or community significance, the Zoning Officer may refer an AUP application to the Zoning Adjustments Board (ZAB) for

review and final decision. In such an instance, the ZAB shall review and act on the application following the requirements that apply to Use Permit applications.

C. When Required. An AUP is required for:

1. Land uses and development projects in each district as identified in Chapters 23.202 – 23.210 (Zoning Districts);
2. Temporary land uses and structures in accordance with Section 23.302.030.B (AUP Required); and
3. Other types of development projects when specifically required by the Zoning Ordinance.

E. Public and City Franchise Uses. The Zoning Officer may issue an AUP for any accessory building for public use or any use on City-owned property that is subject to franchise by the City. Such an AUP is subject to the same appeal and certification procedures as all other AUPs.

F. Public Notice and Hearing. See Section 23.404.040.A (Notice of Administrative Decisions).

H. Findings for Approval.

1. To approve an AUP, the Zoning Officer shall find that the proposed project or use:
 - a. Will not be detrimental to the health, safety, peace, morals, comfort, or general welfare of persons residing or working in the area or neighborhood, of the proposed use; and
 - b. Will not be detrimental or injurious to property and improvements of the adjacent properties, the surrounding area or neighborhood or to the general welfare of the City.
2. To approve the AUP, the Zoning Officer must also make any other AUP findings specifically required by the Zoning Ordinance for the proposed project.
3. When taking action on an AUP, the Zoning Officer shall consider the following when making findings:
 - a. The proposed land use; and
 - b. The structure or addition that accommodates the use.
4. Required findings shall be made based on the circumstances existing at the time a decision is made on the application.
5. The Zoning Officer shall deny an AUP application if unable to make any of the required findings.

I. ZAB Notification. The Zoning Officer shall inform the ZAB of all AUP decisions.

23.406.040 – Use Permits

- A. **Purpose.** A Use Permit is a discretionary permit approved by the Zoning Adjustments Board (ZAB) to ensure that a proposed project will be designed, located, and operated to be compatible with neighboring properties and minimize impacts to the general public.
- B. **Review Authority.** The ZAB takes action on all Use Permit applications.
- C. **When Required.** A Use Permit is required for:
 - 1. Land uses and development projects in each district as identified in Chapters 23.202 – 23.210 (Zoning Districts).
 - 2. Other types of development projects when specifically required by the Zoning Ordinance.
- D. **Public Notice and Hearing.** The ZAB shall review and take action on a Use Permit application at a noticed public hearing in compliance with Chapter 23.404 (Common Permit Requirements).
- E. **Findings for Approval.**
 - 1. To approve a Use Permit, the ZAB shall find that the proposed project or use:
 - a. Will not be detrimental to the health, safety, peace, morals, comfort, or general welfare of persons residing or visiting in the area or neighborhood of the proposed use; and
 - b. Will not be detrimental or injurious to property and improvements of the adjacent properties, the surrounding area or neighborhood, or to the general welfare of the City.
 - 2. To approve the Use Permit, the ZAB must also make any other Use Permit findings specifically required by the Zoning Ordinance for the proposed project.
 - 3. When taking action on a Use Permit, the ZAB shall consider in its findings:
 - a. The proposed land use; and
 - b. The structure or addition that accommodates the use.
 - 4. Required findings shall be made based on the circumstances existing at the time a decision is made on the application.
 - 5. The ZAB shall deny a Use Permit application if it determines that it is unable to make any of the required findings.

23.406.050 – Variances

- A. **Purpose.** A Variance is a discretionary approval that allows for deviations from development standards and land use regulations in the Zoning Ordinance. The City

may grant a Variance only when the strict application of development standards creates a unique hardship due to unusual circumstances associated with the property.

B. When Allowed.

1. **Deviations Allowed with a Variance.** The ZAB may grant a Variance to allow for deviation from any provision in the Zoning Ordinance related allowed land uses, use-related standards, and development standards.
2. **Deviations Allowed with a Use Permit.** The ZAB may allow deviations from building setback, lot coverage, and on-site parking standards with a Use Permit instead of a Variance if:
 - a. The property is 30 feet or less from an open creek; and
 - b. Deviation from the standard is necessary to comply with Chapter 17.08 (Preservation and Restoration of Natural Watercourses).

C. Variances Not Allowed. A Variance may not be granted to allow deviation from a requirement of the General Plan.

D. Review Authority. The ZAB takes action on all Variance applications.

E. Public Notice and Hearing. The ZAB shall review and act on a Variance application at a noticed public hearing in compliance with Chapter 23.404(Common Permit Requirements).

F. Findings for Approval.

1. To approve a Variance, the ZAB shall make all of the following findings:
 - a. There are exceptional circumstances applying to the property which do not apply generally in the same district.
 - b. The Variance is necessary to preserve a substantial property right.
 - c. The Variance will not adversely affect the health or safety of persons residing or working near the property.
 - d. The Variance will not be materially detrimental to the public welfare or injurious to nearby property or improvements.
 - e. The Variance will promote the municipal health, welfare, and safety and benefit the city as a whole.
 - f. Any other Variance findings required by Zoning Ordinance can be made.
2. The ZAB shall deny a Use Permit application if it determines that it is unable to make any of the required findings.

23.406.060 – Master Use Permits

- A. **Purpose.** A Master Use Permit is a discretionary approval that allows flexibility in the amount of space occupied by individual tenants in a multi-user site. The purpose of a Master Use Permit is to:
1. Facilitate the implementation of the General Plan and area plans, including the West Berkeley Plan;
 2. Expedite the reuse of large and multi-user sites that might otherwise prove difficult to reuse;
 3. Facilitate the development and reuse of large, multi-user sites as integrated units in a stable and desirable environment to benefit occupants, the neighborhood, and the city as a whole.;
 4. Allow the review and analysis of impacts of multi-tenant projects in a coordinated, consolidated manner; and
 5. Improve Berkeley's competitiveness in attracting and retaining businesses by allowing businesses to quickly move into a site once overall development requirements have been established.
- B. **Review Authority.** The ZAB takes action on all Master Use Permit applications.
- C. **Voluntary Option.** A Master Use Permit is a voluntary option for property owners. If a property owner does not request and receive a Master Use Permit, individual tenants are subject to the Use Permit requirements that ordinarily apply as required by the Zoning Ordinance.
- D. **Where Allowed.** A property that meets the following criteria may apply for a Master Use Permit:
1. The property is located entirely or partially in one of the following districts:
 - a. Any Commercial District.
 - b. Mixed Use-Light Industrial (MU-LI).
 - c. Mixed Manufacturing (MM).
 - d. Manufacturing (M).
 2. The property will be occupied by three or more independently operating businesses.
- E. **Use Allocation.**
1. A Master Use Permit may allow by right more than one individual business and/or use on a site, provided that all other applicable requirements of the Zoning Ordinance are met.

2. A Master Use Permit shall state the square feet of buildings and land allocated for the following uses:
 - a. Industrial (manufacturing, wholesaling, and warehousing).
 - b. Office (excludes offices ancillary to other uses).
 - c. Commercial (retail, personal service, restaurants).
 - d. Live/work units.
 - e. Residential.

F. Allowed Variations.

1. The area of a building or site occupied by a use may exceed the Master Use Permit allocation with the permits shown in Table 23.406-1.

TABLE 23.406-1: ALLOWED VARIATION IN USE ALLOCATIONS

| Variation in Use Allocation from Master Use Permit | Permit Required |
|--|--------------------|
| 10% or less | No Permit Required |
| More than 10% to 25% | AUP |
| More than 25% | UP(PH) |

2. If the allocation of floor area for various uses as shown in Paragraph D (Where Allowed) above remains within the limits set forth in Table 23.406-1, lease spaces may be divided or aggregated in any manner as-of-right.

G. Public Notice and Hearing. The ZAB shall review and take action on a Master Use Permit application at a noticed public hearing in compliance with Chapter 23.404 (Common Permit Requirements).

H. Findings for Approval. To approve a Master Use Permit, the ZAB must find that approval will expedite occupancy and use of the site consistent with the purpose of the district, the General Plan, and any applicable area plan.

23.406.070 – Design Review

A. Purpose. Design Review is a discretionary process to ensure that exterior changes to non-residential buildings comply with the City of Berkeley Design Guidelines and other applicable City design standards and guidelines. The purpose of Design Review is to:

1. Encourage excellence in building and site design;
2. Ensure that development is compatible with its urban context; and

3. Provide a pleasing urban environment for persons living, working, or visiting the city.

B. When Required.

1. Design Review is required for:
 - a. Projects in all Non-Residential Districts.
 - b. Mixed use and community and institutional projects in the R-3 district within the Southside Plan area. See Figure 23.202-1: R-3 Areas Subject to Design Review; and
 - c. Commercial, mixed-use, and community and institutional projects in the R-4, R-SMU, and R-S districts.
2. As used in Paragraph (1) above, “project” means an activity requiring a building or sign permit that involves any of the following:
 - a. Modifying the exterior of an existing structure.
 - b. Additions to an existing structure.
 - c. Demolishing all or a portion of an existing structure.
 - d. Removing all or part of a building facade fronting the public right-of-way.
 - e. Constructing a new structure.
 - f. Installing or replacing a sign.

C. Design Review Process.

1. **Use Permit Projects.**
 - a. If a project requires a Use Permit, Preliminary Design Review is required before ZAB action on the Use Permit.
 - b. Review authority for Preliminary Design Review is described in Section 23.406.070.D (Review Authority).
 - c. The ZAB shall consider Preliminary Design Review recommendations when acting on the Use Permit. Before acting on the Use Permit, the ZAB may require further review by the Design Review Committee or Department staff as part of the Preliminary Design Review process.
 - d. As a condition of Use Permit approval, the ZAB may require Final Design Review to verify that the project conforms to design-related Use Permit conditions of approval or to review finalized project design details. The Design Review Committee conducts Final Design Review unless the ZAB directs staff to conduct Final Design Review as a condition of approval.

- e. If the ZAB requires Final Design Review, the City may issue a building permit only after Final Design Review is complete.

2. Projects Not Requiring a Use Permit.

- a. For a project that does not require a Use Permit, Department staff conducts Design Review before the Zoning Officer takes action on the required permit or approval.
- b. The Zoning Officer will consider the Design Review recommendations when acting on the required permit or approval. The Zoning Officer may require modifications to the project design as a condition of approval.
- c. The Department will verify conformance with Design Review recommendations and design-related conditions of approval when issuing a building permit, sign permit, or Zoning Certificate for the project. Final Design Review is not required.

D. Review Authority.

- 1. **Department Staff.** Department staff, under the supervision and authority of the Zoning Officer, conducts Design Review for projects that do not require a Use Permit, except when the Landmarks Preservation Commission (LPC) conducts Design Review as provided in Paragraph (3) below. Design review conducted by Department staff is referred to as “Staff-Level Design Review.”
- 2. **Design Review Committee.**
 - a. For projects requiring a Use Permit, Design Review is conducted by the Design Review Committee except as provided by Paragraph (b) below or when the Landmarks Preservation Commission (LPC) conducts Design Review as provided in Paragraph (3) below.
 - b. The Zoning Officer may determine that, due to unique circumstances, Department staff will conduct Design Review for a project requiring a Use Permit. The Zoning Officer, or Department staff on their behalf, shall confer with the Design Review Committee Chair before making such a determination and shall consider project size, visibility, and degree of sensitivity to the neighboring properties or the general public.
- 3. **Landmarks Preservation Commission.** The Landmarks Preservation Commission (LPC) conducts Design Review of projects which involve landmarks, structures of merit, or buildings within a historic district in accordance with Chapter 3.24 (Landmarks Preservation Commission). The LPC conducts Design Review for landmarked properties through the Structural Alteration Permit process.

E. Zoning Officer and LPC Referrals.

1. The Zoning Officer may refer any project subject to ZAB review to the Design Review Committee, staff, or the LPC for non-binding input on design-related issues. However, Design Review approval is required only for projects in Subsection B (When Required) above.
2. The LPC may refer any project subject to LPC review to the Design Review Committee for non-binding input on design-related issues.

F. Referrals to Landmarks Preservation Commission.

1. **Mandatory Referrals.** The following Design Review applications shall be referred to the LPC for review and comment before action on the application:
 - a. Projects that involve a building or structure listed on the State Historic Resources Inventory, or on the List of Structures and Sites adopted by the LPC under Chapter 3.24.
 - b. Projects that involve a building or a structure over 40 years old which may have special architectural or historical significance, as determined by the secretary to the LPC.
2. **Optional Referrals.** Department staff or the Design Review Committee may choose to refer the following projects to the LPC for review and comment before action of the application:
 - a. Projects that involve a building that is 40 years old or less that may have special architectural and/or historical significance, as determined by the secretary to the LPC.
 - b. Signs and awnings which involve a building or structure listed on the State Historic Resources Inventory, or on the LPC's current List of Structures and Sites.

G. Design Guidelines.

1. The City of Berkeley Design Guidelines provide direction to the City when reviewing proposed projects and assists applicants in planning and design of their projects. The Design Guidelines are intentionally generalized to encourage individual creativity. It is not expected that every project will respond to every guideline.
2. When conducting design review the Design Review Committee, the LPC, and staff shall use the Design Guidelines adopted by the Planning Commission as its official policy.
3. The Design Review Guidelines may be amended by the Planning Commission. The ZAB may comment to the Planning Commission on such amendments.

H. Scope of Design Review. Design Review considers only issues of building and site design and does not address land use issues. Site design included the

placement of buildings on a lot, vehicle access and circulation, pedestrian circulation, parking placement and design, landscaping, and other similar issues.

I. Design Review Timeline.

1. Design Review projects requiring an AUP or a Zoning Certificate shall be completed within 60 days of the date the application is deemed complete. If an applicant modifies the application, or if the applicant submits a written time extension, Department staff may extend the review period beyond 60 days.
2. Design Review for projects that require ZAB approval shall be completed within 60 days of submittal of complete final Design Review plans or within the time limit required by the Permit Streamlining Act, whichever is less.

J. Public Notice. Public notice of pending Design Review decisions shall be given in accordance with Section 23.404.040.D (Public Notice for Design Review).

K. Public Hearing. None required.

L. Design Review Committee Proceedings.

1. The Design Review Committee shall meet with the applicant and shall operate as a working group. Its meetings shall be open to the public.
2. Review of a project by the Design Review Committee may be continued as necessary subject to the timeline set forth in this chapter.
3. The Design Review Committee shall adopt its own rules and procedures.

M. Basis for Approval. The review authority shall consider a proposed project in relation to its surrounding context when acting on a Design Review application.

1. The review authority may approve a Design Review application only upon finding that the proposed project conforms with the City of Berkeley Design Guidelines and any City-adopted design standards and guidelines applicable to the project.
2. The review authority may consider public input during the Design Review process and may require modifications to the proposed project as a condition of Design Review approval.

N. Changes to Approved Projects.

1. **Design Review Modification (Minor Changes).** Before issuance of a building permit, Department staff may approve minor changes to a project with final Design Review approval if the change complies with all of the following criteria:
 - a. The change does not involve a feature of the project that was:
 - i.* A specific consideration by the review authority in granting the approval;
 - ii.* A condition of approval; or

- b. Less than five acres and forms a full city block bounded on all sides by public streets (exclusive of alleys), mainline railroad tracks, and/or the borders of the City.

C. **Allowed Modifications.** The ZAB may allow modifications to the following land use and development standards:

- 1. Permitted location of land uses within a building, site, or district.
- 2. Development standards including but not limited to, height, yards, open space, and parking.

D. **Project Phases.** The ZAB may approve a Modification of Development Standards application to allow a project to be built in phases.

E. **Limitation.** A Modification of Development Standards may not allow any modification that would violate Section 23.206.050 (Protected Uses).

F. **Review Authority.** The ZAB takes action on all Modification of Development Standards applications.

G. **Public Notice and Hearing.** The ZAB shall review and act on a Modification of Development Standards application at a noticed public hearing in compliance with Chapter 23.404 (Common Permit Requirements).

H. **Findings for Approval.**

- 1. To approve a Modification of Development Standards, the ZAB shall make all of the following findings:
 - a. The site is eligible for a Modification of Development Standards under Subsections B (Eligibility) and E (Limitation);
 - b. The project is likely to advance the purposes of the West Berkeley Plan and this section;
 - c. The project supports the attraction and/or retention of the types of businesses reflected in the purpose statement of the applicable district.
 - d. The modification is necessary and appropriate for the development of the proposed project.
- 2. To approve a Modification of Development Standards, the ZAB shall also make all required Use Permit findings in Section 23.406.040 (Use Permits) and any additional Use Permit findings required by the Zoning Ordinance for the use or development in the applicable district.

23.406.090 – Reasonable Accommodations

A. **Purpose.** This section establishes a process for the City to approve modifications to development regulations to support equal access to housing for persons with

disabilities. This process is established in accordance with the Federal Fair Housing Act, the Americans with Disabilities Act, and the California Fair Employment and Housing Act.

B. When Allowed.

1. Eligible Applicants.

- a. Any person with a disability, or their representative, may request reasonable accommodation as allowed by this section.
- b. A person with a disability is a person who has a physical or mental impairment that limits or substantially limits one or more major life activities, anyone who is regarded as having this type of impairment, or anyone who has a record of this type of impairment.

2. **Eligible Request.** An eligible applicant may request a modification or exception to any provision in the Zoning Ordinance or Subdivision Ordinance (Title 21) that acts as a barrier to fair housing opportunities for persons with disabilities.

C. Review Authority.

1. **Zoning Officer.** The Zoning Officer takes action on reasonable accommodation applications unless the application is filed for concurrent review with a requested permit reviewed by the Zoning Adjustments Board (ZAB).
2. **Zoning Adjustments Board.** If a reasonable accommodation application is submitted concurrently with a permit application reviewed by the ZAB, the reasonable accommodation application shall be acted on by the ZAB.
3. **Referral to Zoning Adjustments Board.** The Zoning Officer may refer any reasonable accommodation application to the ZAB for review and final decision.

D. Application Requirements.

1. **Application.** A request for reasonable accommodation shall be submitted on an official City application form. No application fee is required. The application shall include:
 - a. The name, address, and telephone number of the applicant;
 - b. The address of the property for which the accommodation is requested;
 - c. The current use of the property.
 - d. The ordinance provision for which modification is requested;
 - e. Reason that the requested accommodation may be necessary to enable the person with the disability to use the dwelling; and
 - f. Other information requested by the Zoning Officer.

2. **Concurrent Applications.** If the project for which the reasonable accommodation is requested requires another planning permit (e.g., Use Permit), the reasonable accommodation application shall be filed concurrently with the related permit application.

E. Review Procedure.

1. Independent Application.

- a. For a Reasonable Accommodation application submitted independently from any other planning permit application, the Zoning Officer shall take action within 45 days of receiving the application.
- b. If necessary to reach a determination on the request for reasonable accommodation, the Zoning Officer may request further information from the applicant consistent with fair housing laws. If a request for additional information is made, the 45-day period to issue a decision is stayed until the applicant submits the requested information.

2. **Concurrent Application.** For a reasonable accommodation request submitted concurrently with another planning permit application, the reasonable accommodation request shall be reviewed and acted upon concurrently with the other application.

F. Action on Application.

1. **Decision.** The review authority shall make a written decision supported by findings and conclusions to approve, approve with conditions, or deny the application.
2. **Criteria.** The review authority shall consider the following factors when acting on the application:
 - a. Need for the requested modification.
 - b. Alternatives that may provide an equivalent level of benefit.
 - c. Physical attributes of and proposed changes to the property.
 - d. Whether the requested modification would impose an undue financial or administrative burden on the City.
 - e. Whether the requested modification would constitute a fundamental alteration of the City's zoning or subdivision regulations.
 - f. Whether the requested accommodation would result in a concentration of uses otherwise not allowed in a residential neighborhood to the substantial detriment of the residential character of that neighborhood.
 - g. Any other factor that may have a bearing on the request.

3. **Conditions of Approval.** The review authority may impose conditions of approval, including a condition to provide for the automatic expiration of the approval under appropriate circumstances (e.g., person with disability vacates home).

G. **Appeals.** Reasonable accommodation decisions may be appealed in accordance with Chapter 23.410 (Appeals and Certification).

23.408 GREEN PATHWAY

Sections:

- 23.408.010– Purpose
- 23.408.020– Applicability
- 23.408.030– Eligibility Determination
- 23.408.040– Green Pathway Application
- 23.408.050– General Requirements
- 23.408.060– Requirements for Large Buildings and Hotels
- 23.408.070– Development Standards
- 23.408.080– Streamlined Permitting Process
- 23.408.090– Tolling
- 23.408.100– Compliance
- 23.408.110– City Manager Authority to Issue Regulations

23.408.010 – Purpose

- A. The purpose of this chapter is to implement the “Green Pathway” provisions of Measure R (2010) by providing a voluntary streamlined permit process for buildings that:
 - 1. Exceed the Green Building requirements applicable in the C-DMU district; and
 - 2. Provide extraordinary public benefits that could not otherwise be obtained, as specified in this chapter.
- B. This chapter establishes standards and requirements to clarify the City’s expectations for projects eligible for approval under this chapter and to ensure they will be designed and developed consistent with the Downtown Area Plan.

23.408.020 – Applicability

This chapter applies only to development projects in the Downtown Mixed Use (C-DMU) district that:

- A. Do not propose alteration or demolition of a historical resource as defined by the California Code of Regulations Title 14, Section 15064.5; and
- B. Will not have a significant adverse impact on any adjacent historical resource as defined by the California Code of Regulations Title 14, Section 15064.5.

23.408.030 – Eligibility Determination

- A. **RFD Purpose.** To determine if a project is eligible for processing under this chapter, an applicant shall submit to the City a Request for Determination (RFD). The RFD process applies to development projects that may be eligible for Green

Pathway processing notwithstanding anything to the contrary in Chapter 3.24 (Landmarks Preservation Commission).

B. RFD Submittal. A property owner or the owner's authorized agent shall request the Landmarks Preservation Commission (LPC) to determine whether the subject property, as well as each adjacent property, is an historical resource under the California Code of Regulations Title 14, Section 15064.5, by submitting a RFD. Potential historical resources include, but are not limited to, properties identified in any of the following sources:

1. Downtown Plan and EIR (Adopted 1990).
2. State Historic Preservation Office California Historical Resources Information System Historical Resources Inventory for Alameda County, City of Berkeley (Most Recent).
3. Any site identified as a potential resource needing further evaluation in the Downtown Area Plan Historic Resource Evaluation (Architectural Resource Group, 5 November 2008).

C. Processing an RFD.

1. The City shall not accept an RFD unless it is accompanied by proof that the applicant has posted a conspicuous notice on the subject property in a location that is readily visible from the street on which the structure or site has its major frontage. Such notice shall be in a form specified by the Zoning Officer.
2. Upon receiving a RFD, the City shall contract with an independent consultant from a list of qualified consultants approved by the LPC to prepare an historic resource assessment. The costs of the assessment shall be borne by the applicant. Alternatively, the applicant for a RFD may submit its own historic resource assessment, which shall then be subject to peer review by the City's consultant at the applicant's expense. If a property that is the subject of the RFD is not identified on any of the lists in Subsection B (RFD Submittal) above, the applicant's assessment may consist of a statement of why the applicant believes the property does not include an historical resource.
3. A RFD shall be deemed complete upon completion of the City consultants' historic resource assessment or peer review that determines that the applicant's submitted historic resource assessment is complete and accurate.
4. The LPC shall begin its consideration of whether to designate a property that is the subject of a RFD at a public hearing at the first regular meeting that occurs no less than 21 days after the RFD is complete, and shall take final action no later than 90 days after it is complete. Notice of the public hearing shall be provided as set forth in Municipal Code Section 3.24.140 (Designation proposal-- Public hearing notice requirements).

- D. **Timeline Extensions; Failure to Act.** Any of the timelines specified in this section may be extended at the written request of the applicant. Failure to act within any of the timelines set forth in this section, as they may be extended, shall constitute a decision to take no action to designate.
- E. **When Chapter 3.24 Applies.** If a property that is the subject of a RFD is not designated within the time limitations set forth in this section, Municipal Code Chapter 3.24 (Landmarks Preservation Commission) shall not apply to that property unless and until the earliest of the following occurs:
 - 1. The expiration of two years from the date of any final action not to designate the property; or
 - 2. If an application under this chapter is submitted within that period, then either:
 - a. The application is withdrawn or denied; or
 - b. Any entitlement approved for the property expires, is cancelled or revoked, or for any other reason ceases to have effect.
- F. **Appeal and Certification.** Decisions by the LPC under this section shall be subject to appeal as set forth in Section 3.24.300 (Appeals--Procedures required--City Council authority), and certification as set forth in Section 3.24.190 (Council certification authorized when—Effect).
- G. **Effect of Determination** If a subject property is determined to be an historical resource as defined by California Code of Regulations, Title 14, Section 15064.5, it shall not be processed as a Green Pathway Project under this chapter.

23.408.040 – Green Pathway Application

- A. **Voluntary Option.** The Green Pathway authorized by this chapter is a voluntary development option under which applicants for development projects in the C-DMU district may waive certain rights and agree to certain obligations the City could not otherwise impose in return for certain processing benefits.
- B. **Application Contents.** An application for processing using the Green Pathway shall include the information otherwise required by the Zoning Ordinance for the entitlement sought, as well as:
 - 1. The applicant's commitment to enter into binding agreements to satisfy all applicable Green Pathway requirements if the application is approved; and
 - 2. Proof that the LPC has not taken any action under Section 23.408.030 (Eligibility Determination) to designate the subject property as a structure of merit or landmark under Chapter 3.24 (Landmarks Preservation Commission).
- C. **Additive Requirements.** Except as expressly specified in this chapter, the requirements of this chapter are in addition to, and do not change or replace any

other requirements or standards of the Zoning Ordinance and Chapter 3.24 (Landmarks Preservation Commission).

23.408.050 – General Requirements

All Green Pathway projects are subject to the following requirements.

A. Affordable Units.

1. In addition to any other applicable affordable housing mitigation fee or requirement, at least 20 percent of the total units in a proposed multi-unit rental development shall be rented to very low income households whose annual income does not exceed 50 percent of the annual median income for Alameda County adjusted for household size based upon income levels published by the U.S. Department of Housing and Urban Development.
2. Rents for these units shall be set at prices affordable to very low income households, as defined by Section 50053 of the California Health and Safety Code for the life of the project.
3. As an alternative, an applicant may pay an in-lieu fee to the Housing Trust Fund as established by the City Council.

B. Density Bonus. The applicant shall waive, in writing, any rights under State Density Bonus Law, Section 65915 of California Government Code.

C. Local Hire Requirement.

1. The applicant shall sign an agreement that no less than 30 percent of a project's construction workers will be Berkeley residents.
2. If insufficient Berkeley residents are available to fulfill the 30 percent local hire requirement, then the next tier of residents shall come from the East Bay Green Corridor (which includes the cities of Albany, Alameda, Berkeley, El Cerrito, Emeryville, Hayward, Richmond, Oakland, and San Leandro).
3. If insufficient residents are available from the Green Corridor to fulfill the 30 percent local hire requirement, then residents of Alameda County will be used to fulfill the local hire requirements.
4. An applicant who agrees to require employment of Berkeley residents on another project the applicant is building or has approval to construct in Berkeley may count such employment toward the 30 percent local hire requirement by providing the same documentation the City requires to show compliance with paragraphs 1 and 2 of this subsection.

D. Use Regulations. Uses shall comply with the requirements and limitations of Section 23.204.130 (C-DMU Downtown Mixed-Use District).

23.408.060 – Requirements for Large Buildings and Hotels

In addition to the requirements of Section 23.408.050 (General Requirements), a Green Pathway project that includes either a hotel, a building over 75 feet in height, or a building with more than 100 units of housing, are subject to the following requirements.

A. Prevailing Wage.

1. All construction workers shall be paid state prevailing wage as established by the California Department of Industrial Relations.
2. Employees in hotels with a height over 75 feet shall be paid prevailing wages as established by the Department of Industrial Relations for hotel employees. If the Department of Industrial Relations does not establish prevailing wages for hotel employees, such employees shall be paid wages consistent with area mean wages per occupational category.

B. State Certified Apprenticeship Program. To the extent that enough qualified apprentices are reasonably available, no less than 16 percent of the construction workers shall be apprentices from a State Certified Apprenticeship program with a record of graduating apprentices.

C. Requirements Binding to Future Owners. As a condition of approval for any Green Pathway project subject to the requirements of this section, the owner shall enter into a written agreement that shall be binding on all successors in interest.

23.408.070 – Development Standards

Green Pathway projects shall comply with the applicable development standards in Section 23.204.130 (C-DMU Downtown Mixed-Use District) and the following additional requirements.

A. Building Setbacks Within View Corridors. To minimize interference with significant views, buildings that are 75 feet in height or less that are located on a corner lot at any intersection with University Avenue, Center Street, or Shattuck Avenue must include upper story setbacks as follows: any portion of a building between 45 feet and 75 feet must be set back from property lines abutting the street by at least one foot for every one foot by which the height exceeds 45 feet.

B. Street Wall Facade. Notwithstanding the Downtown Design Guidelines, the street wall facade shall be architecturally modulated by volumes that are 50 feet in width or less.

1. Smaller modulations may be incorporated within larger volumes.
2. Volumes along the street wall must be defined by structural bays and/or substantial reveals or offsets in the wall plane, and by changes in the rhythmic pattern of one or more of the following features:

- a. Window openings, oriel windows, or balconies.
- b. Awnings, canopies, or entrances.
- c. Arcades, columns, or pilasters.
- d. Materials and color.
- e. Other architectural features.

C. **Shadow Analysis.** A shadow analysis is required for buildings with heights between 60 and 75 feet. Applications shall include diagrams showing:

1. The extent of shading on public sidewalks and open spaces by a building 60 feet in height that complies with all applicable setback requirements on an area within a radius of 75 feet of the closest building wall that would be cast on March 21, June 21, December 21, and September 21 at the following times of day:
 - a. Two hours after sunrise;
 - b. 12 p.m. noon; and
 - c. Two hours before sunset.
2. Features incorporated into the building design, including, but not limited to, additional upper floor setbacks that will reduce the extent of shadowing of the proposed building to no more than 75 percent of the shadowing projected in previous Paragraph (1).

D. **Height Restrictions.** Consistent with the height standards of Measure R (adopted November 2, 2010), Section 4.B., as required by Section 3, Paragraph 12, Green Pathway Buildings of exceptional height are restricted as follows:

1. Two mixed-use buildings and one hotel/conference center in the Core, no more than 180 feet in height.
2. Two buildings, up to 120 feet in height in the Core or Outer Core.

E. **Mitigation Measures.** To ensure that potential environmental impacts are mitigated to less than significant levels, projects under this chapter are subject to applicable measures identified in the adopted Mitigation Monitoring Program of the Downtown Area Plan Final EIR.

23.408.080 – Streamlined Permitting Process

A. **Projects Involving Only Buildings at or Below 75 Feet in Height.**

1. **Projects Allowed By Right.** Notwithstanding anything to the contrary in the Zoning Ordinance, Green Pathway projects that do not involve either hotels, buildings over 75 feet, or buildings with more than 100 units of housing, shall be approved as a matter of right with a Zoning Certificate if they comply with the

applicable zoning requirements, standards, and requirements in this chapter and the Downtown Design Guidelines. Such projects are subject to Design Review under Section 23.406.070 (Design Review).

2. **Historic Resource.** If a proposed Green Pathway project is adjacent to a property that has been determined to be an historic resource under Section 23.408.030 (Eligibility Determination), the application for a Green Pathway project shall include an analysis demonstrating how the project meets the Secretary of the Interior's Standards for the Treatment of Historic Properties, including guidelines for the treatment of cultural landscapes with respect to such adjacent property.
 - a. After determining that the application is complete, the Zoning Officer shall forward the analyses described in Subsections A and B of Section 23.408.030 (Eligibility Determination) to the Secretary of the LPC to place on the agenda for the next regular meeting of the LPC that occurs no less than 21 days thereafter. The LPC shall then have 90 days in which to evaluate the submission and provide any comments to the Design Review Committee (DRC).
 - b. The DRC shall determine whether a project conforms to the Secretary of the Interior's Standards for the Treatment of Historic Properties and the associated guidelines, including the standards and guidelines for the treatment of cultural landscapes, with respect to adjacent historical resources. A project that clearly conforms to those standards and guidelines shall be considered to not have a significant impact on the historical resource. If the DRC determines that the proposed project would have a significant adverse impact on any adjacent historical resource and the project is not modified to avoid that impact, it shall not be processed as a Green Pathway project.
3. **Downtown Design Guidelines.**
 - a. Notwithstanding Section 23.406.070 (Design Review), the DRC shall determine whether the project conforms to the Downtown Design Guidelines and shall take final action on the project no later than 90 days from the date the application for a Green Pathway project, including for Design Review, is complete.
 - b. When determining whether a project subject to review under this section conforms to the Downtown Design Guidelines, the DRC shall treat applicable guidelines as standards.
 - c. The decision of the DRC regarding whether the project conforms to the Guidelines may be appealed directly to the City Council by filing an appeal stating the reasons for the appeal, along with the required fee, with the City Clerk within 14 days of the date of the DRC action. Design Review appeals shall be limited to design issues.

B. Projects Involving Buildings Over 75 Feet in Height.

1. Notwithstanding anything to the contrary in the Zoning Ordinance, the Zoning Adjustments Board (ZAB) shall take final action on a Green Pathway project over 75 feet in height or any other project not processed under previous Subsection (A) no later than 210 days after the application is complete, provided that this time limit shall be extended as necessary to comply with the California Environmental Quality Act (CEQA).
2. Such projects shall receive priority status to meet the review timeframes set forth in this section.

23.408.090 – Tolling

Timelines under this chapter shall be extended by the time taken for any proceedings pursuant to Chapter 3.24 (Landmarks Preservation Commission) relating to a Green Pathway project.

23.408.100 – Compliance

The applicable public benefit requirements of this chapter shall be included as conditions of approval and in a binding agreement for all Green Pathway projects.

23.408.110 – City Manager Authority to Issue Regulations

The City Manager or his/her designee may promulgate rules and regulations pertaining to this chapter, including, but not limited to

- A. Setting and administering gross rents and sale prices for below-market-rate units; and
- B. Specifying and requiring guarantees, including recorded agreements and other appropriate measures necessary or convenient to assure that required below-market-rate units are provided to and occupied by very low income households, and that other public benefits set forth in this chapter are secured.

23.410 APPEALS AND CERTIFICATIONS

Sections:

- 23.410.010– Chapter Purpose
- 23.410.020– Appeal Subjects and Jurisdiction
- 23.410.030– Filing and Processing of Appeals
- 23.410.040– Hearing and Decision
- 23.410.050– City Council Certifications

23.410.010 – Chapter Purpose

This chapter establishes procedures for the appeal and certification of City actions made when administering the Zoning Ordinance.

23.410.020 – Appeal Subjects and Jurisdiction

- A. **General.** City actions made when administering the Zoning Ordinance may be appealed as shown in Table 23.410-1: Appeal Subjects and Review Authority.
- B. **Code Enforcement Appeals.** See Municipal Code Chapter 1.24 (Abatement of Nuisances).
- C. **Landmarks Preservation Commission Appeals.** Decisions by the Landmarks Preservation Commission (LPC) when administering the Zoning Ordinance shall be appealed in accordance with Municipal Code Chapter 3.24 (Landmarks Preservation Commission).

TABLE 23.410-1: APPEAL SUBJECTS AND REVIEW AUTHORITY

| ACTION | ORDINANCE SECTION | MAY BE APPEALED BY | IS APPEALED TO | MUST BE FILED WITHIN |
|---|-------------------|--------------------|------------------|--|
| Zoning Officer Actions | | | | |
| AUP decisions | 23.406.030 | Any person | ZAB | 20 days of posting Notice of Administrative Decision [1] |
| Staff-level Design Review | 23.406.070 | Any person | ZAB | 14 days of posting the Notice of Design Review |
| Zoning Officer Reasonable Accommodation decisions [2] | 23.406.090 | Applicant | ZAB | 14 days of mailing notice of decision |
| Termination of an AUP for sidewalk cafe seating | 23.302.060 | Permit holder | City Manager [3] | 14 days of mailing of termination notice |
| Determination of lapsed permit | 23.404.080 | Permit holder | ZAB | 20 days of mailing determination notice |
| Design Review Committee Actions | | | | |
| Any Design Review action | 23.406.070 | Any person | ZAB [4] | 14 days of Committee action |
| Zoning Adjustments Board Actions | | | | |
| Use Permit decisions | 23.406.040 | Any person | City Council | 14 days of mailing Notice of Decision |
| Variance decisions | 23.406.050 | Any person | City Council | 14 days of mailing Notice of Decision |
| Decisions on an appeal | 23.410 | Any person | City Council | 14 days of mailing Notice of Decision |
| <u>Notes:</u> | | | | |

| ACTION | ORDINANCE SECTION | MAY BE APPEALED BY | IS APPEALED TO | MUST BE FILED WITHIN |
|---|-------------------|--------------------|----------------|----------------------|
| <p>[1] The Zoning Officer may extend the appeal period for a longer time.</p> <p>[2] For reasonable accommodation requests associated with a project requiring a discretionary permit (e.g., Use Permit), the appeal procedures are the same as for the discretionary permit.</p> <p>[3] The City Manager's decision is final. No further appeal is allowed.</p> <p>[4] Determinations of conformity with Downtown Design Guidelines for Streamlined Entitlement Process (Section 23.408.090.C) is appealed directly to the City Council.</p> | | | | |

23.410.030 – Filing and Processing of Appeals

- A. **General.** Appeals shall be filed and processed consistent with Chapter 23.404 (Common Permit Requirements) except as otherwise specified in this chapter.
- B. **Eligibility and Timing of Appeal.** Table 23.410-1 shows who is eligible to file an appeal and the date by which an appeal must be filed.
- C. **Appeal Fees.**
 - 1. Appeal fees shall be paid by the person filing the appeal (the appellant) except as provided in Paragraph (2) below.
 - 2. The City shall not charge a fee for appeals of projects denied due to conflicting decisions of the Zoning Adjustments Board (ZAB) and Landmarks Preservation Commission as described in Sections 3.24.200 through 3.24.240 of Chapter 3.24 (Landmarks Preservation Commission).
- D. **Form of Appeal.**
 - 1. An appeal shall be submitted to the Department or City Clerk in writing together with all required application fees and shall include the name and contact information of the appellant.
 - 2. The appeal application shall state the pertinent facts and the basis for the appeal.
 - 3. The whole decision or part of the decision may be appealed. If an appellant chooses, an individual finding, action, or condition may be appealed.
- E. **Appeal Subject – Design Review.** Appeals of the Design Review Committee and staff-level Design Review decisions are limited to design-related issues.
- F. **Takings Claims.**
 - 1. If a basis of an appeal is that the review authority's action constituted a taking of property under the California or United States Constitutions, that basis and all supporting evidence and argument shall be clearly stated as a basis of the appeal, or it shall be waived.
 - 2. If specific evidence is not presented as part of the appeal, the takings claim shall be waived, and appellant shall be deemed to have waived any claim to sworn testimony and cross-examination.
 - 3. This requirement shall apply to appeals on the basis that the review authority's decision or any condition of approval:
 - a. Denied the applicant any reasonable economic use of the subject property;
 - b. Was not sufficiently related to a legitimate public purpose;
 - c. Was not sufficiently proportional to any impact of the project; or

d. For any other reason constituted a taking of property for public use without just compensation.

G. **Copy to Zoning Officer.** If the appeal is submitted to the City Clerk, the City Clerk shall forward a copy to the Zoning Officer.

H. **Notice to Applicant.** If the appeal is made by someone other than the applicant, the Department shall forward a copy of the written appeal to the applicant.

I. **Effect of Appeal.** Once an appeal is filed, any action on the associated project is suspended until the appeal is processed and a final decision is made by the review authority.

23.410.040 – Hearing and Decision

A. Scheduling of Hearing.

1. Upon receiving an appeal, the Department shall schedule a hearing with the appropriate review authority.
2. For appeals of projects denied due to conflicting decisions of the ZAB and Landmarks Preservation Commission, the City Council shall schedule a hearing at the earliest feasible date after the final ZAB or Landmarks Preservation Commission action.
3. Any appeal of a Design Review decision shall be heard by the review body within 45 days of the appeal filing.
4. All appeals on a single project shall be considered together at the same hearing.

B. **Public Notice.** Notice of appeal hearings shall be given in accordance with Section 23.404.040 (Public Notice).

C. **Staff Report and Materials.** Before the hearing, Department staff shall prepare a staff report describing the appeal with relevant supporting materials.

D. **Hearing Procedures.** Public hearings on an appeal shall be conducted in accordance with applicable procedures in Section 23.404.040 (Public Notice).

E. De Novo Review.

1. The review authority may take action on the subject of the appeal or any aspect of the appealed project (de novo review), except as provided in Paragraph (2) below.
2. For appeals of Design Review decisions, the review authority may take action only on design-related issues.

F. **Public Comment.** The review authority may consider written correspondence concerning the appeal that is submitted after the appeal is filed, as well as any other information or evidence permitted under the Council Rules of Procedure.

G. **Action.** At the appeal hearing, the review authority may:

1. Continue the public hearing;
2. Modify, reverse, or affirm, wholly or partly, any decision, determination, condition or requirement of the prior review authority; or
3. For appeals to the City Council, remand the matter to the prior review authority to reconsider the application, and/or any revisions to the application submitted after the review authority's action.

H. **Criteria for Decision.**

1. When acting on an appeal, the appeal review authority shall use the same decision-making criteria and shall make the same findings as the prior review authority.
2. The review authority's action shall be based upon findings of fact about the appeal and shall identify the reasons for action on the appeal. In doing so, the appeal review authority may adopt the prior review authority's decision and findings as its own.

I. **Timeframe for Action – Use Permit and Variance Appeals.** If the City Council does not act on a Use Permit or Variance appeal within 30 days from the date the public hearing was closed by the City Council, then the decision of the ZAB shall be deemed affirmed and the appeal denied.

J. **Board Action on Remand.**

1. A ZAB decision on an appeal remanded by the City Council may be appealed in the normal manner unless otherwise directed by the City Council.
2. If the ZAB does not act within 90 days after an appeal is remanded by the City Council, the original appeal of the ZAB's decision shall be placed back on the City Council agenda in the same manner as a new appeal.

K. **Effective Date of Appeal Decisions.**

1. **City Council Decision.** The City Council's decision on an appeal is final and becomes effective on the date the decision is made.
2. **ZAB Decisions.** Decisions on appeals made by the ZAB becomes effective 14 days after the mailing of the Notice of Decision.

23.410.050 – City Council Certifications

- A. **Purpose.** Certification is an action by the City Council to review a decision by the ZAB or LPC.
- B. **Eligible Actions.** The City Council may certify the following actions for review:
 - 1. Decisions of the ZAB on Use Permit and Variance applications.
 - 2. Decisions of the LPC on historic resource designations as provided in Section 3.24.190 (Council certification authorized when—effect).
- C. **Initiation.**
 - 1. Any Council member may initiate the certification process by submitting a written request to the City Clerk within:
 - a. 14 days from the mailing of the Notice of Decision for ZAB decisions; and
 - b. 15 days from the mailing of the Notice of Decision for LPC decisions.
 - 2. Certification shall not require any statement of reasons or justification and shall not represent opposition to or support of an application.
- D. **Effect of Certification.** After initiating certification, any action on the associated project is suspended until City Council review is completed.
- E. **Hearing and Decision.** Certified actions shall be reviewed by the City Council at a noticed public hearing in the same manner as for appeals as described in Section 23.410.040 (Hearing and Decision).

23.412 ZONING ORDINANCE AMENDMENTS

Sections:

- 23.412.010– Purpose
- 23.412.020– Initiation
- 23.412.030– Application
- 23.412.040– Planning Commission Hearing and Action
- 23.412.050– City Council Hearing and Action
- 23.412.060– Findings for Approval
- 23.412.070– Limitations on Resubmittals after Denial
- 23.412.080– Zoning Map Amendment Notations

23.412.010 – Purpose

This chapter establishes procedures for amending the Zoning Ordinance, including the Zoning Map and Zoning Ordinance text. All amendments to the Zoning Ordinance shall be processed as set forth in Government Code Section 65853 et seq. and as specified in this chapter.

23.412.020 – Initiation

- A. **Zoning Map Amendment.** A Zoning Map amendment may be initiated by:
 - 1. Resolution of the City Council or Planning Commission; or
 - 2. Application of one or more owners of the property for which the amendment is sought.
- B. **Zoning Ordinance Text Amendment.** A Zoning Ordinance text amendment may be initiated by resolution of the City Council or Planning Commission.

23.412.030 – Application

An application for a Zoning Map amendment submitted by a property owner shall be filed and reviewed in compliance with Section 23.404.020 (Application Submittal). The application shall include the information and materials required by the Planning and Development Department, together with all required application fees.

23.412.040 – Planning Commission Hearing and Action

- A. **Public Hearing.** The Planning Commission shall hold a public hearing on a proposed Zoning Ordinance Amendment in compliance with Section 23.404.040 (Public Notice).
- B. **Planning Commission Recommendation.**
 - 1. The Planning Commission may recommend that the City Council approve, conditionally approve, or deny the proposed Zoning Ordinance Amendment based upon the findings specified in Section 23.412.060 (Findings for Approval).

2. A recommendation for approval shall be made by a majority vote of the total membership of the Planning Commission.
3. If the Planning Commission recommends denial of a Zoning Map amendment, the City Council is not required to take further action on the proposed amendment unless the City receives a written request from an interested party for a City Council hearing within ten days after the Planning Commission action.

C. Recommendation Expiration.

1. A Planning Commission recommendation shall expire and have no further effect if the City Council takes no action on a proposed Zoning Ordinance Amendment within six months after the date the Planning Commission approved the recommendation.
2. The City Council may extend the effective period of a Planning Commission recommendation for up to an additional 18 months.

23.412.050 – City Council Hearing and Action

A. Public Hearing. After receiving the Planning Commission's recommendation, the City Council shall hold a public hearing on the proposed Zoning Ordinance Amendment in compliance with Section 23.404.050 (Public Hearings and Decisions).

B. Council Action.

1. General.

- a. The City Council may approve, conditionally approve, or deny the proposed Zoning Ordinance Amendment based upon the findings specified in Section 23.412.060 (Findings for Approval).
- b. The action by the City Council shall be made by a majority vote of the total membership of the City Council.

2. Referral to Planning Commission.

- a. If the City Council proposes to adopt a substantial modification to the Zoning Ordinance Amendment not previously considered by the Planning Commission, the proposed modification shall be first referred to the Planning Commission for its recommendation.
- b. The failure of the Planning Commission to report back to the City Council within 40 days after the reference, or within the time set by the City Council, shall be deemed a recommendation of approval.

C. Effective Date. Zoning Ordinance Amendments become effective 30 days after the adoption of the ordinance by the City Council, or at a later date as determined by the City Council.

23.412.060 – Findings for Approval

The City Council may approve a Zoning Ordinance Amendment only if all of the following findings are made:

A. Findings for all Zoning Ordinance Amendments.

1. The proposed amendment is consistent with the General Plan and any applicable specific plan or area plan.
2. The proposed amendment is consistent with state law.
3. The proposed amendment will not be detrimental to the public interest, health, safety, convenience, or welfare.

B. Additional Finding for Zoning Ordinance Text Amendments. The proposed amendment is internally consistent with other applicable provisions of the Zoning Ordinance.

C. Additional Finding for Zoning Map Amendments. The affected site is physically suitable in terms of design, location, shape, size, and other characteristics to ensure that the permitted land uses and development will comply with the Zoning Ordinance and General Plan and contribute to the health, safety, and welfare of the property, surrounding properties, and the community at large.

23.412.070 – Limitations on Resubmittals after Denial

A. One-Year Prohibition. If the City denies a Zoning Map Amendment, the City may not accept a resubmitted application for the same or substantially similar Zoning Map Amendment within one year from the date of denial, unless:

1. The original application is denied without prejudice; or
2. The City Council allows resubmittal within six-months of denial as allowed by Subsection B (Six-Month Exception) below.

B. Six-Month Exception.

1. The City Council may allow a resubmitted application within six months from the date of denial if the Council finds that:
 - a. Changed circumstances in relation to the property warrant early resubmittal, and
 - b. Any property owner objections to the original application have been withdrawn.
2. The burden rests with the applicant to submit evidence and show that the findings in Paragraph B.1 above can be made.

23.412.080 – Zoning Map Amendment Notations

All adopted amendments to the Zoning Map shall be noted on the map with the date and number of the amending ordinance.

23.414 NUISANCE ABATEMENT

Sections:

- 23.414.010– Purpose
- 23.414.020– Enforcement Responsibility
- 23.414.030– Violations a Misdemeanor
- 23.414.040– Nuisances Prohibited
- 23.414.050– City Attorney Action
- 23.414.060– Abatement Procedures
- 23.414.070– Statements of Violations
- 23.414.080– Remedies
- 23.414.090– Recovery of Costs
- 23.414.100– Private Right of Action

23.414.010 – Purpose

This chapter establish procedures to abate public nuisances associated with land uses, structures, and events as regulated by the Zoning Ordinance. These procedures supplement generally applicable code enforcement provisions in Municipal Code Title 1 (General Provisions).

23.414.020 – Enforcement Responsibility

The City Manager, or their designee, shall enforce the requirements of this chapter.

23.414.030 – Violations a Misdemeanor

Any violation of the Zoning Ordinance is a misdemeanor but may be cited or charged, at the City’s discretion, as an infraction. In all other respects, the provisions of Municipal Code Chapter 1.20 (General Penalty) apply.

23.414.040 – Nuisances Prohibited

- A. **Public Nuisance Prohibited.** A land use, structure, or event shall not cause a public nuisance as defined in Subsection (B) below.
- B. **Public Nuisance Defined.** A use, structure, or event that meets any of the following criteria is a public nuisance.
 - 1. Any of the following activities: disturbances of the peace, illegal drug activity including sales or possession thereof, public drunkenness, drinking in public, harassment of passers-by, gambling, prostitution, public vandalism, excessive littering, excessive noise (particularly between the hours of 11:00 p.m. and 7:00 a.m.), noxious smells or fumes, curfew violations, lewd conduct or police detention, citations or arrests, or any other activity declared by the City to be a public nuisance.
 - 2. A violation of any City, state, or federal ordinance, law, or regulation.

3. A use or activity, other than one that takes place at a dwelling and is sponsored by a resident of that dwelling, that is conducted in a manner that results in a disturbance of any kind that requires six Berkeley Police Department patrol officers after 11:00 p.m. and before 2:00 a.m., or three Berkeley Police Department patrol officers at any other time, to quell such disturbance.

23.414.050 – City Attorney Action

- A. **Immediate Action.** The City Attorney may take immediate action to abate, remove, and enjoin a public nuisance in the manner provided by law.
- B. **Judicial Relief.** To abate a public nuisance, the City Attorney may apply for relief from the courts to:
 1. Remove a use or structure;
 2. Prevent the establishment of a use or structure;
 3. Prevent the continued operation of a use or structure; or
 4. Prevent the removal or demolition of a structure.

23.414.060 – Abatement Procedures

- A. **Initiation.**
 1. Proceedings to abate a nuisance may be initiated by Zoning Officer, Zoning Adjustments Board (ZAB), or City Council referral.
 2. A nuisance abatement referral shall identify the subject property, the nature of the violation, and the reason for the proposed abatement.
 3. After receiving a nuisance abatement referral, the Zoning Officer shall schedule the matter for a public hearing.
- B. **ZAB Recommendation.**
 1. **Public Hearing.**
 - a. The ZAB shall hold a public hearing on the proposed abatement in compliance with Section 23.404.050 (Public Hearing and Decision).
 - b. The Department shall provide notice of the hearing to the property owner, property occupants, the person who requested proceedings under this chapter (if any), and any person who has filed written request of notice.
 2. **Recommendation.**
 - a. The ZAB shall recommend that the City Council determine whether a nuisance exists and, if so, the appropriate remedy.
 - b. The ZAB recommendation shall be:

- i.* Based on the evidence, testimony, and facts presented to the ZAB at the hearing;
 - ii.* Supported by written findings; and
 - iii.* Issued within 35 days after the conclusion of the hearing.
3. **Final Decision.** A ZAB recommendation to abate a nuisance shall be deemed a final decision if the property owner consents to the recommendation within 10 days after the recommendation is made. In such a case, there shall be no City Council review and action on the matter.
4. **Report to City Clerk.** The Department shall file the ZAB's recommendation with the City Clerk within 14 days following the recommendation. The City Clerk shall present a ZAB recommendation to the City Council at soonest possible regular City Council meeting.

C. **City Council Action.**

1. **Public Hearing.** The City Council shall hold a public hearing on the proposed abatement in compliance with Section 23.404.050 (Public Hearing and Decision). The hearing shall occur within:
 - a. 60 days of the ZAB recommendation if the ZAB recommends abatement; and
 - b. 30 days of the City Clerk report to the City Council of the ZAB decision.
2. **Decision.** After hearing, the City Council may find that the use, structure, or event constitutes a public nuisance and may impose any remedy provided for in this chapter, or take no action.

D. **Notice of Decision.**

1. If the City Council makes a nuisance determination, the City Clerk shall issue a Notice of Decision describing the City Council's action, with its findings.
2. The City Clerk shall mail the notice to any permit holder, the property owner, the person who requested proceedings under this chapter (if any), and any person who requests such a notification.
3. The City Clerk shall file a copy of the Notice of Decision with the Zoning Officer.

23.414.070 – Statements of Violations

A. **Statement Filed with County Recorder.**

1. If a person does not comply with an order of the Zoning Officer to correct a violation of this chapter within the specified time as provided in Chapter 1.24 (Abatement of Nuisances), the City may file a statement in the Office of the County Recorder that:

- a. Describes the property and nature of the violation; and
- b. Certifies that the property violates this chapter and that the owner has been so notified.

2. The City shall record proof of service with the filed notice and order.

B. Statement Filed after Correction. When a violation is corrected, the Zoning Officer shall file a new statement with the County Recorder certifying that the property is no longer in violation of this chapter.

23.414.080 – Remedies

A. Potential Remedies. If the City makes a nuisance determination, the City may impose any of the following remedies:

1. Enjoin the use in whole or in part.
2. Impose reasonable conditions upon any continued operation of the use, including existing non-conforming uses.
3. Require continued compliance with newly imposed any conditions.
4. Require the permit holder to guarantee compliance with newly imposed conditions.

B. Administrative Penalty. In addition to or as an alternative to any other remedy, the City may impose an administrative penalty of up to \$10,000 jointly and severally on persons responsible for the nuisance and/or the property owner. The City may also impose a condition that the property owners pay the costs of all City services (including but not limited to services for public safety and by the Department of Public Works) necessary to address continuing and unabated public nuisances once the City Council has determined that a public nuisance exists.

C. Remedies Are Cumulative. The procedures and remedies in Subsections (A) and (B) above are cumulative and in addition to any other procedures and remedies to which the City may be entitled by law or equity.

23.414.090 – Recovery of Costs

A. Abatement Proceedings.

1. The City may recover the costs to administer abatement proceedings in accordance with Sections 1.24.140 through 1.24.210 of Municipal Code Chapter 1.24 (Abatement of Nuisances), except as provided in Sub-paragraph (2) below.
2. The hearing provided by Section 1.24.180 shall be held by the City Manager or his/her designee and may be appealed to the City Council within ten days after a

decision is mailed. The Council shall hold a hearing on appeals as specified in Section 1.24.180.

B. Remedies.

1. If the City imposes a remedy authorized in Section 23.414.080 (Remedies), the City may recover costs for time spent administering the remedy.
2. Payment of City costs shall be a condition of continued operation of a use or structure subject to a remedy.
3. Payments submitted under this Subsection B (Remedies) shall be deducted from any payments submitted under Subsection A (Abatement Proceedings) above.

23.414.100 – Private Right of Action

- A. **General.** Any resident of the City may bring a private action in a court of law for injunctive and compensatory relief to prevent or remedy a public nuisance as defined in this chapter.
- B. **Prior Notice Required.** No action may be brought under this section unless and until the prospective plaintiff has given the City and the prospective defendant at least 30 days written notice of the alleged public nuisance and the City has failed to initiate proceedings under this chapter within that period, or after initiation, has failed to diligently prosecute.
- C. **Recovery of Costs.** In any action prosecuted under this section a prevailing plaintiff may recover reasonable attorneys' fees.

DIVISION 5: GLOSSARY

23.502: Glossary

- 23.502.010– Purpose
- 23.502.020– Defined Terms
- 23.502.030– Acronyms

23.502 GLOSSARY

Sections:

- 23.502.010– Purpose
- 23.502.020– Defined Terms
- 23.502.030– Acronyms

23.502.010 – Purpose

This chapter defines terms and phrases used in the Zoning Ordinance that are technical or specialized, or which may not reflect common usage. If any definitions in this chapter conflict with others in the Municipal Code, these definitions control in the Zoning Ordinance. If a word is not defined in the Zoning Ordinance, the Zoning Officer determines the appropriate definition.

23.502.020 – Defined Terms

A. “A” Terms.

1. **Abatement.** City proceedings to terminate, modify, or condition an unlawful use or structure.
2. **Abutting Lot.** See Lot, Abutting.
3. **Accessory Building.** See Building, Accessory.
4. **Accessory Dwelling Unit.** A secondary dwelling unit that is located on a lot which is occupied by one legally established single-family dwelling that conforms to the standards of Chapter 23.306. An accessory dwelling unit must comply with local building, housing, safety and other code requirements and provide the following features independent of the single-family dwelling: 1) exterior access to accessory dwelling unit; 2) living and sleeping quarters; 3) a full kitchen; and 4) a full bathroom. An accessory dwelling Unit also includes the following:
 - a. An efficiency unit, as defined in Section 17958.1 of the Health and Safety Code.
 - b. A manufactured home, as defined in Section 18007 of the Health and Safety Code.
5. **Accessory Structure:** See Structure, Accessory.
6. **Accessory Use:** See Use, Accessory.
7. **Addition.** The creation of any new portion of a building which results in a vertical or horizontal extension of the building, or results in any new gross floor area that was not present in the building before construction of the addition. Includes the

creation of a mezzanine or loft, or a conversion of a previously unused attic or underfloor space to usable floor area.

8. **Addition, Residential.** The creation of any new portion of a main building which results in a vertical or horizontal extension of the building, or results in additional residential gross floor area to an existing main building, as long as such new gross floor area does not exceed 15 percent of the lot area or 600 square feet, whichever is less. For purposes of this definition gross floor area does not include:
 - a. Additions of gross floor area devoted to required off-street parking spaces, creation of mezzanines or lofts within the building's shell;
 - b. Making previously unusable attics into habitable floor area (except where new areas with vertical clearance of 6 feet or greater are created through expansions of the building shell);
 - c. Excavations of earth within the existing building footprint (i.e. expansion of existing basements or new basements), or
 - d. Replacement of existing floor area that was lawfully constructed and is located entirely within the addition's shell.
9. **Addition, Major Residential.**
 - a. A residential addition greater than 15 percent of the lot area or 600 square feet. Floor area from all residential additions since October 31, 1991, with the exception of:
 - i. Additions that are entirely subsumed within previously existing floor area; and
 - ii. The floor area of subsequent stories where the addition does not exceed the district residential addition height limit, shall count towards the calculation of gross floor area for the purposes of this definition.
 - b. Any new floor shall be treated as a new major residential addition for the purpose of permit processing, when the cumulative square footage exceeds 15 percent of the lot area or 600 square feet, whichever is less.
10. **Adult-oriented Businesses.** Any business operated at a fixed location by whatever name, which appeals to prurient interests, sexual titillations, appetites, fantasies or curiosities. This use includes businesses which:
 - a. Predominantly exhibit, offer for sale or engage in the sale or distribution of publications, personal services, films, videotapes, devices, products or materials, which appeal to a prurient interest or sexual appetite of the purchases or user;

- b. Engage in the showing of motion pictures or videotapes in which sexual activity, including, but not limited to, intercourse, sodomy, oral copulation, masturbation, bestiality or any other form of sexual gratification, is the primary and recurring theme;
- c. Engage in the presentation of live adult entertainment in which the actors or performers simulate or engage in sexual activity, including, but not limited to, intercourse, sodomy, oral copulation, masturbation, bestiality or suggestive body movements connoting such acts, with or without another actor, patron or spectator, such showing appealing to a prurient interest or sexual appetite of the spectator;
- d. Engage in massage service, except when made in conjunction with professional services provided by the following persons holding unrevoked licenses or certificates:
 - i.* Chiropractors governed under provisions of California State law;
 - ii.* Medical practitioners practicing under the provisions of the California State Medical Practice Act;
 - iii.* Physical therapists practicing under the provisions of the California Physical Therapy Practice Act;
 - iv.* Nurses practicing under the provisions of the California Nursing Practice Act or the California Vocational Nursing Practice Act;
 - v.* Psychologists practicing under the provisions of the California Psychology Licensing Law;
 - vi.* Osteopaths practicing under the provisions of the California Osteopathic Act;
 - vii.* Persons working under the direct and immediate supervision of any persons certified as set forth in Sections *i-vi* above.
- e. Provide dating or escort services;
- f. Specialize in providing models who pose for photographing, drawing or other representative renditions, which modeling appeals to a prurient interest or sexual appetite;
- g. Engage in encounter, rap or counseling services which appeal to a prurient interest or sexual appetite;
- h. Engage in providing nude, bottomless or topless dance partners;
- i. Use nude, bottomless or topless entertainers, or use nude, bottomless or topless employees to attend to or service tables, bars or patrons or which

- allow nude, bottomless or topless entertainers or employees to be seen by members of the public or patrons of the business;
- j. Engage in providing sauna baths, water baths, showers, steam rooms or steam baths or any other body cleansing or toning arrangement wherein an attendant, clothed or nude, accompanies the customer for the purpose of talking, touching or appealing to the customer's prurient interest or sexual appetite; or
 - k. Engage in the reading of, or providing of tapes or records for listening to, erotic literature which appeals to the prurient interest or sexual fantasies of customers.
11. **Alcoholic Beverage Retail Sales.** The retail sale of beverages containing alcohol for off-site consumption subject to regulation by the State Department of Alcoholic Beverage Control (ABC) as an off-sale establishment. This use includes liquor stores and wine shops and sale of alcoholic beverages for off-site consumption at restaurants.
12. **Alcoholic Beverage Service.** The retail sale of beverages containing alcohol for on-site consumption subject to regulation by the State Department of Alcoholic Beverage Control ABC as an on-sale establishment.
13. **Alley.** A public right-of-way which affords only a secondary means of access for vehicles to any abutting property.
14. **Alteration:** See Structural Alteration.
15. **Alternative Fuel Station.** Any establishment that dispenses alternative fuel as defined by the Energy Policy Act of 2005.
16. **Amusement Device.** Any machine or device which may be operated for use as a game, contest or amusement upon the insertion of a coin, slug, or token in any slot or receptacle attached or connected to such machine, and which does not contain a payoff device for the return of slugs, money, coins, checks, tokens or merchandise.
17. **Amusement Device Arcade.** A type of commercial recreation center which contains six or more amusement devices. An amusement device arcade is a type of commercial recreation center irrespective of whether the amusement devices are the principal commercial activity of the establishment.
18. **Ancillary Use:** See Use, Ancillary.
19. **Application.** A written application for issuance of any permit.
20. **Approval.** Approval of any permit.
21. **Appraiser, Certified.** A person certified by the State of California Office of Real Estate Appraisers to estimate the value of a particular real property.

22. **Art/Craft Studio.** An establishment engaged in the creation of art or crafts that requires artistic skill. Such an establishment may participate in periodic open studios, but otherwise is subject to the applicable zoning district's requirements for incidental sales of goods made on site. Art/craft studios also include rehearsal spaces not designed for public performances. Examples of individuals typically engaged in this work include woodworkers, potters/ceramicists, costume makers, set designers, stained-glass makers, glassblowers, textile artists and weavers, jewelry makers, painters, fine art printmakers, photographers/filmmakers, leather workers, metal workers, musical instrument makers, model makers, papermakers, installation artists, sculptors, video artists, and other makers of art and crafts that the Zoning Officer determines to be consistent with this definition. The use of computers in an activity does not by itself prevent its classification as an art/craft studio. This use excludes architectural and landscape services, industrial or graphic design services, computer systems design services, and other commercial activities normally conducted in an office environment.
23. **Artist Studio.** A detached accessory building, used by residents of a main dwelling unit on the same lot, to create original works of art and crafts products, but not for living quarters or sleeping purposes.
24. **Attic.** The area located between the ceiling of the top story of a building and the building's roof and not usable as habitable or commercial space.
25. **Automatic Teller Machine (ATM).** An unstaffed machine which processes deposits, withdrawals and transfers of funds of customers of a bank, credit union, savings and loan association or other financial service or network.
26. **Automobile Use.** Any commercial establishment which sells, rents, repairs, services, paints and/or conducts bodywork on automobiles, trucks or other motor driven vehicles (excepting motorcycles) on the premises.

B. "B" Terms.

1. Bakery.

- a. An establishment which engages primarily in the sale of breads or other baked goods, whether baked on-site or at another location. A bakery is not be considered a food service establishment if:
- i.* No customer seating or other physical accommodations for on-site dining are provided; and
 - ii.* The breads and baked goods are not packaged for immediate consumption.
- b. Any establishment whose breads and baked goods are predominantly sold at retail from a different location or locations are deemed a wholesale and/or

manufacturing use, subject to the regulations of the district in which it is located.

2. **Balcony.** A horizontal platform extending from the exterior wall of a building, accessible from the building's interior, and not directly accessible from the ground. A balcony is typically not covered by a roof or building overhang or enclosed on more than two sides by walls. However, railings shall not be considered enclosures.
3. **Banks and Financial Services, Retail.** An office, open to the public, offering teller or counter financial services including either cash, checking and/or savings account transactions or some combination of these services. This use includes banks, savings and loans, and credit unions providing these services on site, and excludes non-chartered financial institutions.
4. **Bar/Cocktail Lounge/Tavern.** A business devoted to serving alcoholic beverages for consumption by guests on the premises and in which the serving of food is only incidental to the consumption of such beverages.
5. **Basement.** The lowest usable space of a building, between the floor and the ceiling, for non-habitable use such as, but not limited to, garage or storage use.
6. **Bay Window.** A portion of a building cantilevered so as to project out from a wall and containing windows which cover at least 50 of the projection's surface.
7. **Bed and Breakfast Establishment (B&B).** A single residential property containing no more than a total of three sleeping rooms or dwelling units that are offered for rent at any given time, which is the primary residence of the owner and in which rooms or units are rented out to persons who occupy them for periods not exceeding 14 days in any month.
8. **Bedroom.** Any habitable space in a dwelling unit or habitable accessory structure other than a kitchen or living room that is intended for or capable of being used for sleeping with a door that closes the room off from other common space such as living and kitchen areas that is at least 70 square feet in area, exclusive of closets and other appurtenant space, and meets Building Code standards for egress, light and ventilation. A room identified as a den, library, study, loft, dining room, or other extra room that satisfies this definition will be considered a bedroom for the purposes of applying this requirement. Bathrooms, toilet rooms, closets, halls, storage or utility spaces and similar areas are not considered habitable spaces.
9. **Block.** An area designated on an official map of the City, which is bounded on all sides by the public right-of-way, a railroad right-of-way, private streets or a boundary line of unsubdivided acreage or any combination thereof.
10. **Boarding House.** A building used for residential purposes, other than a hotel, where lodging and meals for five or more persons, who are not living as a

household, are provided for compensation, whether direct or indirect. In determining the number of persons lodging in a boarding house, all residents shall be counted, including those acting as manager, landlord, landlady or building superintendent.

11. **Building.** An enclosed structure having a roof and supported by columns or walls. See Figure 23.502-1 and Figure 23.502-2.
 - a. **Accessory Building.** A detached building containing habitable space, which is smaller in size than the main building on the same lot, and the use of which is incidental to the primary use of the lot.
 - b. **Main Building.** A building which is designed for, or in which is conducted, the primary use of the lot on which it is situated. In any residential district any dwelling, except an accessory dwelling unit, is the main building on the lot.

FIGURE 23.502-1: COMMERCIAL BUILDING

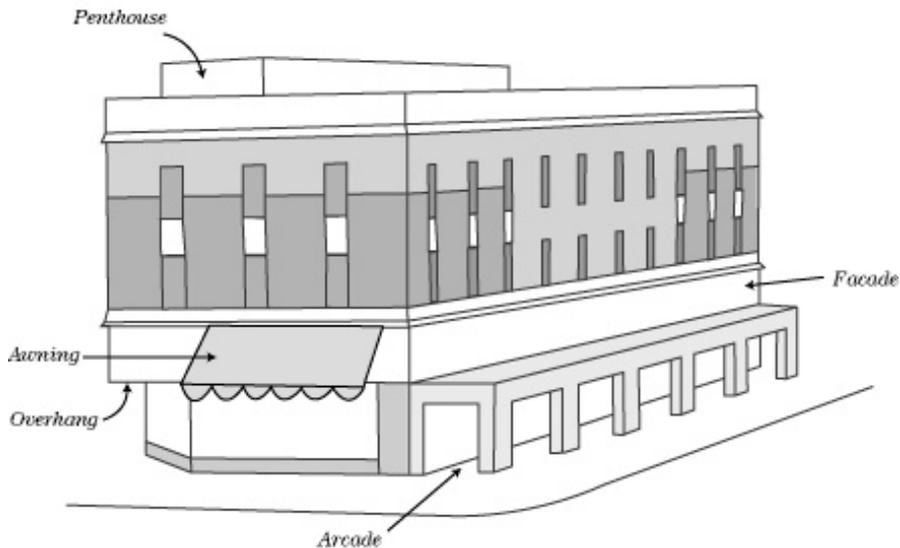
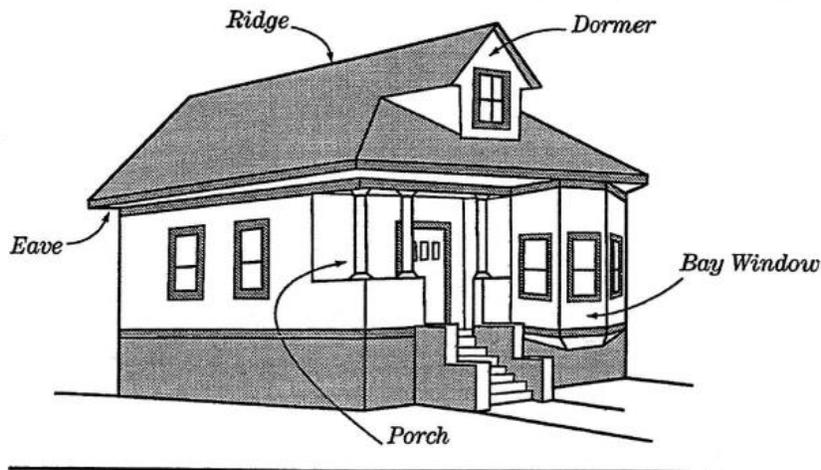

FIGURE 23.502-2: RESIDENTIAL BUILDING



12. **Building Separation.** See 23.106.080 (Building Separation).

13. **Building Site Area.** Same as lot area.

14. **Bus/Cab/Truck/Public Utility Depot.** A facility providing transportation operations for passengers and/or freight. Includes bus terminals and rail stations; facilities for transfer and movement of freight, courier, and postal services by truck or rail; and passenger transportation services, local delivery services, medical transport, and other businesses that rely on fleets of three or more vehicles.

15. **Business Activity.** Any activity subject to Municipal Code Chapter 9.04 and any economic activity which generates receipts but is exempt from Municipal Code Chapter 9.04 by state or federal law.

16. **Business Support Services.** An establishment providing goods and services to other businesses and residents, including maintenance, repair and service, testing, and rental. Permitted services for this use are limited to photocopying, desktop publishing, microfilm recording, slide duplicating, bulk mailing, parcel shipping, parcel labeling, packaging, messenger and delivery/courier, sign painting, lettering, and building maintenance.

C. "C" Terms.

1. **Cafeteria, On-Site.** A food service establishment intended primarily for use by employees or residents working or living at the same location, or for use by patients and/or visitors and restricted from use by the general public.

2. **Cannabis Retailer.** See 12.21.020 (Definitions).

3. **Cannabis Uses.** Includes retail sales, cultivation, manufacturing, testing, and distributing. See Municipal Code Chapters 12.21, and 12.22 for cannabis regulations and Chapter 23.320 for land use regulations.
4. **Carport.** A roofed structure for one or more automobiles which is enclosed by not more than two walls.
5. **Cemetery/Crematory/Mausoleum.** An establishment primarily engaged in operating sites or structures reserved for the interment of human or animal remains, including crematories, mausoleums, burial places, and memorial gardens.
6. **Chair Massage.** Massage given in a public, open setting to a person who is fully clothed and sitting upright on a professional bodywork seat, a stool, or office seat, wheelchair, or other chair-like device.
7. **Change of Use.** Any change in the nature or character of the use of a building or structure.
 - a. A residential change of use includes, but is not limited to, the elimination of any dwelling unit, the reduction in the floor area or habitability of a dwelling unit, or the reduction in the floor area or habitability of bedroom or sleeping quarters in a group living accommodation or residential hotel, when a new use is to replace a previous use. A residential change of use does not include the establishment of a home occupation in compliance with this chapter.
 - b. A commercial change of use includes a change to a different category of commercial or manufacturing use, but does not include changes between uses that are classified in the same category of commercial or manufacturing use.
8. **Child Care Center.** A state-licensed facility providing day care for children. This use includes nursery schools, day nurseries, infant day care centers, and cooperative day care centers, and excludes family day care homes.
9. **Circus or Carnival.** A commercial facility or event for public entertainment, typically held outdoors, with performances, rides, games, exhibitions, and other similar activities for paying customers. May be temporary or permanent.
10. **Club/Lodge.** A building occupied by a group of persons organized for a purpose to pursue common goals, activities or interests, usually characterized by certain membership qualifications, payment of fees or dues, regular meetings and a constitution or by-laws.
11. **City.** The City of Berkeley
12. **Columbaria.** A structure of vaults lined with recesses for cinerary urns or storage of cinerary remains.

13. **Commercial Districts.** The districts listed under the Commercial Districts heading in Table 23.108-1: Zoning Districts.
14. **Commercial Excavation.** The commercial excavation of earth, gravel, minerals, or other building materials, including drilling for, or removal of, oil or natural gas.
15. **Commercial Recreation Center.** Any establishment other than a theater at which recreation facilities are offered or amusement devices provided to the public as a principal commercial activity of such establishment. This use includes bingo parlors, bowling alleys, skating rinks, billiard or pool halls, miniature golf courses. Amusement device arcades are a separately defined types of commercial recreation center with their own permit requirements.
16. **Commercial Use.** The categories of commercial uses of a property include retail products store, personal/household service, food service establishment, entertainment establishment, office, tourist hotel, automobile uses, live/work units, mixed use development, wholesale use, parking lot and any use listed as a sub-category of the above uses; or any other use determined to be a business activity (except home occupations), as these terms are defined in this chapter.
17. **Community Care Facility.** A state-licensed facility for the non-medical care and supervision of children, adolescents, adults or elderly persons. This use includes community care facilities as defined in California Health and Safety Code (H&SC) Section 1500 et seq, residential care facilities for the elderly (H&SC Section 1569 et seq.), facilities for the mentally disordered or otherwise handicapped (California Welfare and Institutions Code Section 5000 et seq.), alcoholism or drug abuse recovery or treatment facilities (H&SC Section 11834.02), supportive housing (California Government Code Section 65582), and other similar facilities. This use excludes medical care institutions, skilled nursing facilities, nursing homes, foster homes, family day care homes, child care facilities, and transitional housing.
18. **Community Center.** A noncommercial facility where the public can meet for social, educational, or recreational activities.
19. **Community and Institutional Use.** The categories of community and institutional uses of a property including, but not limited to, religious assembly uses, clubs/lodges, community centers, hospitals, schools, public uses and utility uses, as these terms are defined in this chapter.
20. **Condition.** A requirement attached to a permit or entitlement, the satisfaction of which is necessary for the validity and effectiveness of the permit or entitlement.
21. **Condominium.** An estate in real property consisting of an undivided interest-in-common in a portion of a lot of real property together with a separate interest in space in a residential, industrial or commercial building on such real property

such as an apartment, office or store. A condominium may include, in addition, a separate interest in other portions of such real property.

22. **Controlled Rental Unit.** Any dwelling unit, live/work unit, bedroom or sleeping quarters portion of a group living accommodation or other unit that is subject to the City's Rent Stabilization Ordinance (Municipal Code Chapter 13.76).
23. **Construction.** The placing of construction materials and their fastening in a permanent manner to the ground or a structure or building for the purpose of creating or altering a structure or building, or excavation of a basement.
24. **Contractors Yard.** A storage facility for any person who contracts to undertake and complete a construction project or a discrete part of a construction project, including all persons defined as contractors and subject to Division 3, Chapter 9 of the State of California Business and Professions Code.
25. **Conversion, Residential.** The physical change of the floor area and/or walls of a building that is used for dwelling unit, group living accommodation or residential hotel room purposes, so as to change the number of dwelling units, sleeping rooms or residential hotel rooms, or reduce the floor area and/or habitable space of any residential living quarters.
26. **Craft.** An occupation, avocation or trade requiring special manual dexterity or artistic skill in the creation of a product.

D. "D" Terms.

1. **Dance/Exercise/Martial Arts/Music Studio.** An establishment in which customers assemble for group exercises, dancing, self-defense training, aerobics, choral or musical instrument instruction, other movement drills for learning, rehearsal or non-audience performances.
2. **Deck.** An unenclosed structure, usually made of wood, built to provide a solid continuous surface for outdoor use and/or access to a door, which is accessible from the ground level, directly or from a connecting stairway and is separated from the ground by an air space.
3. **Demolition.** A building or enclosed structure shall be considered demolished for the purposes of this chapter when, within any continuous 12-month period, such building or enclosed structure is destroyed in whole or in part or is relocated from one lot to another. For purposes of this definition, destroyed in part means when 50 percent or more of the enclosing exterior walls and 50 percent or more of the roof are removed. Removal of facades or portions of facades requires Design Review.
4. **Density Bonus.** See 23.332.020 (Definitions).
5. **Department.** The Planning and Development Department of the City of Berkeley or its successor administrative unit.

6. **Department Store.** A retail store selling several kinds of merchandise, which are usually grouped into separate sections, including but not limited to, apparel, housewares, household hardware, household appliances, household electronics and gifts.
7. **Dormer.** A projection built out from a sloping roof, usually housing a vertical window or ventilating louver. See also 23.304.110 (Dormers).
8. **Dormitory.** A building providing group living accommodations, occupied by individuals not sharing a common household, characterized by separate sleeping rooms without individual kitchen facilities and containing congregate bath and/or dining facilities or rooms.
9. **Drive-in Uses.** A use where a customer is permitted or encouraged, either by the design of physical facilities or by the service and/or packaging procedures offered, to be served while remaining seated within an automobile. This use includes drive-through food service establishments, financial services (banks), and automatic carwashes.
10. **Driveway.** A paved, vehicular accessway connecting an off-street parking space or parking lot with a public or private street.
11. **Drug Paraphernalia.** As defined in California Health and Safety Code Section 11364.5(d).
12. **Drugstore.** A retail establishment where the profession of pharmacy is practiced and/or where licensed prescription drugs and general merchandise are offered for sale. A food products store with a pharmacy is not a drugstore.
13. **Dry Cleaning and Laundry Plants.** A place where clothes are dry cleaned, dyed and/or laundered as part of a commercial business, whether or not such clothes were deposited by a customer at that location, or transported from another location, as part of a service. This use includes all establishments subject to Section 19233 of the State of California Business and Professions Code, regulating Dry Cleaning Plants, but excludes laundromats and cleaners as defined in this chapter.
14. **Duplex.** A building or use of a lot designed for, or occupied exclusively by, two households.
15. **Dwelling Unit.** A building or portion of a building designed for, or occupied exclusively by, persons living as one household.

E. **“E” Terms.**

1. **Electric Vehicle Charging Station.** A facility that supplies electric energy for the recharging of plug-in electric vehicles

2. **Emergency Shelter.** Temporary lodging for homeless persons with minimal supportive services that may be limited to occupancy of six months or less as defined in Health and Safety Code Section 50801(e)).
3. **Enhanced Transit Service.** Any facility that will result in the improved operational performance of bus and/or shuttle service, as well as improvements that will encourage the use of transit and make transit service more compatible with downtown's activities and appearance. Improvements for enhanced transit services include but are not limited to: "complete streets" to enhance pedestrian and bicycle routes to transit; transit signal priority; queue jump lanes and left turn signal phasing; bus shelters and raised bus platforms; bus curb extensions and concrete bus pads; transit pre-pay fare vending machines; bus layover facilities; transit plazas and bus stop amenities; bicycle parking and bicycle rental facilities near transit; and street improvements that mitigate the impact of transit operations on pedestrians and bicyclists.
4. **Entertainment Establishment.** A permanent establishment which includes live performances and/or patron dancing. This use includes cabarets, nightclubs, dance halls, and discotheques.

F. **"F" Terms.**

1. **Facade.** Those portions of a building, including exterior walls, porches, chimneys, balconies, parapets and roof portions, which are visible from a public right-of-way or an adjacent building.
2. **Family.** See Household.
3. **Family Day Care Home.** An establishment providing day care for 14 or fewer children in a dwelling unit as licensed by the California Department of Social Services. A family day care homes must be incidental to a residential use. The day care operator must live in the primary dwelling on the lot.
 - a. **Small Family Day Care Home.** A family day care homes for eight or fewer children, including children who live at the home.
 - b. **Large Family Day Care Home.** A family day care homes for nine to fourteen children, including children who live at the home.
4. **Fence.** A structure made of wood, metal, masonry or other material forming a physical barrier which supports no load other than its own weight, or a hedge, which is designed to delineate, screen or enclose a lot, yard, open space area or other land area.
5. **Firearm/Munitions Businesses.** Any establishment which sells, transfers, leases or offers for sale, transfer or lease any gun, ammunition, munitions, gun powder, bullets, ordnance, or other firearm or firearm parts or supplies.
6. **Floor Area, Gross.** See 23.106.030– Floor Area, Gross.

7. **Floor Area, Leasable.** See 23.106.040– Floor Area, Leasable.
8. **Floor Area Ratio (FAR).** See 23.106.050– Floor Area Ratio.
9. **Food Product Store.** A retail products store selling foods primarily intended to be taken to another location to be prepared and consumed, and the incidental preparation of food or beverages for immediate consumption off the premises.
10. **Food and Beverage for Immediate Consumption.** The sale of food or non-alcoholic beverages for immediate consumption not on the premises.
11. **Food Service Establishments.** An establishment which in whole or in part prepares food or beverages for immediate consumption on or off the premises.
 - a. **Carry Out Food Store:** A store which serves food or non-alcoholic beverages for immediate consumption not on the premises, but usually in the vicinity of the store. This use is usually characterized as an establishment which serves food altered in texture and/or temperature on a customer-demand basis, puts such food in non-sealed packages or edible containers, requires payment for such food before consumption, and provides no seating or other physical accommodations for on- premises dining. Examples of this use include delicatessens and other stores without seating which sell doughnuts, croissants, ice cream, frozen yogurt, cookies, whole pizzas and sandwiches. This use excludes bakeries and food products stores.
 - b. **Quick Service Restaurant:** An establishment which serves food or beverages for immediate consumption either on the premises, or to be taken out for consumption elsewhere. This use is usually characterized as an establishment in which food is cooked on a customer-demand basis, payment is required before consumption, limited or no able service is provided (no waiters), and seating or other physical accommodations for on- premises customer dining is provided. Examples of this use include establishments selling primarily hamburgers or other hot or cold sandwiches, hot dogs, tacos and burritos, pizza slices, fried chicken, or fish and chips.
 - c. **Full-Service Restaurant:** An establishment which serves food or beverages for immediate consumption primarily on the premises, with only a minor portion, if any, of the food being taken out of the establishment. This use is characterized as an establishment in which food is cooked or prepared on the premises on a customer-demand basis, which requires payment after consumption, and provides seating and tables for on-premises customer dining with table service (waiters).
12. **Fraternity House.** A building used for group living accommodations by an organization recognized by the University of California at Berkeley or other institution of higher learning.
13. **Front Wall.** The wall of the building nearest the front lot line.

G. "G" Terms.

1. **Garage, Residential.** A detached accessory structure or portion of a primary building, covered or roofed and enclosed on at least three sides with walls, used for off-street parking by members of the households residing on the premises.
2. **Gasoline/Vehicle Fuel Stations.** An establishment that dispenses gasoline, diesel or other similar fuel into vehicles. Excludes alternative fuel stations and electric vehicle charging stations.
3. **General Plan.** The City of Berkeley General Plan adopted pursuant to Government Code Section 65300 et seq.
4. **Gift/Novelty Shop.** A store selling small manufactured articles usually for personal use or household adornment, including, but not limited to, stores selling primarily T-shirts and/or sweatshirts with imprinted wording or images.
5. **Grade.** The location of ground surface. See also Slope.
 - a. **Existing Grade.** The elevation of the ground at any point on a lot as shown on the required survey submitted in conjunction with an application for a building permit or grading permit. See Figure 23.502-3.
 - b. **Finished Grade.** The lowest point of elevation of the finished surface of the ground between the exterior walls of a building and a point 5 feet distant from the wall, or the lowest point of elevation of the finished surface of the ground between the exterior wall of a building and the property line if it is less than 5 feet distant from the wall. In the case of walls which are parallel to and within 5 feet of a public sidewalk, alley or other public way, the grade shall be the elevation of the sidewalk, alley or public way. See Figure 23.502-3.

FIGURE 23.502-3: GRADE, EXISTING AND FINISHED

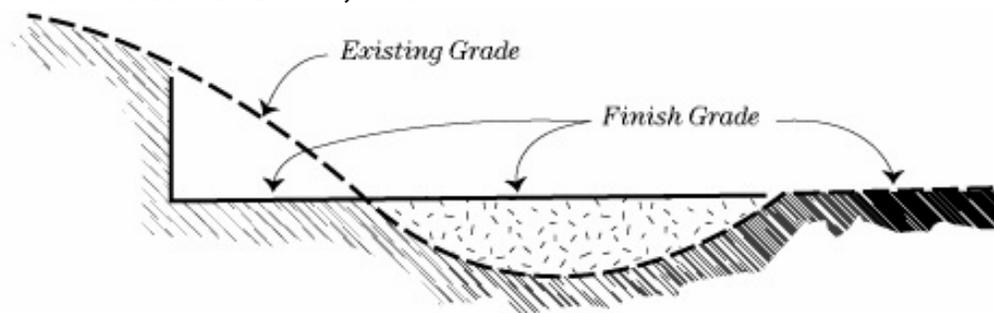

6. **Group Class Instruction.** An establishment that offer specialized programs in personal growth and development. Includes music studios, drama schools, dance academies, art schools, tutoring schools, and instruction in other cultural and academic pursuits.
7. **Group Living Accommodations.** A building or portion of a building designed for or accommodating a residential use by persons not living together as a

household. This use includes dormitories, convents and monasteries, and other types of organizational housing, and excludes hospitals, nursing homes and tourist hotels. Group living accommodations typically provide shared living quarters without separate kitchen or bathroom facilities for each room or unit. Residential hotels and senior congregate housing are separately defined types of group living accommodations each with their own permit requirements

8. **Ground Floor Street Frontage.** The occupied floor space in a structure nearest to the public right-of-way and closest to sidewalk grade.
9. **Gyms and Health Clubs.** An indoor facility where exercise equipment, classes and related activities related to personal health and fitness are available to paying customers. Excludes parks/playgrounds.

H. “H” Terms.

1. **Habitable Space.** A space in a building which is used or designed to be used for living, sleeping, eating or cooking, but not including garages, bathrooms, utility, storage and laundry rooms, halls or closets.
2. **Hedge.** Any line or row of plants, trees or shrubs planted in a continuous line to form a dense thicket or barrier.
3. **Height of Building, Average.** See 23.106.090.A (Average Building Height).
4. **Height of Building, Maximum.** See 23.106.090.B (Maximum Building Height).
5. **Home Occupation.** A business use conducted on property developed with a residential use, which is incidental and secondary to the residential use, does not change the residential character of the residential use, is limited so as not to substantially reduce the residential use of the legally established dwelling, Accessory Dwelling Unit, Accessory Building or Group Living Accommodation room and is operated only by the residents of the subject residence.

There are three classification of Home Occupations. For the purposes of this section, a “customer” is considered a single paying customer, but may include more than one person receiving the services at the same time:

1. Class I Home Occupation - Involves no more than five customer visits per day, with no more than four persons receiving services at a time. This class does not allow shipping of goods directly from the subject residence.
2. Class II Home Occupation - Involves no more than ten customer visits per day, with no more than four persons receiving services at a time and no more than one non-resident engaging in business-related activities on-site. This class does not allow shipping of goods directly from the subject residence.
3. Class III Home Occupation - Involves more than ten customer visits per day, with no more than four persons receiving services at a time and no more

than one non-resident engaging in business-related activities on-site and/or involves shipping of goods directly from the subject residence.

6. **Hospital.** A facility for in-patient medical care licensed under California Administrative Code, Title 17, Section 237 or 238.
 7. **Hot Tub.** A tub or small pool, usually made of wood or fiberglass, in which heated water is maintained for recreational or therapeutic activities, including, but not limited to, jacuzzis, whirlpools and spas.
 8. **Hotel, Residential.** A type of group living accommodations which provides rooms for rent for residential purposes, including single residential occupancy (SRO) rooms.
 9. **Hotel, Tourist.** A building with sleeping rooms used, designed, or intended for occupancy by transient guests for a period not to exceed 14 consecutive days. This use includes inns, bed and breakfasts (B&Bs), and hostels, and excludes building with residential hotel rooms and dwelling units.
 10. **Household.** One or more persons, whether or not related by blood, marriage or adoption, sharing a dwelling unit in a living arrangement usually characterized by sharing living expenses, such as rent or mortgage payments, food costs and utilities, as well as maintaining a single lease or rental agreement for all members of the household and other similar characteristics indicative of a single household.
 11. **Household Income, Gross.** The income of all adult members of the household as determined by the guidelines used by the Berkeley Housing Authority for its administration of the Section 8 Rental Subsidy Program. For purposes of this definition, household is the same as Family in the federal Section 8 Existing Housing Program or its future equivalent. Classification of Households, based on income, shall be based on the following percentages of the Oakland Primary Metropolitan Statistical Area (PMSA) statistical figures for income of the most recent U.S. Census that are available:
 - a. **Low Income Household.** A household whose gross income is greater than 80 percent and less than 100 percent of the median income.
 - b. **Lower Income Household.** A household whose income is no greater than 80 percent and above 50 percent of the median income.
 - c. **Very Low Income Household.** A household whose gross income is 50 percent or less of the median income.
- I. **“I” Terms.**
1. **Incidental Use.** See Use, Incidental.

2. **Inclusionary Unit.** A dwelling unit which is affordable by Households with income below the Oakland PMSA median income; or in the case of Limited Equity Cooperatives, Households with income below 120 percent of the Oakland PMSA median income.
3. **Industrial and Mining Product Sales.** Retail sale of equipment and productions for manufacturing, mining, and other industrial activities.
4. **Insurance Agents, Title Companies, Real Estate Agents, Travel Agents.** A commercial establishment providing insurance, title, real estate and travel services directly to customers.

J. **“J” Terms.**

K. **“K” Terms.**

1. **Kennels and Pet Boarding.** A facility for keeping, boarding, training, breeding or maintaining four or more dogs, cats, or other household pets not owned by the kennel owner or operator on a 24-hour basis. Excludes municipal animal shelters.
2. **Kitchen.** A habitable space used for preparation of food that contains at least a sink, a refrigerator of no less than 10 cubic feet, and either a cooktop and an oven, or a range.

L. **“L” Terms.**

1. **Laboratories.**

- a. **Commercial Physical or Biological.** A facility that provides controlled conditions in which scientific or technological research, experiments, and measurement may be performed.
- b. **Cannabis Testing.** A facility for the testing of the properties of cannabis intended for consumer use.
- c. **Class 1 Organism.** A microbe or biological agent classified as Biosafety Level 1 (BSL-1) by the U.S. Centers for Disease Control and Prevention.
- d. **Class 2 Organism.** A microbe or biological agent classified as Biosafety Level 2 (BSL-2) by the U.S. Centers for Disease Control and Prevention.
- e. **Class 3 Organism.** A microbe or biological agent classified as Biosafety Level 3 (BSL-3) by the U.S. Centers for Disease Control and Prevention.

2. **Land Use.** See “Use.”

3. **Landscaped Area.** An area of ground within the boundaries of a lot which consists of living plant material including, but not limited to, trees, shrubs, ground covers, grass, flowers, gardens and vines.

4. **Large Vehicle Sales and Rental.** Establishments primarily engaged in renting or leasing trucks, truck tractors, buses, semitrailers, and utility trailers.
5. **Lattice Tower.** A support structure, erected on the ground that consists of metal crossed strips or bars to support antennas and related equipment.
6. **Laundromat and Cleaner.** A business which offers self-service laundry and/or dry-cleaning machines and dryers, which are coin, token or otherwise fee operated. This use excludes dry cleaning plants.
7. **Library.** A non-commercial facility where sources of information and similar resources (such as books, recordings, or films) are made available for public use.
8. **Limited Equity Cooperative.** The form of ownership defined in Section 11003.4(a) of the Business and Professions Code or other form of ownership, wherein appreciation of equity of dwelling units is no greater than appreciation permitted by California Health and Safety Code Section 33007.5 for a Limited Equity Cooperative.
9. **Live Entertainment.** Any one or more of any of the following, performed live by one or more persons, whether or not done for compensation and whether or not admission is charged: musical act (including karaoke); theatrical act (including stand-up comedy); play; revue; dance; magic act; disc jockey; or similar activity.
10. **Live/Work.** A built space used or designed to be used both as a workplace and as a residence by one or more persons in conformance with Chapter 23.312 (Live/Work).
11. **Loading Space, Off-street.** A covered or uncovered space for trucks or other delivery vehicles for the loading or unloading of freight, cargo, packages, containers or bundles of goods and/or bulky goods.
12. **Loft.** See mezzanine.
13. **Lot.** A separate legal subdivision of land, as recorded with the County of Alameda Recorder. See Figure 23.502-4: Lot Configuration.
 - a. **Abutting Lot.** A lot having a common property line or separated by a public path or alley, private street or easement to the subject lot.
 - b. **Confronting Lot.** A lot whose front property line is intersected by a line perpendicular to and intersecting the front property line of the subject lot.
 - c. **Corner Lot.** A lot bounded on two or more adjacent sides by street lines, providing that the angle of intersection is less than 135 degrees.
 - d. **Flag Lot.** A lot so shaped that the main portion of the lot area does not have direct street frontage, other than by a connection of a strip of land which is used for access purposes.

- e. **Interior Lot.** A lot bounded on one side by a street line and on all other sides by lot lines between adjacent lots or is bounded by more than one street with an intersection greater than or equal to 135 degrees.
- f. **Key Lot.** Any interior lot which abuts the rear lot line of a corner lot.
- g. **Receiving Lot.** The lot to which a building is relocated from a different lot.
- h. **Source Lot.** The lot from which a building is relocated to a different lot.
- i. **Through Lot.** A lot having frontage on two parallel or approximately parallel streets.

FIGURE 23.502-4: LOT CONFIGURATION

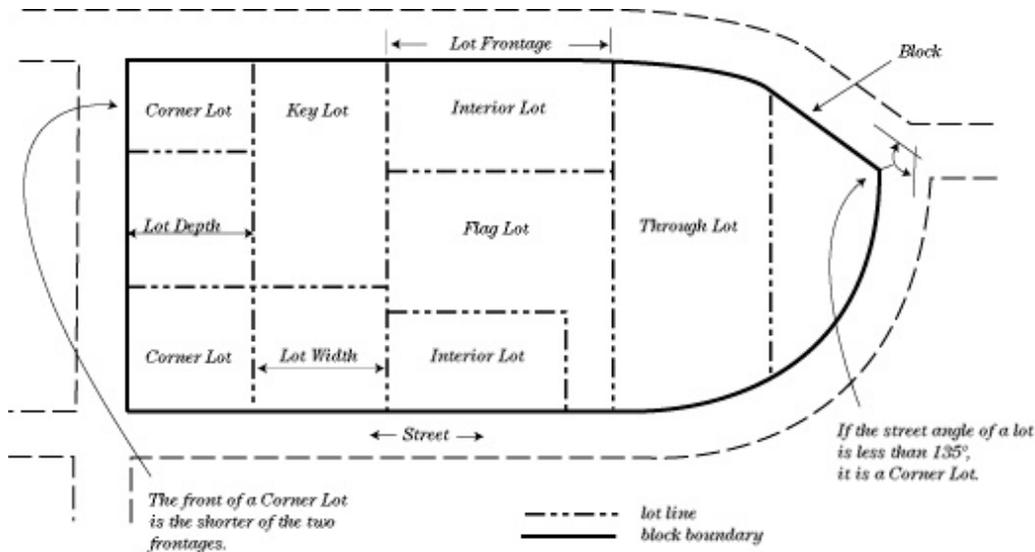

- 14. **Lot Area.** The total horizontal area within a lot's boundary lines.
- 15. **Lot Coverage.** See 23.106.020 (Lot Coverage).
- 16. **Lot Depth.** The average distance from the front lot line to the rear lot line measured in the general direction of the side lines.
- 17. **Lot Frontage.** That dimension of a lot's front lot line abutting on a street.
- 18. **Lot Lines.** The boundaries between a lot and other property or the public right-of-way.
- 19. **Lot Line, Front.** The shorter of the two intersecting lot lines along the rights-of-way of a corner lot shall be deemed to be the front of the lot for purposes of determining the lot frontage and for yard requirements. In the case of a lot having equal frontage, or in the case of an irregularly shaped lot, the Zoning Officer shall determine the front in such a manner as to best promote the orderly development of the immediate area.

20. **Lot Width.** The average distance between the side lot lines measured at right angles to the lot depth.

M. “M” Terms.

1. **Main Building.** See Building, Main.
2. **Maintenance of Building.** Those activities which preserve an existing building including, but not limited to cleaning, painting, refurbishing (but not altering) exterior and interior walls, equipment, facilities and fixtures.
3. **Manufactured Home.** A structure, designed or altered to be used as a dwelling unit, which is transportable in one or more sections and is built on a frame or chassis to which wheels may be attached so as to be transported, including mobile homes meeting the standards of the National Manufactured Housing Construction and Safety Act of 1974. If a manufactured home is mounted on a permanent foundation and connected to all utilities required for a dwelling unit built on the site, it is considered a dwelling unit.
4. **Manufacturing Districts.** The districts listed under the Manufacturing Districts heading in Table 23.108-1: Zoning Districts.
5. **Manufacturing.** A use primarily engaged in the mechanical or the chemical transformation of materials or substances into new products. Manufacturing activities include assembly, baking, brewing, fabrication, milling, processing, refining, smelting and treatment and any other uses determined by the Zoning Officer. Except as otherwise provided in this chapter, manufacturing uses are defined, and distinguished from nonmanufacturing uses, in the North American Industrial Classification Manual (311611 – 339999).
 - a. **Construction Products Manufacturing.** Manufacturing and/or processing asphalt, cement and/or concrete.
 - b. **Light Manufacturing.** Primarily involved in baking, brewing, fabricating, milling, processing and other similar forms of mechanical and chemical treatment. Light manufacturing uses are generally in the following groups in the North American Industrial Classification System (NAICS):

| Use | NAICS Code |
|--|--|
| Apparel and Other Textile Mill Products | 314 – 33636 |
| Electronic and Electric Equipment, except semiconductors | 334412 – 335311, 334413, 333319, 333618, 333992, 335129, 35999 |
| Fabricated Metal Products | 332 – 332999 |
| Food Processing | 311 – 311999 |
| Furniture and Fixtures | 337 – 33792 |
| Industrial Machinery and Equipment | 333 – 333999 |
| Instruments and Related Products | 334511 – 334518 |
| Leather and Leather Products, except leather tanning | 3162 – 316999 |
| Lumber and Wood Products, except logging | 321 – 321999 |
| Miscellaneous Manufacturing | 339 – 339999 |

| Use | NAICS Code |
|--|------------------------------|
| Paper and Allied Products, except paper, pulp and paperboard mills | 3222 – 322299 |
| Perfumes, Cosmetics and Toilet Preparations | 325611 – 32562 |
| Printing and Publishing, except publishing without printing | 323 – 323122 |
| Rubber and Miscellaneous Plastic Products | 326 – 326299 |
| Stone, Clay and Glass Products, except cement | 327 – 327215, 32733 – 327999 |
| Textile Mill Products | 313 – 31332 |
| Transportation Equipment | 336 – 336999 |

- c. **Pesticides, Herbicides and Fertilizers.** Manufacturing and/or processing of substances used for destroying insects or other organisms harmful to cultivated plants or to animals, substances toxic to plants used to destroy unwanted vegetation. and chemicals or natural substance added to soil or land to increase its fertility.
- d. **Petroleum Refining and Products.** The transformation of crude oil into gasoline and other similar petroleum products.
- e. **Pharmaceuticals.** Manufacturing and production of medical drugs.
- f. **Primary Production Manufacturing,** Manufacturing primarily involved in drawing, smelting, refining, rolling and extruding to produce materials such as metals or plastic. Primary production manufacturing uses are generally in the following groups in the North American Industrial Classification System (NAICS):

| Use | NAICS Code |
|---|---|
| Chemicals and allied products, except pharmaceuticals and perfumes, cosmetics and toilet preparations | 325 – 32532, 325413 – 325613, 3259 – 325998 |
| Leather Tanning | 31611 |
| Paper, pulp and paperboard mills | 32211 – 3221 |
| Primary Metal Industries | 331 – 331528 |

- g. **Semiconductors.** The manufacturing of a solid substance that has a conductivity between that of an insulator and that of most metals, either due to the addition of an impurity or because of temperature effects.
6. **Material Recovery Enterprise.** A business that diverts discarded materials from several waste streams including the Transfer Station, drop-off, pick-up and curbside collection. Such facilities must clean, sort, repair and/or process these materials and offer them for reuse and/or recycling through wholesale and/or retail sales, including bulk sales. The retail component of these facilities is limited to the sale of items recovered from the waste stream. No new items may be offered for sale at these facilities. This use excludes flea markets, automobile wrecking establishments, manufacturer’s outlet stores (factory second stores),

consignment shops, second-hand stores, antique stores, and any store which offers only used furniture, clothing and/or household items.

7. **Media Production.** Commercial arts and art-related business services including audio and film recording and editing studios and services, film and video production, titling, video and film libraries, special effects production, motion picture and photograph processing, radio and television broadcast, and similar uses.
8. **Medical Practitioner Office.** Clinics or offices and related laboratories for doctors, dentists, chiropractors, optometrists, mental health practitioners, osteopaths, chiropodists, and similar practitioners of the traditional healing arts, as well as holistic healthcare providers and practitioners of a non-traditional nature. This use includes acupuncturists, herbalists, nutritionists, midwives, reflexologists, iridologists, physical therapists, and bodyworkers, but excludes offices for veterinarians or opticians.
9. **Mezzanine.** An intermediate level of a building interior containing floor area without complete enclosing interior walls or partitions, placed in any story or room and not separated from the floor or level below by a wall.
10. **Microbusiness.** Cannabis use involving more than one State license. See Municipal Code Chapter 12.21 for definition.
 - a. **Retail Nursery Microbusiness.** A microbusiness that is restricted to growing and selling cannabis plants and seeds. See Municipal Code Chapter 12.21 for definition.
 - b. **Retail Storefront Microbusiness.** A microbusiness that is restricted to a Storefront Retailer with limited manufacturing and distribution activities. See Municipal Code Chapter 12.21 for definition and limitations.
11. **Mini-storage.** A storage warehouse characterized by individual separate spaces, which are accessible by customers for storing and retrieval of goods.
12. **Mixed Use.** The use of a lot or building with two or more different land uses including, but not limited to, residential, commercial retail, office or manufacturing, in a single structure or a group of physically integrated structures.
13. **Mixed-Use Residential.** A development project with both residential and non-residential uses which are either 1) located together in a single building; or 2) in separate buildings on a single site of one or more contiguous properties.
14. **Microcell.** A set of antenna nodes networked with each other and connected to a wireless service source, such that a one or more high-power antennas that serve a given area are replaced by a group of lower-power antennas to serve the same geographic area.

15. **Monopole.** A single pole support structure greater than 15 feet in height erected on the ground or on a structure to support antennas and related communications equipment.
16. **Motel, Tourist.** An establishment which provides overnight lodging and parking which contains six or more guest rooms used, designed or intended to be used, let or hired out for occupancy by six or more transient individuals for compensation, whether direct or indirect, and in which the rooms are usually accessible from an outdoor parking lot.
17. **Multi-Family Dwelling.** A building, group of buildings, or portion of a building used or designed as three or more dwelling units.
18. **Municipal Animal Shelter.** A City-owned facility providing services for humane animal care with programs and services focused on maximizing opportunities for animal adoption. Supporting facilities may include medical care (including spay/neuter), kennels, exercise areas and adoption centers.

N. "N" Terms.

1. **New Construction.** Construction of a new main building
2. **Non-Chartered Financial Institutions.** A use, other than State or Federally chartered bank, credit union, mortgage lender, savings and loan association or industrial loan company, that offers deferred deposit transaction services or check cashing services and loans for payment of a percentage fee. This use includes deferred deposit transaction (payday loan) businesses that makes loans upon assignment of wages received, check cashing businesses that charge a percentage fee for cashing a check or negotiable instrument, and motor vehicle title lenders who offer short-term loan secured by the title to motor vehicles. This use excludes non-profit financial institutions or retail sellers engaged primarily in the business of selling consumer goods to retail buyers and that cash checks or issue money orders as a service to its customers that is incidental to its main purpose or business.
3. **Non-conforming Use or Building.** A use or building which is not consistent with a provision or provisions of the Zoning Ordinance, but which was lawfully established or constructed before the effective date of the provision(s) with which it is inconsistent. A use is not considered non-conforming if it is only inconsistent with the Zoning Ordinance with respect to the number of auto or bicycle spaces, their location on site, or screening.
4. **Non-Processed Edibles.** Foods, including fruit, vegetables, nuts, honey, and shell eggs from fowl or poultry, grown or raised in accordance with the Municipal Code, that are whole and intact and have not been processed, but not including cannabis as defined in Chapter 12.26 or meat. Washing, trimming, bundling, and

similar handling of otherwise whole and intact foods shall not be considered processing.

5. **Non-Residential Districts.** Those districts listed under the Commercial Districts, Manufacturing Districts, and Special Districts headings in Table 23.108-1: Zoning Districts.
6. **Non-Residential Use.** Any land use other than a residential use as defined by this chapter.
7. **Nursing Home.** An establishment which provides 24 hour medical, convalescent or chronic care to individuals who, by reason of advanced age, chronic illness or infirmity, are unable to care for themselves, and is licensed as a skilled nursing facility by the California State Department of Health Services. This use includes rest homes and convalescent hospitals and excludes community care facilities, senior congregate housing, and hospitals.

O. **“O” Terms.**

1. **Oakland Primary Metropolitan Statistical Area (PMSA).** A geographic area defined by the U.S. Bureau of the Census, composed of the counties of Alameda and Contra Costa.
2. **Office Use.** A building or portion of a building used for conducting the business or affairs of a profession, business service, non-profit organization, agency, public utility and/or government entity.
3. **Office, Business and Professional.** A building or portion of a building used for conducting the business or affairs of a profession, business service, non-profit organization, agency, public utility and/or government entity. Includes publishing without printing.
4. **One Ownership.** Ownership of property or possession thereof under a contract to purchase by a person or persons, firm, corporation or partnership, individually, jointly, in common or in any other manner whereby such property is under a single or unified control.
5. **Outdoor Cafe Seating.** Tables and/or chairs (including benches) and umbrellas associated with a lawfully operating food service establishment located in an outdoor area on private property.
6. **Owner.** The person or persons, firm, corporation or partnership exercising One Ownership as defined in this chapter.
7. **Owner or Operator (also Provider or Service Provider).** The person, entity or agency primarily responsible for installation and maintenance of the facility, which may or may not be the same person or entity which is the owner of the property on which the facility is located.

P. **“P” Terms.**

1. **Parapet.** A low wall or railing not exceeding 42 inches above the roof and along its perimeter, usually for fire containment and/or architectural purposes.
2. **Parcel.** A term used by the Alameda County Tax Collector to describe a lot, portion of a lot or a group of lots for property tax purposes.
3. **Park/Playground.** Non-commercial facilities that provide open space and/or recreational opportunities to the public.
4. **Parking Area, Accessory.** An area of a lot reserved for use as off-street parking intended to serve a building or use which is the primary or main use of the lot.
5. **Parking Lot/Structure.**
 - a. **Parking Lots.** The exclusive or primary use of a lot for off-street parking spaces in an open paved area.
 - b. **Parking Structures.** The exclusive or primary use of a lot for off-street parking spaces in a structure built specifically for parking purposes.
6. **Parking Space, Off-Street.** An area, covered or uncovered, designed for the storage of an automobile which is paved, accessible by an automobile, and usable for such automobile storage use without permanent obstruction.
7. **Path.** A City-owned right-of-way used or designed for pedestrian access.
8. **Pawn Shops and Auction Houses.** Establishments engaged in the buying or selling of new or secondhand merchandise and offering loans in exchange for personal property.
9. **Penthouse, Mechanical.** A room or enclosed structure, attached to the roof level for the uppermost story, for purposes of sheltering mechanical equipment, water tanks and/or vertical openings for stairwell and elevator shafts. Such a structure is considered a story if it contains usable floor area or habitable space.
10. **Permit, Discretionary.** The following types of permits and approvals:
Administrative Use Permit, Use Permit, Master Use Permit, Modification of Development Standards, Reasonable Accommodations, and Variance.
11. **Permit.** A Use Permit, Administrative Use Permit, or Variance, unless the context specifies otherwise.
12. **Personal/Household Service, General.** A business establishment which provides commercial services directly to customers. This use includes barber/beauty shops, clothing, shoes and/or household items repair shops, dry cleaning and laundry agents, framing/mounting shops, optician shops, photocopy stores, photography studios postal/packaging/po box service shops, and other similar establishments. This use excludes massage.

13. **Pet Store.** Retail sales and services for animals kept as household pets. Includes sales and grooming of animals but not boarding.
14. **Plumbing Shop.** A business offering plumbing supplies and service which has on-site supply storage and service vehicles.
15. **Porch.** A covered projecting platform that extends from the main wall of a building where the covering is supported by columns, walls, or other vertical structural elements.
16. **Primary Dwelling Unit.** A legally established single-family dwelling that is on a lot with an accessory dwelling unit.
17. **Privately-Owned Public Open Space.** Area on a lot that is designed for active or passive recreational use and that is accessible to the general public without a requirement for payment or purchase of goods. Such areas may include mid-block passageways and other amenities intended to improve pedestrian access, and may be outdoors, indoors, or enclosed.
18. **Public Property.** All real property owned, operated or controlled by the City, other than the public right-of-way and any privately- owned area within City's jurisdiction which is not yet, but is designated as a proposed public place on a tentative subdivision map approved by City.
19. **Public Right-Of-Way.** Any public street, public way, public place or rights-of-way, now laid out or dedicated, and the space on, above or below it, and all extensions thereof, and additions thereto, owned, operated and/or controlled by the City or subject to an easement owned by City and any privately-owned area within City's jurisdiction which is not yet, but is designated as a proposed public place on a tentative subdivision map approved by City.
20. **Public Market.** A facility or location where people regularly gather for the sale and purchase of food, beverages, flowers, crafts, and other similar goods. Public markets are open daily, year-round, in a permanent location, with multiple vendors that are owner-operated.
 - a. **Open Air.** A public market conducted outdoors.
 - b. **Enclosed.** A public market conducted indoors.
21. **Public Safety and Emergency Service.** Facilities that provide police and fire protection.
22. **Public Utility Substation/Tanks.** A permanent structure or facility providing a utility service to the general public. Includes generating plants, electric substations, solid waste collection, solid waste treatment and disposal, water or wastewater treatment plants, and similar facilities.

Q. "Q" Terms.

1. **Quorum.** A majority of the appointed members.

R. **“R” Terms.**

1. **Rear Main Building.** A main building situated behind another main building existing or proposed on a parcel located in the R-1A district.
2. **Receiving Lot.** See Lot, Receiving.
3. **Recycled Materials Processing.** A facility that receives and processes recyclable materials. Processing means preparation of material for efficient shipment, or to an end-user’s specifications, by such means as baling, briquetting, compacting, flattening, grinding, crushing, mechanical sorting, shredding, cleaning, and remanufacturing.
4. **Recycling Redemption Center.** A facility, use, or structure for the collection of recyclable goods, including beverage containers and newspapers.
5. **Related Equipment.** All equipment necessary for or related to the provision of personal wireless services. Such equipment may include, but is not limited to, cable, conduit and connectors, equipment pads, equipment shelters, cabinets, buildings and access ladders.
6. **Religious Assembly.** A building or space primarily used for an assembly of persons to conduct worship or other religious ceremonies, including, but not limited to, churches, synagogues, temples, mosques or shrines.
7. **Repair Service, Non-Vehicle.** An establishment that provides repair and maintenance services for household appliance, home electronics, office equipment, furniture and other similar items. Excludes vehicle repair.
8. **Research and Development.** An establishment comprised of laboratory or other non-office space, which is engaged in one or more of the following activities: industrial, biological or scientific research; product design; development and testing; and limited manufacturing necessary for the production of prototypes.
9. **Resident.** A person whose primary residence is in Berkeley.
10. **Residential Care Facility.** See Community Care Facility.
11. **Residential Hotel.** See Hotel, Residential.
12. **Residential Addition.** See Addition, Residential.
13. **Residential Districts.** The districts listed under the Residential Districts heading in Table 23.108-1: Zoning Districts.
14. **Residential Hotel Room.** A room which is:
 - a. Used, designed, or intended to be used for sleeping for a period of 14 consecutive days or more;

- b. Not a complete dwelling unit, as defined in this chapter; and
- c. Not a Tourist Hotel Room, as defined in this chapter.

15. **Residential Use.** Any legal use of a property as a place of residence, including but not limited to dwelling units, group living accommodations, and residential hotels.

16. **Retail, General.** A retail establishment engaged in the sales of personal, consumer, or household items to the customers who will use such items. This use includes antique stores, art galleries, arts and crafts supply stores, bicycle shops, building materials and garden supplies stores, clothing stores, computer stores, cosmetic/personal care items, department stores, drug paraphernalia stores, drug stores, fabric, textile and sewing supply shops, flower and plant stores, food product stores, furniture stores, garden supply stores, nurseries, gift/novelty shops, household hardware and housewares stores, household electronics/electrical stores, jewelry/watch shops, linen shops includes bedding, musical instruments and materials stores, office supply stores, paint stores, photography equipment supply stores, secondhand stores, sporting goods stores, stationery, cards and paper goods stores toy stores and variety stores. This use excludes video rental stores, service of vehicle parts, nurseries, and firearm/munition sales.

17. **Retaining Wall.** A wall designed to contain and resist the lateral displacement of soil and of which such soil is at a higher elevation on one side of the wall.

18. **Review Authority.** The City official or body responsible for approving or denying a permit application or other form of requested approval under the Zoning Ordinance.

19. **Rooming House.** A building used for residential purposes, other than a hotel, where lodging for 5 or more persons, who are not living as a single household, is provided for compensation, whether direct or indirect. In determining the number of persons lodging in a rooming house, all residents shall be counted, including those acting as manager, landlord, landlady or building superintendent. See also Boarding House.

S. "S" Terms.

1. **Satellite Dish.** A device which is designed to receive signals or communications from orbiting satellites.
2. **School.** A building or group of buildings for educational and/or classroom purposes operated by the Berkeley Unified School District (BUSD) and/or other private or public education institutions offering a general course of study at primary, secondary or high school levels which is equivalent to the courses of study at such levels offered by the BUSD. Day nurseries, vocational and trade

schools are considered schools only when incidental to the conduct of a school as defined by this chapter.

3. **School, Vocational.** An educational institution which provides secondary or post-secondary training for technical skills required to complete the tasks of a specific job.
4. **Seasonal Product Sales.** Sales of products for a limited duration of time, usually associated with a seasonal holiday, including but not limited to, sales of Christmas trees and pumpkins.
5. **Service Use.** A business in which no more than fifty percent (50%) of its gross receipts are subject to retail sales taxes.
6. **Services to Buildings and Dwellings.** A business that provides services to customers at a location other than the business location. This use includes carpet/upholstery cleaning services, security services, and janitorial services.
7. **Senior Congregate Housing.** A type of group living accommodations occupied by persons 60 years or older who live in sleeping rooms without kitchen facilities, and which contains congregate bath and/or dining facilities or rooms. This use excludes community care facilities/homes and nursing homes.
8. **Setback.** A distance between a lot line and a building or other site improvement. See also 23.106.070 (Setbacks).
9. **Setback Area.** See 23.106.070.B (Setback Areas).
10. **Setback Line.** A line parallel to a specified lot line which defines a required setback area.
11. **Shed, Garden and/or Tool.** An accessory structure designed to store tools, lawn and garden care or maintenance equipment or materials, and which is not designed to contain any habitable space.
12. **Shelter, Homeless or Women's.** See Transitional Housing.
13. **Short-Term Rental.** See Section 23.314.020 (Definitions).
14. **Sidewalk Cafe Seating.** Tables and/or chairs (including benches) as defined in Municipal Code Section 14.48.150 (Sidewalk cafe seating, benches and planters).
15. **Sign.** Any sign as defined in Municipal Code Section 20.08.220 (Sign).
16. **Single-Family Dwelling.** A building designed for and occupied exclusively by one household.
17. **Single Residential Occupancy (SRO) Room.** A room for residential or sleeping purposes in a residential hotel which is designed for occupancy of one person only.

18. **Skateboard Ramp.** A ramp, platform, course or facility used for skateboard riding and made of wood or other solid material.
19. **Slope.** The steepness of a site, measured as the ratio of the vertical distance to the horizontal distance between the highest and lowest points of the site. See Figure 23.502-5: Grade or Slope.

FIGURE 23.502-5: GRADE OR SLOPE

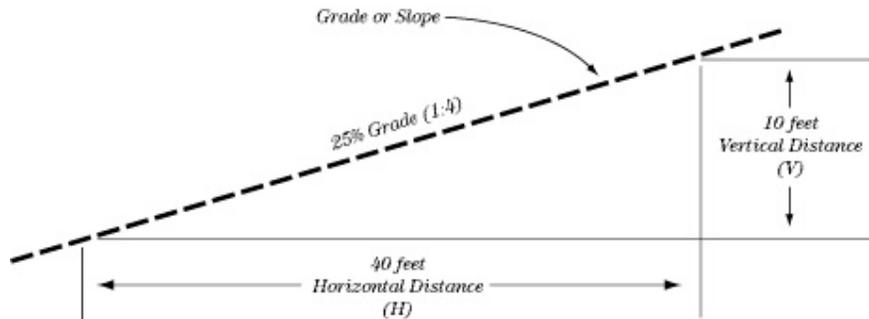

20. **Small Vehicle Sales and Service.** An establishment which sells or leases long-term new, used, or pre-owned motorized vehicles other than passenger automobiles and trucks which are characterized by fewer than four wheels or a minimal frame. Types of vehicles sold or leased by this use include motorcycles, scooters, three-wheel motorcycles, electric carts, electric scooters, and such vehicles designed or refurbished for alternative fuels/power sources (alternative to conventional gasoline).
21. **Smoke Shop.** An establishment engaged primarily in the sale of tobacco and/or tobacco-related products.
22. **Solar Energy Device/Equipment.** Any solar collector or other solar energy device or any structural design feature of a building of which the primary purpose is to provide for the collection, storage or distribution of solar energy for space heating or cooling, water heating or the generation of electricity.
23. **Sorority House.** A building used for group living accommodations by an organization recognized by the UC Berkeley, or other institution of higher learning.
24. **Source Lot.** See Lot, Source.
25. **Story.** See Section 23.106.060 (Story)
26. **Street.** A public or private thoroughfare which provides principal means of access to abutting lots, including but not limited to, avenue, place, way, manor, drive, circle, lane, court, boulevard, highway, road and any other thoroughfare except an alley or a path as defined in this chapter.
27. **Street Line.** The boundary between a lot and an adjacent street.

28. **Structural Alteration.** Any physical change to or removal of the supporting members of a building, foundation or bearing walls, columns, beams or girders or creation or enlargement of a window or door, change of a roofline or roof shape, including creating, enlarging or extending a dormer.
29. **Structural Alteration, Public Safety.** Any structural alteration or physical change to a building that provides greater safety to the public or occupants by strengthening the building against seismic activity, which does not result in new floor area except that created by necessary structural improvements or physical changes as required under Municipal Code Chapter 19.38 and 19.39.
30. **Structure.** Anything constructed or erected, the use of which requires location on the ground or attachment to something having location on the ground. A building is a structure for the purposes of this chapter.
- a. **Accessory Structure.** A detached structure, other than an accessory building, in which non-habitable uses or activities other than the principal use of the property are conducted. Residential accessory structures include, but are not limited to, enclosed structures such as garages, carports, garden or tool sheds, and non-enclosed structures such as, but not limited to, fences, gazebos, ground-mounted satellite dishes, skateboard ramps and wheelchair ramps. Non-residential accessory structures include, but are not limited to, storage buildings, garages, sheds and other outbuildings.
 - b. **Subterranean Structure.** A roofed structure constructed underground, with no building stories aboveground, of which the roof does not exceed 3 feet above the pre-existing grade. Such structures are either separated from a building or connected to a building only by a passageway or hallway with no openings to finished grade except for a doorway.
 - c. **Temporary Structure.** A tent, tent-house, trailer, mobile office, mobile home or other movable structure or other temporary structure whose construction does not require a building permit.
31. **Studio.** See Art/Craft Studio and Dance, Exercise, Martial Arts or Music Studio.
32. **Supportive Housing.** As defined in Health and Safety Code 50675.14(b): Any dwelling unit or a Group Living Accommodation, that is occupied by the target population as defined in subdivision (d) of Section 53260 of the CA Health and Safety Code with no limit on length of stay, that is linked to on- or off-site services that assist the supportive housing residents in retaining the housing, improving their health status, and maximizing their ability to live and, when possible, work in the community.

T. **“T” Terms.**

1. **Temporary Use.** See Use, Temporary.

2. **Tenant Space Reconfiguration.** any physical change to an existing building's walls separating leased spaces so as to change the number of lease spaces for commercial businesses or the square footage of leasable floor area of an existing commercial lease space.
3. **Theater.** Any establishment that has a permanent stage or screen for the presentation of live or recorded entertainment and which contains an audience viewing hall or room, with fixed seats. Theaters may be used for live performances of music, dance, plays, orations, and other stage performances and/or the showing of projected motion pictures and videotapes.
4. **Tire Sales and Service.** An establishment that sells, installs, and provides services for vehicle tires.
5. **Tourist Hotel.** See Hotel, Tourist.
6. **Tourist Hotel Room.** A sleeping room used, designed or intended for occupancy by transient guests for a period not to exceed 14 consecutive days, which is not a residential hotel room or a dwelling unit.
7. **Townhouse.** A dwelling unit in which ownership is in the form of a condominium arrangement which is located in a separate building from any other dwelling unit.
8. **Transitional Housing.** From Health and Safety Code Section 50675.2: Any dwelling unit or a Group Living Accommodation configured as a rental housing development, but operated under program requirements that call for the termination of assistance and recirculation of the assisted units to another eligible program recipient at some predetermined future point in time.
9. **Treehouse.** An accessory structure built within, on or above the branches of any living tree.
10. **Two-Family Dwelling.** A building or use of a lot designed for, or occupied exclusively by, two households.

U. "U" Terms.

1. **Unenclosed Accessory Structure.** An accessory structure that does not have a roof, and/or does not have walls on more than two sides. Unenclosed accessory structures include, but are not limited to, pergolas, trellises, shade structures, arbors, retaining walls, solar energy equipment, ground or pole-mounted satellite dishes, play structures, skateboard ramps, tree houses and windmills.
2. **Urban Agriculture.** The production of horticultural crops for harvest, sale, and/or donation, including community gardens. This use excludes include cannabis cultivation and does not pertain to raising animals.
 - a. **Low-Impact Urban Agriculture.** Urban agriculture that meets the thresholds in Section 23.318.040 (Thresholds).

- b. **High-Impact Urban Agriculture.** Urban agriculture that does not meet one or more of the thresholds in Section 23.318.040 (Thresholds).
3. **Urban Agricultural Products.** Horticultural crops including fruits, vegetables, nuts, flowers, herbs, and any other cultivar, and value-added products made from raw agricultural products grown at the site such as jams, fruit preserves, herb blends, and floral bouquets. Urban agricultural products do not include cannabis products.
 4. **Usable Open Space.** Outdoor space, including natural and landscaped ground areas, pools, patios, decks and balconies designed for active or passive recreational use and which is accessible to the occupants of a building on the same lot.
 5. **Usable Space.** Any portion of a building or structure which is designed to be or can be used as habitable space, which has finished walls (sheetrock or plaster) and/or is heated with any fixed furnace or central heating system, including bathrooms, halls, garages and laundry rooms. Storage areas with over 6 feet of vertical space shall also be considered usable space.
 6. **Use.** The purpose for which land or premises or a building thereon is designed, arranged, or intended or for which it is or may be occupied or maintained.
 7. **Use, Accessory.** A use that is of the same nature as or complementary to the principal use of a lot or a building located on the same lot, and that is not independent of the principal use.
 8. **Use, Ancillary.** A use that is both dependent on and commonly associated with the principal permitted use of a lot and/or building and that does not result in different or greater impacts than the principal use.
 9. **Use, Incidental.** A use of a lot and/or building that is secondary to the principal permitted use, but that by nature could be independent. An incidental use shall not exceed 25 percent of the floor area of the primary use, and if it consists of the commercial sales of a different line of products or services than the primary use, such incidental use may not generate gross receipts in excess of 33 percent of the gross receipts generated by the primary use.
 10. **Use, Primary.** The main purpose for which a site is developed and occupied, including the activities that are conducted on the site a majority of the hours during which activities occur.
 11. **Use, Temporary.** A use of a building, property or land area, that is limited in duration of time, does not permanently change the character or physical facilities of the premises or property and is in keeping with the purposes listed in the district where it is located.

12. **Utility.** An entity which provides water, sewage collection, electricity, natural gas, telephone, cable television or other public service or good to the public.

V. **“V” Terms.**

1. **Vehicle Parts Stores.** An establishment that sells automobile, truck or other vehicle parts or equipment. This use excludes service of vehicle parts.
2. **Vehicle Rentals.** An establishment which rents automobiles, trucks, motorcycles, boats, or other motor-driven vehicles that are stored either indoors or outdoors on its premises.
3. **Vehicle Repair and Service.** An establishment that repairs, services, paints and/or conducts bodywork on automobiles, trucks or other motor-driven vehicles on its premises. Includes restoration of antique and classic cars.
4. **Vehicle Sales.** An establishment which sells, or leases long-term, new, used or previously owned automobiles or trucks; restored vintage, specialty, or antique automobiles or trucks; or automobiles or trucks refurbished for alternative fuels (alternative to conventional gasoline). Ancillary uses and services that are supporting of an vehicle sales use may include the sale and installation of automobile parts, accessories and equipment; repair, maintenance, bodywork and other service of automobiles; loaning of vehicles to service patrons; storage of vehicles outdoors; and automobile washes. This use excludes establishments where more than 50 percent of vehicles sold are previously owned or used (see vehicles sales, used).
5. **Vehicle Sales, Used.** An establishment which sells automobiles and/or trucks of which more than fifty percent at any time are previously owned and/or used.
6. **Vehicle Sharing** (which includes “Car Sharing”). A membership-based service that:
 - a. Provides a mobility service that helps meet City goals for alternative transportation to enhance mobility options, reduce congestion and promote walking, biking and transit;
 - b. Is primarily designed for shorter time and shorter distance trips that can function as an extension of the public transportation network;
 - c. Offers membership to all qualified drivers in the City;
 - d. Does not require a separate written agreement or human intervention to access vehicles each time a member reserves and uses a vehicle;
 - e. Offers members access to a dispersed network of shared automotive vehicles, available 24 hours per day, 7 days a week, at self-service locations where the vehicles are not attended; and

- f. Provides vehicle usage without restriction at hourly and/or per mile rates that are directly proportional to usage and include fuels (gas), insurance, maintenance, and reserved parking when vehicles are not in use.
7. **Vehicle Sharing Pod.** Any location reserved for shared vehicles that:
 - a. Is located in a location approved for off-street parking or municipal parking lot; or
 - b. Is located on street in a site designated by the City for this use; and
 - c. Does not involve more than five shared vehicles per vehicle sharing service provider; and
 - d. Where the shared vehicles must be parked in assigned spaces in conformance with all applicable laws and ordinances.
 8. **Vehicle Wash.** An establishment where the Washing, waxing, or cleaning of automobiles or similar light vehicles are the primary use. Includes self-serve washing facilities.
 9. **Vehicle Wrecking.** An establishment which engages in the on-site dismantling or wrecking of automobiles, trucks, or trailers for the purpose of obtaining parts, metal, or materials for re-use or resale or the storage and keeping of such dismantled parts.
 10. **Veterinary Clinic.** A facility providing veterinarian and/or medical care or treatment for animals. This use includes pet hospitals but excludes kennels or other animal boarding facilities for non-medical care of animals of over 24 hours.
 11. **Video Tape/Disk Rental Stores.** A commercial establishment where the primary business is the rental of video tapes and DVD for the short-term use of customers.
 12. **View Corridor.** A significant view of the Berkeley Hills, San Francisco Bay, Mt. Tamalpais, or a significant landmark such as the Campanile, Golden Gate Bridge, and Alcatraz Island or any other significant vista that substantially enhances the value and enjoyment of real property.

W. "W" Terms.

1. **Warehouse.** A facility for the storage of commercial goods. Includes storage of goods for a contiguous and directly accessible retail space. Excludes mini-storage.
2. **Warehouse-Based Non-Store Retailers.** Retail activity that is based on sales without on-site customer visits. This use includes businesses engaged in catalog sales, internet sales, and phone orders. Goods may be both stored and distributed from site. This use includes delivery-only cannabis retailers located in the Manufacturing (M) district.

3. **Wheelchair Ramp.** A sloping ramp, designed in width and steepness to allow a person in a wheelchair to reach an entrance doorway of a building or a landing at the same level as the doorway.
4. **Wholesale Trade.** The sale of goods to other businesses for resale. Any use defined as conducting Wholesale Trade under Municipal Code Section 9.04.150 is considered a wholesale trade establishment.
5. **Windmill.** A device that converts the kinetic energy of the wind to a usable form of electrical or mechanical energy, usually by rotating blades.

X. **“X” Terms.**

Y. **“Y” Terms.**

1. **Yard.** See Setback Area

Z. **“Z” Terms.**

1. **Zoning Ordinance.** Title 23 of the City of Berkeley Municipal Code.

23.502.030 – Acronyms

- A. Table 23.502-1: Acronyms Used in Zoning Ordinance. shows terms corresponding to acronyms used in the Zoning Ordinance. For zoning district names that correspond to district symbols (e.g., R-1 for Single-Family Residential), see Table 23.108-1: Zoning Districts.

TABLE 23.502-1: ACRONYMS USED IN ZONING ORDINANCE

| ACRONYM | TERM |
|----------------|--|
| ADA | Americans with Disabilities Act |
| AUP | Administrative Use Permit |
| DU | Dwelling Unit |
| FAR | Floor Area Ratio |
| HUD | U.S. Department of Housing and Urban Development |
| LPC | Landmarks Preservation Commission |
| NPO | Neighborhood Preservation Ordinance |
| TSF | Transportation Services Fee |
| UBC | Uniform Building Code |
| UP(PH) | Use Permit, Public Hearing |
| ZAB | Zoning Adjustments Board |
| ZC | Zoning Certificate |

Appendix A
CITY OF BERKELEY BASELINE ZONING ORDINANCE (BZO)
TABLE RELATING NEW ORDINANCE TO OLD ORDINANCE

| New Chapters | Old Chapters |
|---|---|
| Division 1: General Provisions | |
| 23.102: Introductory Provisions | 23A.04: Title, Adoption and Purposes 23A.12: General Regulations 23A.24: Applicability, Emergencies, Interpretation, Severability, Rules of Evidence and Procedure |
| 23.104: Interpreting the Zoning Ordinance | 23A.08: Interpretation and Construction of the Zoning Ordinance |
| 23.106: Rules of Measurement | 23D.04: Lot and Development Standards 23F.04: Definitions |
| 23.108: Zoning Districts and Map | 23A.16: Zoning Maps, Districts and Boundaries |
| Division 2: Zoning Districts | |
| 23.202: Residential Districts | 23D.16: R-1 Single Family Residential District Provisions 23D.20: R-1A Limited Two-Family Residential District Provisions 23D.24: ES-R Environmental Safety-Residential District Provisions 23D.28: R-2 Restricted Two-Family Residential District Provisions 23D.32: R-2A Restricted Multiple-Family Residential District Provisions 23D.36: R-3 Multiple Family Residential District Provisions 23D.40: R-4 Multi-Family Residential District Provisions 23D.44: R-5 High Density Residential District Provisions 23D.48: R-S Residential Southside District Provisions |

| New Chapters | Old Chapters |
|-----------------------------------|--|
| | 23D.52: R-SMU Residential Southside Mixed Use District Provisions |
| 23.204: Commercial Districts | 23E.16: Special Use Standards 23E.18: Temporary Outdoor Uses on Private Property 23E.24: Sidewalk Café Seating 23E.36: C-1 General Commercial District Provisions 23E.40: C-N Neighborhood Commercial District Provisions 23E.44: C-E Elmwood Commercial District Provisions 23E.48: C-NS North Shattuck Commercial District Provisions 23E.52: C-SA South Area Commercial District Provisions 23E.56: C-T Telegraph Avenue Commercial District Provisions 23E.60: C-O Solano Avenue Commercial District Provisions 23E.64: C-W West Berkeley Commercial District Provisions 23E.68: C-DMU Downtown Mixed Use District Provisions 23E.70: C-AC Adeline Corridor Commercial District Provisions |
| 23.206: Manufacturing Districts | 23E.72: M Manufacturing District Provisions 23E.76: MM Mixed Manufacturing District Provisions 23E.80: MU-LI Mixed Use-Light Industrial District Provisions 23E.84: MU-R Mixed Use-Residential District Provisions |
| 23.208: Special Purpose Districts | 23E.88: SP Specific Plan District Provisions 23E.92: U Unclassified District Provisions |
| 23.210: Overlay Zones | 23E.96: H Hillside Overlay District Provisions |

| New Chapters | Old Chapters |
|---|--|
| | 23E.98: Civic Center District Overlay |
| Division 3: Citywide Provisions | |
| 23.302: Supplemental Use Regulations | 23C.06: Bed and Breakfast Establishments in Residential Districts 23C.16: Home Occupations 23C.20: Exemptions 23E.18: Temporary Outdoor Uses on Private Property |
| 23.304: General Development Standards | 23C.04: Lot and Development Standards 23D.08: Accessory Buildings and Structures 23E.04: Lot and Development Standards |
| 23.306: Accessory Dwelling Units | 23D.10: Accessory Dwelling Units |
| 23.308: Emergency Shelters | 23C.10: Emergency Shelter Zoning |
| 23.310: Alcoholic Beverage Sales and Service | |
| 23.312: Live/Work | 23E.20: Live/Work |
| 23.314: Short-Term Rentals | 23C.22: Short-Term Rentals |
| 23.316: Percentage for Public Art on Private Projects | 23C.23: One-Percent for Public Art on Private Projects |
| 23.318: Urban Agriculture | 23C.26: Urban Agriculture |
| 23.320: Cannabis Uses | 23C.25: Cannabis Uses |
| 23.322: Parking and Loading | 23C.19: Off-Street Parking Maximums for Residential Development 23D.12: Off-Street Parking Requirements 23E.28: Off-Street Parking and Transportation Services Fee 23E.32: Loading Space Requirements |
| 23.324: Nonconforming Uses, Structures, and Buildings | 23C.04: Conforming and Non-Conforming Uses, Buildings and Lots |
| 23.326: Demolition and Dwelling Unit Control | 23C.08: Demolition and Dwelling Unit Control |
| 23.328: Inclusionary Housing | 23C.12: Inclusionary Housing Requirements |
| 23.330: Density Bonus | 23C.14: Density Bonus |
| 23.332: Wireless Communication Facilities | 23C.17: Wireless Telecommunication Facilities |
| 23.334: Transportation Demand Management | 23C.18: Transportation Demand Management |

| New Chapters | Old Chapters |
|---|---|
| Division 4: Permits and Administration | |
| 23.402: Administrative Responsibility | 23B.04: Zoning Adjustments Board 23B.08: Design Review Committee 23B.12: Zoning Officer |
| 23.404: Common Permit Requirements | 23B.16: Use of Conflict Resolution or Mediation Service 23B.24: Applications for Permits 23B.56: Conditions Applicable to All Permits 23B.60: Compliance and Revocation |
| 23.406: Specific Permit Requirements | 23B.20: Zoning Conformance Review 23B.28: Administrative Use Permits 23B.32: Use Permits 23B.36: Master Use Permits 23B.40: AUPs for Temporary Uses 23B.44: Variances 23B.48: Modification of Development Standards 23B.52: Reasonable Accommodation 23E.08: Design Review 23E.12: Design Review Process |
| 23.408: Green Pathway | 23B.34: Green Pathway |
| 23.410: Appeals and Certifications | 23.326: Demolition and Dwelling Unit Control |
| 23.412: Zoning Ordinance Amendments | 23A.20: Zoning Ordinance Amendments |
| 23.414: Nuisance Abatement | 23B.64: Abatement of Nuisances 23B.68: Private Right of Action |
| Division 5: Glossary | |
| 23.502: Glossary | 23F.04: Definitions |

Appendix B
CITY OF BERKELEY BASELINE ZONING ORDINANCE (BZO)
TABLE RELATING OLD ORDINANCE TO NEW ORDINANCE

| Old Chapters | New Chapters |
|---|--|
| Sub-Title 23A: Ordinance Applicability | |
| 23A.04: Title, Adoption and Purposes | 23.102: Introductory Provisions |
| 23A.08: Interpretation and Construction of Ordinance | 23.104: Interpretation of the Zoning Ordinance |
| 23A.12: General Regulations | 23.102: Introductory Provisions |
| 23A.16: Zoning Maps, Districts and Boundaries | 23.108: Zoning Districts and Map |
| 23A.20: Zoning Ordinance Amendments | 23.412: Zoning Code Amendments |
| 23A.24: Applicability, Emergencies, Interpretation, Severability, Rules of Evidence and Procedure | 23.102: Introductory Provisions |
| Sub-Title 23B: Ordinance Administration | |
| 23B.04: Zoning Adjustments Board | 23.402: Administrative Responsibility |
| 23B.08: Design Review Committee | |
| 23B.12: Zoning officer | |
| 23B.16: Use of Conflict Resolution or Mediation Service | 23.404: Common Permit Requirements |
| 23B.20: Zoning Conformance Review | 23.406: Specific Permit Requirements |
| 23B.24: Applications for Permits | 23.404: Common Permit Requirements |
| 23B.28: Administrative Use Permits | 23.406: Specific Permit Requirements |
| 23B.32: Use Permits | |
| 23B.34: Green Pathway | 23.408: Green Pathway |
| 23B.36: Master Use Permits | 23.406: Specific Permit Requirements |
| 23B.40: AUPs For Temporary Uses | |
| 23B.44: Variances | |
| 23B.48: Modification of Development Standards | |
| 23B.52: Reasonable Accommodation | |
| 23B.56: Conditions Applicable to All Permits | 23.404: Common Permit Requirements |
| 23B.60: Compliance and Revocation | |
| 23B.64: Abatement of Nuisances | 23.414: Nuisance Abatement |
| 23B.68: Private Right of Action | |
| Sub-Title 23C: General Provisions Applicable in All Districts | |
| 23C.04: Conforming and Non-Conforming Uses, Buildings and Lots | 23.324: Nonconforming Uses and Structures |

| Old Chapters | New Chapters |
|--|---|
| 23C.06: Bed and Breakfast Establishments in Residential Districts | 23.302: Supplemental Use Regulations |
| 23C.08: Demolition and Dwelling Unit Controls | 23.326: Demolition and Dwelling Unit Control |
| 23C.10: Emergency Shelter Zoning | 23.308: Emergency Shelters |
| 23C.12: Inclusionary Housing Requirements | 23.328: Inclusionary Housing |
| 23C.14: Density Bonus | 23.330: Density Bonus |
| 23C.16: Home Occupations | 23.302: Use-Specific Regulations |
| 23C.17: Wireless Telecommunication Facilities | 23.332: Wireless Communication Facilities |
| 23C.18: Transportation Demand Management | 23.334: Transportation Demand Management |
| 23C.19: Off-Street Parking Maximums for Residential Development | 23.322: Parking and Loading |
| 23C.20: Exemptions | 23.302: Supplemental Use Regulations |
| 23C.22: Short-Term Rentals | 23.314: Short-Term Rentals |
| 23C.23: One-Percent for Public Art on Private Projects | 23.316: Percentage for Public Art on Private Projects |
| 23C.24: Accessory Dwelling Units | 23.306: Accessory Dwelling Units |
| 23C.25 Cannabis Uses | 23.320: Cannabis Uses |
| 23C.26: Urban Agriculture | 23.318: Urban Agriculture |
| Sub-Title 23D: Provisions Applicable in All Residential Districts | |
| 23D.04: Lot and Development Standards | Chapter 23.304: General Development Standards |
| 23D.08: Accessory Buildings and Structures | |
| 23D.10: Accessory Dwelling Units | 23.306: Accessory Dwelling Units |
| 23D.12: Off-Street Parking Requirements | 23.322: Parking and Loading |
| 23D.16: R-1 Single Family Residential District Provisions | 23.202: Residential Districts |
| 23D.20: R-1A Limited Two-Family Residential District Provisions | |
| 23D.24: ES-R Environmental Safety-Residential District Provisions | |
| 23D.28: R-2 Restricted Two-Family Residential District Provisions | |
| 23D.32: R-2A Restricted Multiple-Family Residential District Provisions | |
| 23D.36: R-3 Multiple Family Residential District Provisions | |
| 23D.40: R-4 Multi-Family Residential District Provisions | |

| Old Chapters | New Chapters |
|--|---|
| 23D.44: R-5 High Density Residential District Provisions | |
| 23D.48: R-S Residential Southside District Provisions | |
| 23D.52: R-SMU Residential Southside Mixed Use District Provisions | |
| Sub-Title 23E: Provisions Applicable in All Non-Residential Districts | |
| 23E.04: Lot and Development Standards | 23.106: Rules of Measurement 23.304: General Development Standards |
| 23E.08: Design Review | |
| 23E.12: Design Review Process | 23.406: Specific Permit Requirements |
| 23E.16: Special Use Standards | 23.204: Commercial Districts |
| 23E.18 Temporary Outdoor Uses on Private Property | 23.302: Supplemental Use Regulations |
| 23E.20: Live/Work Provisions | 23.312: Live/Work |
| 23E.24: Sidewalk Cafe Seating | 23.204: Commercial Districts |
| 23E.28: Off-Street Parking and Transportation Services Fee | 23.332: Parking and Loading |
| 23E.32: Loading Space Requirements | |
| 23E.36: C-1 General Commercial District Provisions | |
| 23E.40: C-N Neighborhood Commercial District Provisions | |
| 23E.44: C-E Elmwood Commercial District Provisions | |
| 23E.48: C-NS North Shattuck Commercial District Provisions | |
| 23E.52: C-SA South Area Commercial District Provisions | |
| 23E.56: C-T Telegraph Avenue Commercial District Provisions | 23.204: Commercial Districts |
| 23E.60: C-O Solano Avenue Commercial District Provisions | |
| 23E.64: C-W West Berkeley Commercial District Provisions | |
| 23E.68: C-DMU Downtown Mixed Use District Provisions | |
| 23E.70: C-AC Adeline Corridor Commercial District Provisions | |
| 23E.72: M Manufacturing District Provisions | |
| 23E.76: MM Mixed Manufacturing District Provisions | 23.206: Manufacturing Districts |
| 23E.80: MU-LI Mixed Use-Light Industrial District Provisions | |

| Old Chapters | New Chapters |
|--|--|
| 23E.84: MU-R Mixed Use-Residential District Provisions | |
| 23E.88: SP Specific Plan District Provisions | 23.208: Special Purpose Districts |
| 23E.92: U Unclassified District Provisions | |
| 23E.96: H Hillside Overlay District Provisions | 23.210: Overlay Zones |
| 23E.98: Civic Center District Overlay | |
| Sub-Title 23F: Definitions | |
| 23F.04: Definitions | 23.106: Rules of Measurement 23.502: Glossary |

Official Zoning Map

of the
City of Berkeley, California

Adopted by the Berkeley City Council on
March 18, 1999 - Ordinance No. 6478-N.S.

ZONING DISTRICTS

| | |
|--|--|
| R-1 | Single Family Residential |
| R-1A | Limited Two-family Residential |
| R-2 | Restricted Two-family Residential |
| R-2A | Restricted Multiple-family Residential |
| R-3 | Multiple-family Residential |
| R-4 | Multi-family Residential |
| R-5 | High Density Residential |
| ES-R | Environmental Safety-Residential |
| R-S | Residential High Density Subarea |
| R-SMU | Residential Mixed Use Subarea |
| C-DMU | C-DMU Core |
| C-DMU | C-DMU Outer Core |
| C-DMU | C-DMU Corridor |
| C-DMU | C-DMU Buffer |
| C-C | Corridor Commercial |
| C-E | Elmwood Commercial |
| C-N | Neighborhood Commercial |
| C-NS | North Shattuck Commercial |
| C-SA | South Area Commercial |
| C-AC | Adeline Corridor Commercial |
| C-SO | Solano Avenue Commercial |
| C-T | Telegraph Avenue Commercial |
| C-U | University Avenue Commercial |
| C-W | West Berkeley Commercial |
| M | Manufacturing |
| MM | Mixed Manufacturing |
| MULI | Mixed Use-Light Industrial |
| MUR | Mixed Use-Residential |
| SP | Specific Plan |
| U | Unclassified |

OTHER MAP SYMBOLS

| | |
|--|---------------------------|
| | Hillside Overlay Boundary |
| | Arts District Overlay |
| | Southside Plan |
| | Downtown Area Plan |

University Ave Strategic Plan

| | |
|---|------------------|
| | Avenue Mixed Use |
| | UASP Node |

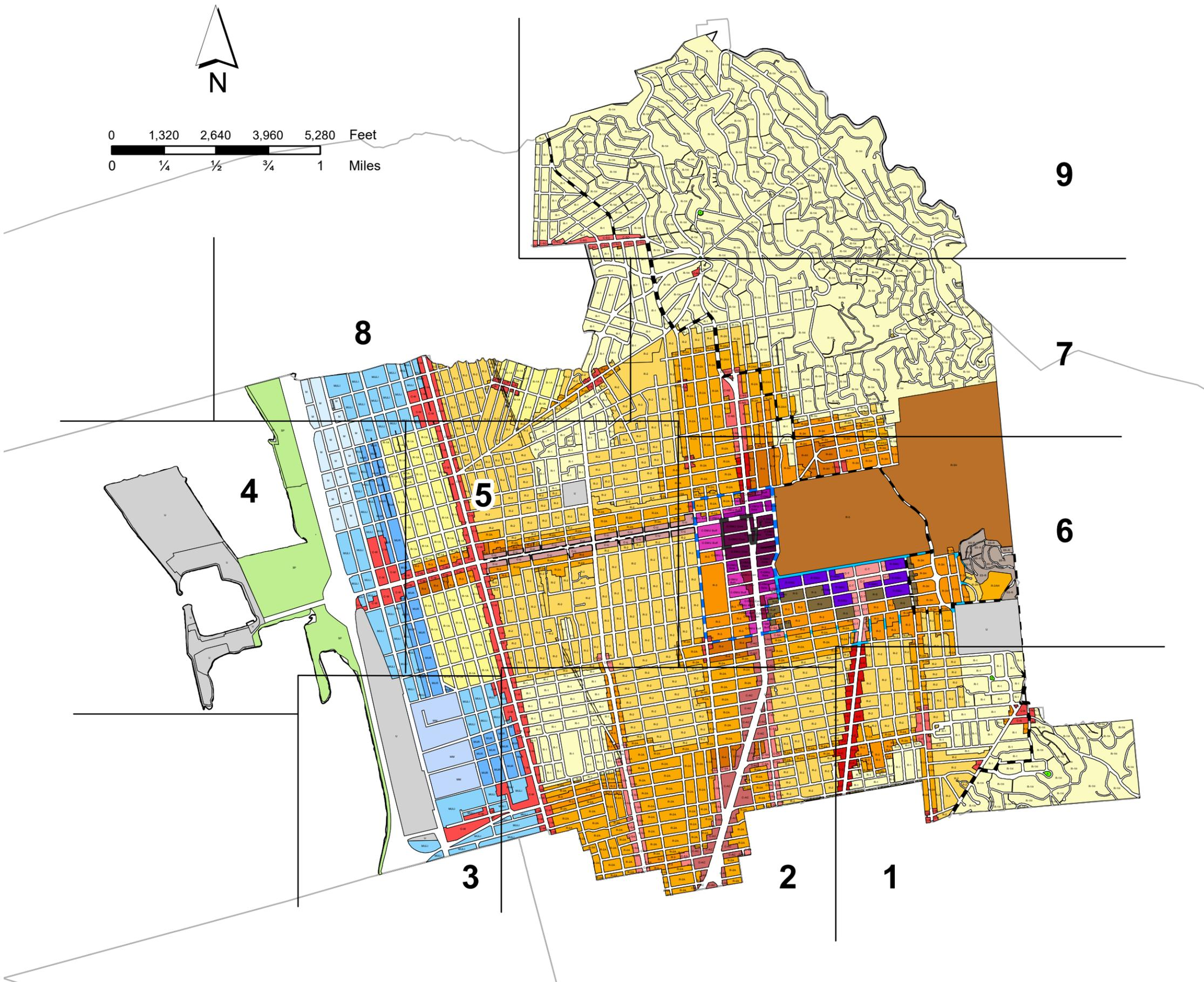

5

6

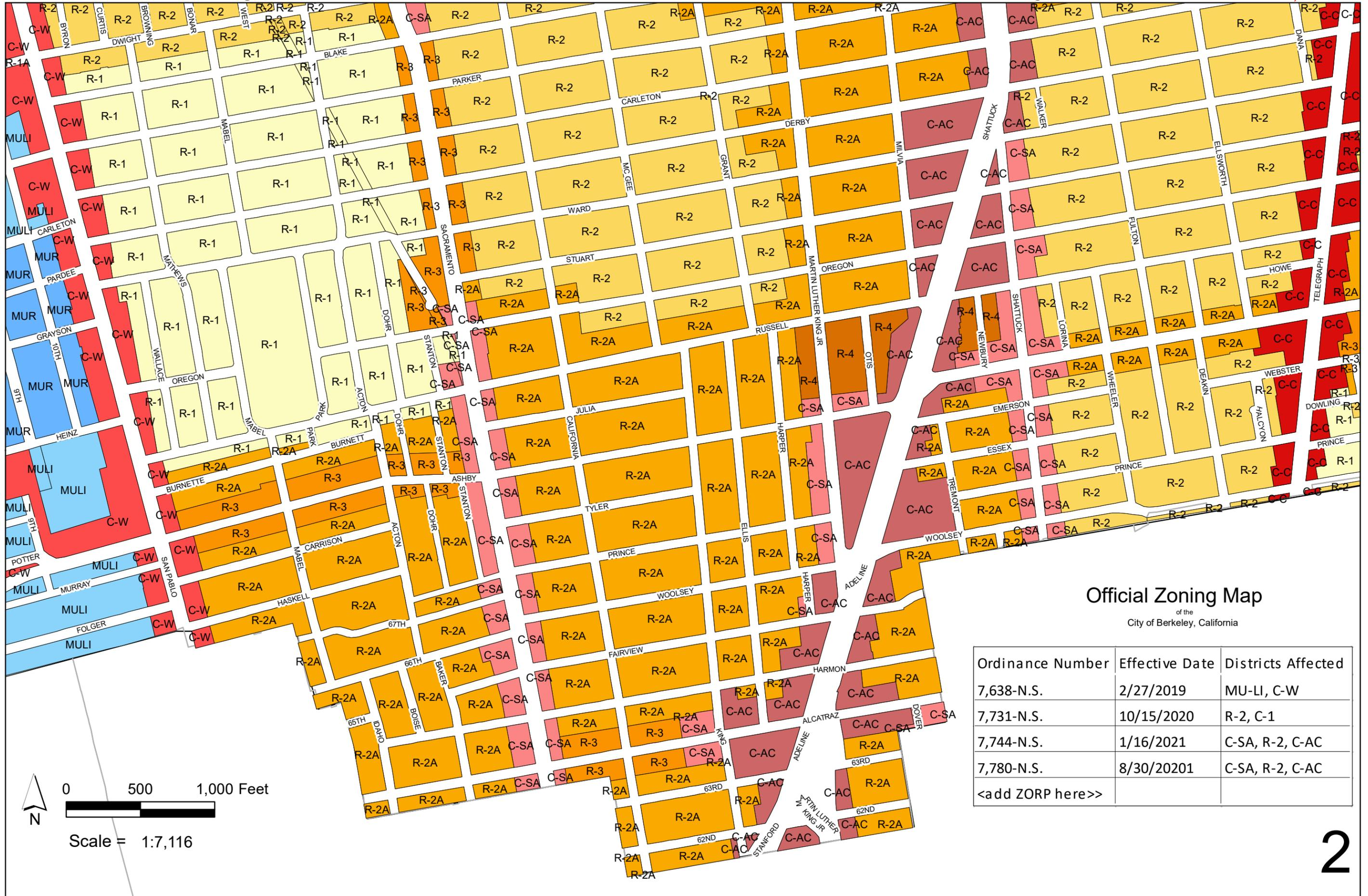

Official Zoning Map

of the
City of Berkeley, California

| Ordinance Number | Effective Date | Districts Affected |
|------------------|----------------|--------------------|
| 7,638-N.S. | 2/27/2019 | MU-LI, C-W |
| 7,731-N.S. | 10/15/2020 | R-2, C-1 |
| 7,744-N.S. | 1/16/2021 | C-SA, R-2, C-AC |
| 7,780-N.S. | 8/30/2021 | C-SA, R-2, C-AC |
| <add ZORP here>> | | |

2

Official Zoning Map

of the
City of Berkeley, California

| Ordinance Number | Effective Date | Districts Affected |
|------------------|----------------|--------------------|
| 6,681-N.S. | 4/18/2002 | R-3, R-2A |
| 6,830-N.S. | 1/6/2005 | C-1 |
| 7,232-N.S. | 5/14/2012 | R-3, C-DMU |
| <add ZORP here> | | |

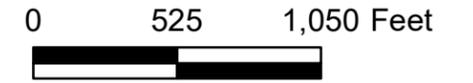

Scale = 1:8,000



8

7

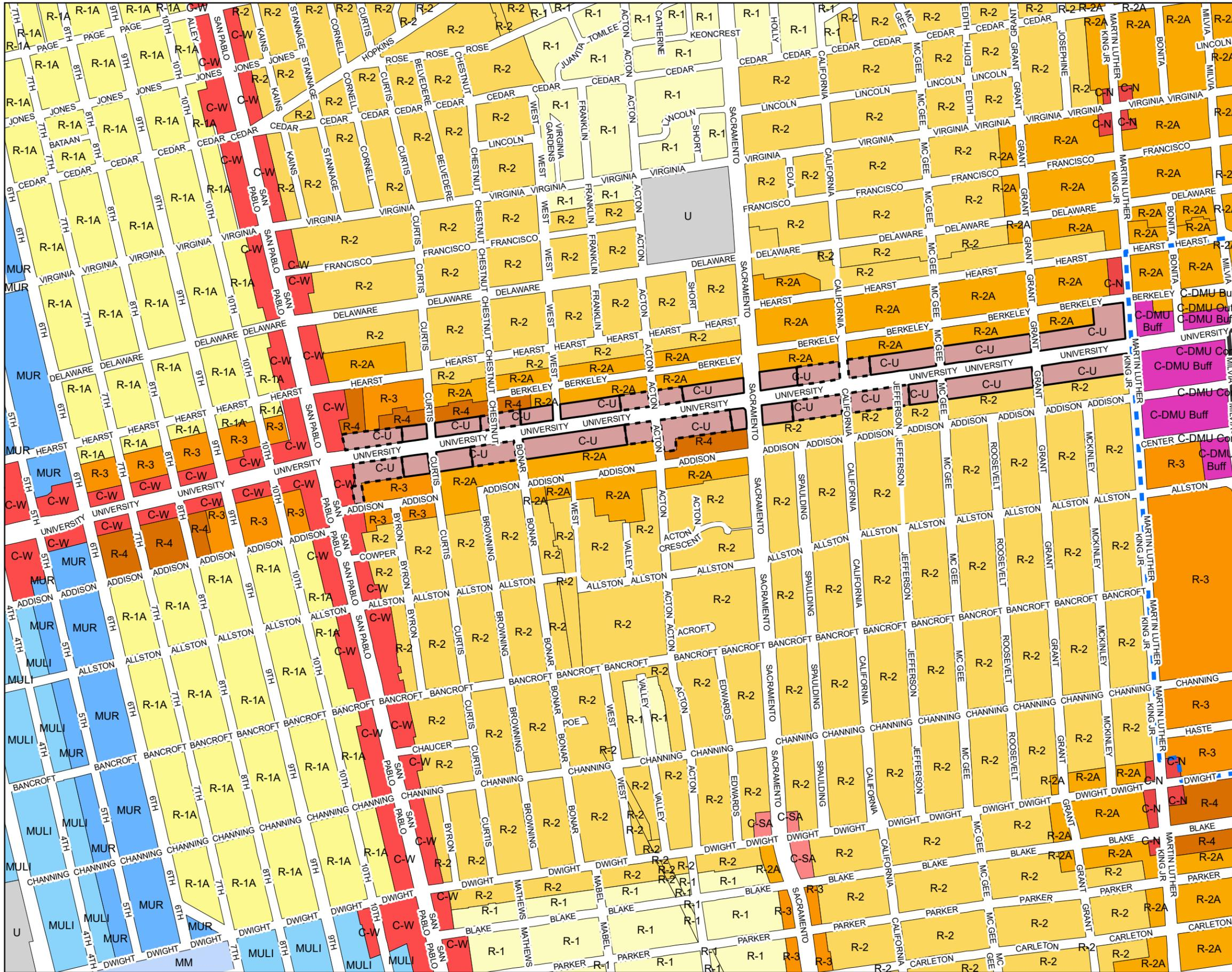

4

3

2

5

Official Zoning Map

of the
City of Berkeley, California

| Ordinance Number | Effective Date | Districts Affected |
|------------------|----------------|--------------------|
| 6,514-N.S. | 12/16/1999 | C-2 |
| 7,211-N.S. | 11/12/2011 | R-S, R-SMU |
| 7,232-N.S. | 5/4/2012 | R-3, C-DMU |
| 7,744-N.S. | 1/16/2021 | C-SA, R-2, C-AC |
| 7,780-N.S. | 8/30/2021 | C-SA, R-2, C-AC |
| <add ZORP here> | | |

0 490 980 Feet

Scale = 1:7,500

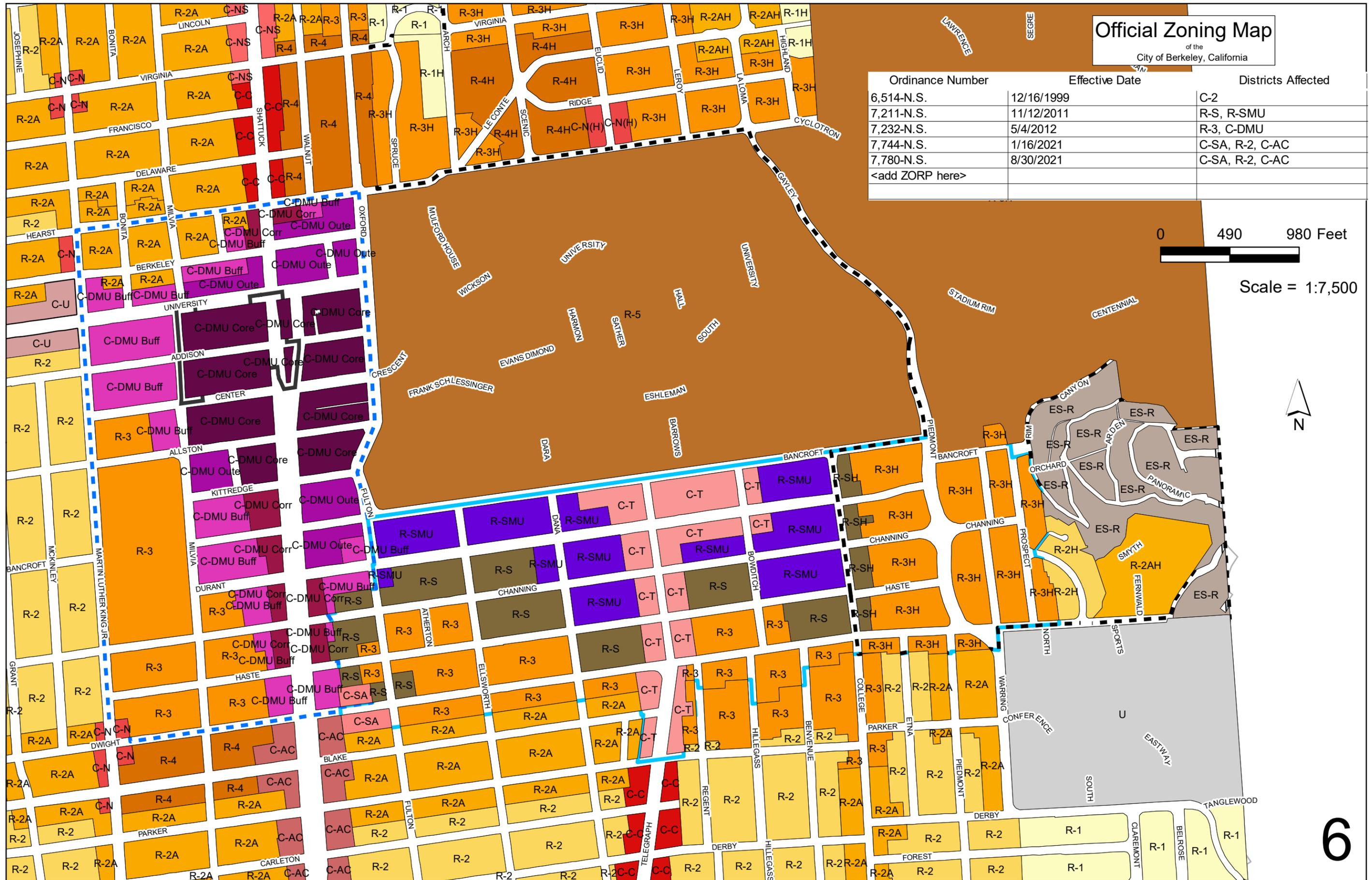

9

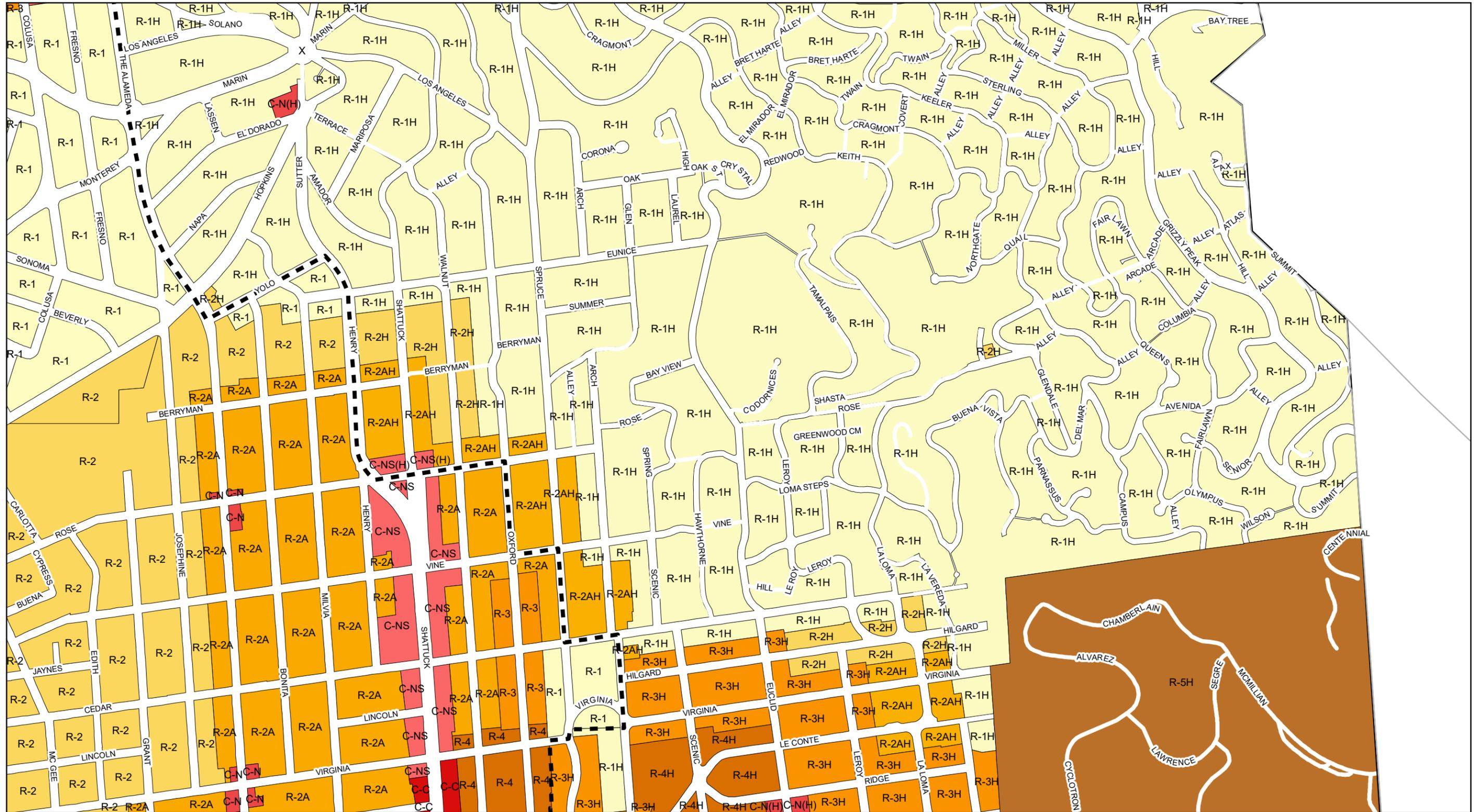

8

5

Official Zoning Map
of the
City of Berkeley, California

| Ordinance Number | Effective Date | Districts Affected |
|------------------|----------------|--------------------|
| <add ZORP here> | | |
| | | |
| | | |
| | | |
| | | |
| | | |
| | | |
| | | |
| | | |
| | | |

6



0 490 980 Feet



Scale = 1:8,000

7